



Accessible Playgrounds, Pools, and Fishing



17

**Professional Development Hours (PDH) or
Continuing Education Hours (CE)
Online PDH or CE course**



UNITED STATES ACCESS BOARD

amusement rides boating facilities fishing piers & platforms golf courses miniature golf sports facilities swimming pools & spa

accessible golf courses



a summary of
accessibility guidelines
for recreation facilities



JUNE 2003

FEDERAL AGENCY COME

DESIGN

FDA, Inc.

Contents

Accessibility Guidelines for Recreation Facilities . . .	3
Introduction.....	3
Golf Courses	7
Accessible Routes	7
Alternative Golf Car Passage	7
Accessible Route Guidelines	8
Course Barriers.....	9
Teeing Grounds	10
Putting Greens.....	11
Weather Shelters.....	11
Driving Ranges	11
Single Rider Adaptive Golf Cars	12
Temporary Facilities	13
For More Information	13

This information has been developed and reviewed in accordance with the Access Board's information quality guidelines (www.access-board.gov/infoquality.htm).

Accessibility Guidelines for Recreation Facilities

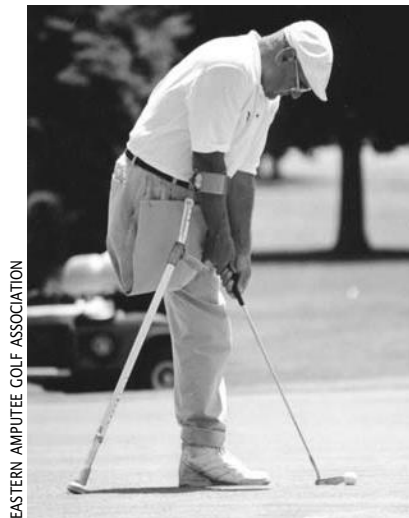

Introduction

The Americans with Disabilities Act (ADA) is a comprehensive civil rights law that prohibits discrimination on the basis of disability. The ADA requires that newly constructed and altered state and local government facilities, places of public accommodation, and commercial facilities be readily accessible to, and usable by, individuals with disabilities. The ADA Accessibility Guidelines (ADAAG) is the standard applied to buildings and facilities. Recreational facilities, including golf courses, are among the facilities required to comply with the ADA.

The Access Board issued accessibility guidelines for newly constructed and altered recreation facilities in 2002. The recreation facility guidelines are a supplement to ADAAG. As a supplement, they must be used in conjunction with ADAAG. References to ADAAG are mentioned throughout this summary. Copies of ADAAG and the recreation facility accessibility guidelines can be obtained through the Board's website at www.access-board.gov or by calling 1-800-872-2253 or 1-800-993-2822 (TTY). Once these guidelines are adopted by the Department of Justice (DOJ), all newly designed, constructed and altered recreation facilities covered by the ADA will be required to comply.

The recreation facility guidelines cover the following facilities and elements:

- Amusement rides
- Boating facilities
- Fishing piers and platforms
- Miniature golf courses
- Golf courses
- Exercise equipment
- Bowling lanes
- Shooting facilities
- Swimming pools, wading pools, and spas

This guide is intended to help designers and operators in using the accessibility guidelines for golf courses. These guidelines establish minimum accessibility requirements for newly designed or newly constructed and altered golf courses. This guide is not a collection of golf course designs. Rather, it provides specifications for elements within a golf course to create a general level of usability for individuals with disabilities. Emphasis is placed on ensuring that individuals with disabilities are generally able to access the golf course and



use a variety of elements. Designers and operators are encouraged to exceed the guidelines where possible to provide increased accessibility and opportunities. Incorporating accessibility into the design of a golf course should begin early in the planning process with careful consideration to the layout of the course, golf car paths, and other circulation paths.

The recreation facility guidelines were developed with significant public participation. In 1993, the Access Board established an advisory committee of 27 members to recommend accessibility guidelines for recreation facilities. The Recreation Access Advisory Committee represented the following groups and associations:

- American Ski Federation
- American Society for Testing and Materials (Public Playground Safety Committee)
- American Society of Landscape Architects
- Beneficial Designs
- City and County of San Francisco, California, Department of Public Works
- Disabled American Veterans
- Environmental Access
- Golf Course Superintendents Association of America
- Hawaii Disability and Communication Access Board
- International Association of Amusement Parks and Attractions
- Katherine McGuinness and Associates



- Lehman, Smith, and Wiseman Associates
- Michigan Department of Natural Resources
- National Council on Independent Living
- National Park Service
- National Recreation and Park Association
- New Jersey Department of Community Affairs
- Outdoor Amusement Business Association
- Paralyzed Veterans of America
- Professional Golfer's Association
- Self Help for Hard of Hearing People
- States Organization for Boating Access
- Universal Studios
- U.S. Army Corps of Engineers
- U.S. Forest Service
- Y.M.C.A. of the U.S.A.
- Walt Disney Imagineering

The public was given an opportunity to comment on the recommended accessibility guidelines, and the Access Board made changes to the recommended guidelines based on the public comments. A notice of proposed rulemaking (NPRM) was published in the Federal Register in July 1999, followed by a five-month public comment period. Further input from the public was sought in July 2000 when the Access Board published a draft final rule soliciting comment. A final rule was published in September 2002.

“Whenever a door is closed to anyone because of a disability, we must work to open it... Whenever any barrier stands between you and the full rights and dignity of citizenship, we must work to remove it, in the name of simple decency and justice.

ACCESSIBLE ROUTE OR GOLF CAR PASSAGE CONNECTING ELEMENTS

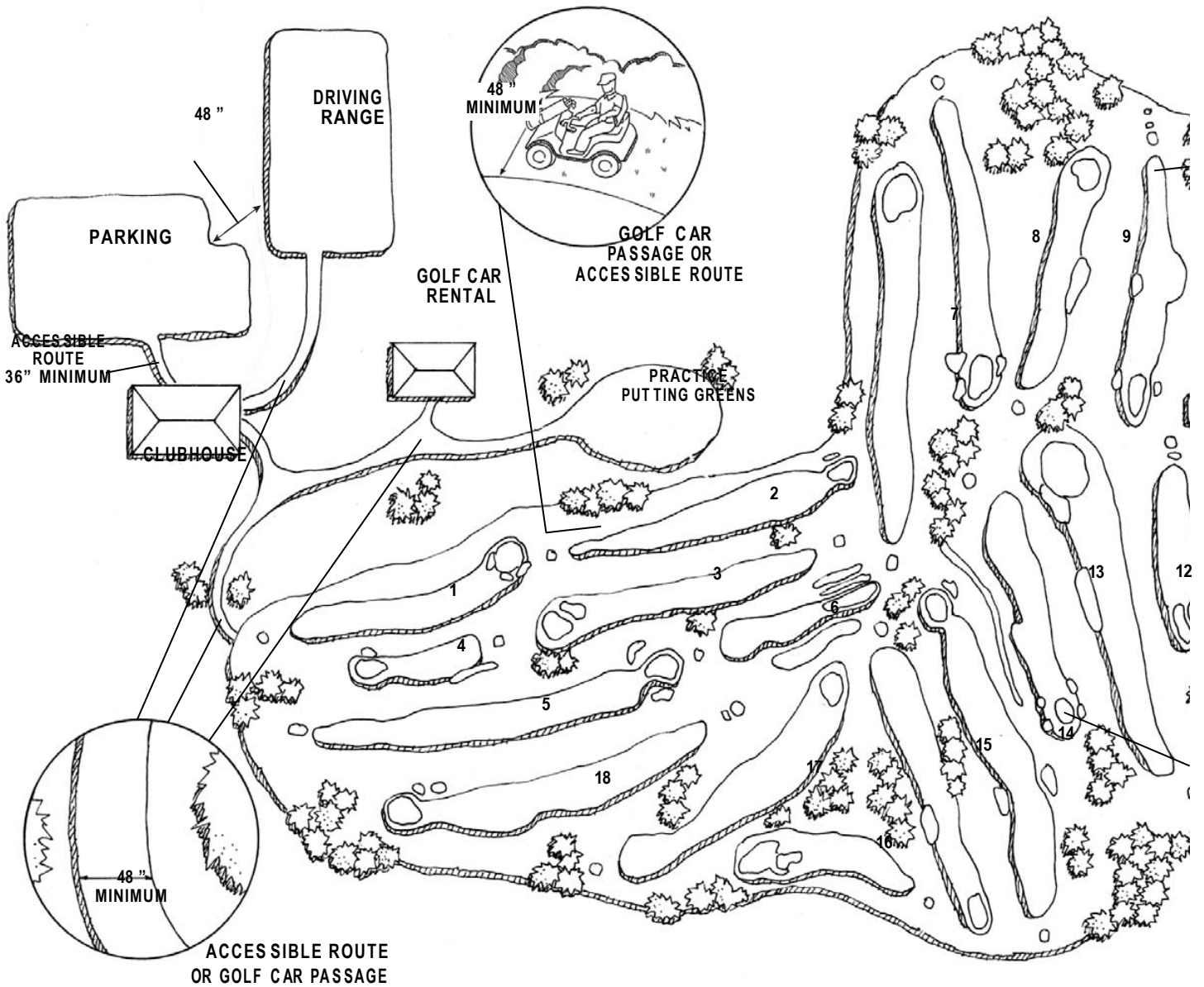

The promise of the ADA...has enabled people with disabilities to enjoy much greater access to a wide range of affordable travel, recreational opportunities and life-enriching services.”

President George W. Bush, New Freedom Initiative, February 1, 2001

Golf Courses

The recreation facility guidelines described in this guide focus on newly designed or newly constructed and altered golf courses and driving ranges. Other provisions contained in ADAAG address elements commonly found at a golf course, such as accessible vehicle parking spaces, exterior accessible routes, and toilet and bathing facilities. ADAAG addresses only the built environment (structures and grounds). The guidelines do not address operational issues. Questions regarding operational issues should be directed to the Department of Justice, 1-800-514-0301 or 1-800-514-0383 (TTY).

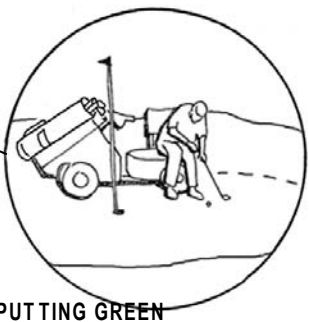
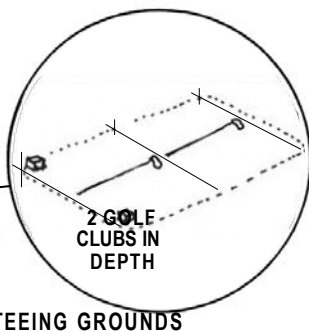

Accessible Routes

Accessible routes are continuous, unobstructed paths connecting all accessible elements and spaces of a building or facility on golf courses. The accessible route must comply with ADAAG provisions for location, width (minimum of 36 inches), passing space, head room, surface, slope (maximum of 1:12 or 8.33%), changes in level, doors, egress, and areas of rescue assistance, unless modified by specific provisions outlined in this guide.

Alternative Golf Car Passage

Providing an accessible route that complies with ADAAG may be impractical throughout a golf course for several reasons.

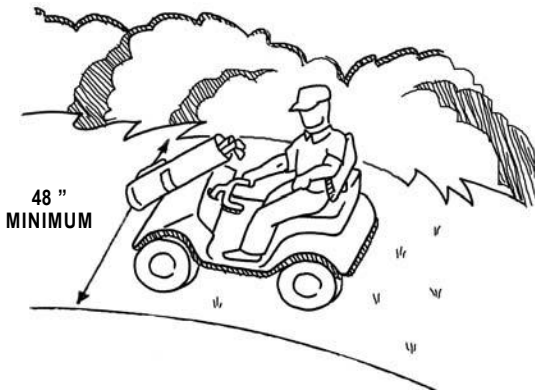

**GOLF CAR PASSAGE
OR ACCESSIBLE ROUTE**

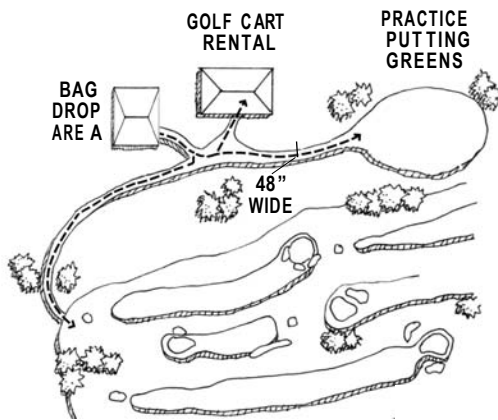

**ACCESSIBLE ROUTE OR
GOLF CAR PASSAGE**

First, the route of play for a golfer is dependent on where the ball lands and is therefore unpredictable. The guidelines assume that on many courses, golfers use a golf car to move throughout the course.

Second, requiring an accessible route throughout a course could alter the slopes within some courses and alter the nature of the sport by eliminating some of the challenge of the game. Therefore, a golf car passage may be substituted for an accessible route *within* the boundary of a golf course. A golf car passage is a continuous passage on which a motorized golf car can operate. While a golf car passage must be usable by golf cars, it does not necessarily need to have a prepared surface and may be part of a golf car path. The golf car passage could be located on areas such as fairways, greens, and teeing surfaces. A golf car passage can be substituted for all or part of the accessible route connecting elements within the boundary of the course and must be a minimum of 48 inches in width.

A golf car passage may also be substituted for an accessible route *outside* the boundary of the golf course when connecting certain elements. This is limited to the golf car rental area, bag drop areas, practice putting greens, accessible practice teeing grounds, course toilet rooms, and course weather shelters.

Accessible Route Guidelines

Where an accessible route is used, the golf course guidelines modify ADAAG's accessible route provisions. They increase

the minimum width for an accessible route from 36 inches to 48 inches. If an accessible route is provided instead of a golf car passage, it must connect accessible elements and spaces located within the boundary of a golf course. The 48-inch minimum width for the accessible route is necessary to ensure passage of a golf car on the accessible route. This is important where the accessible route is used to connect the golf car rental area, bag drop areas, practice putting greens, accessible practice teeing grounds, course toilet rooms, and course weather shelters. These are areas outside the boundary of the golf course, but are areas where an individual using an adapted golf car may travel. Where handrails are provided along an accessible route, the guidelines increase the minimum width of the route to 60 inches to accommodate the passage of a golf car.

Course Barriers

Curbing or other man-made barriers often line golf car paths to restrict golf cars from entering certain portions of the course or to reduce erosion. Where man-made barriers are provided that prevent golf cars from entering a fairway, openings at least 60 inches wide at intervals not exceeding 75 yards must be provided. These dispersed openings will provide access to the course at reasonable intervals, enabling a golfer using a golf car to play the game without extended travel distances and time requirements.

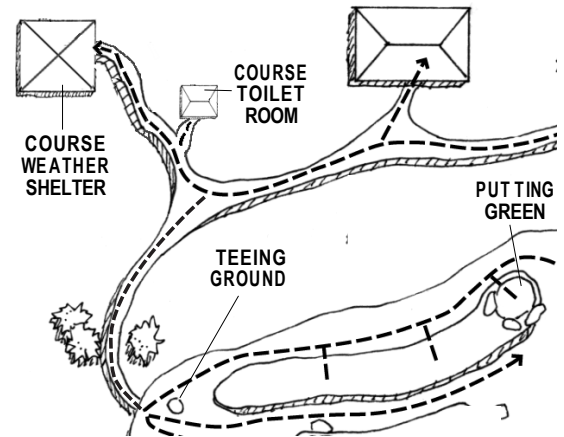

**GOLF CAR PASSAGE
OR ACCESSIBLE ROUTE
ON FAIRWAY**

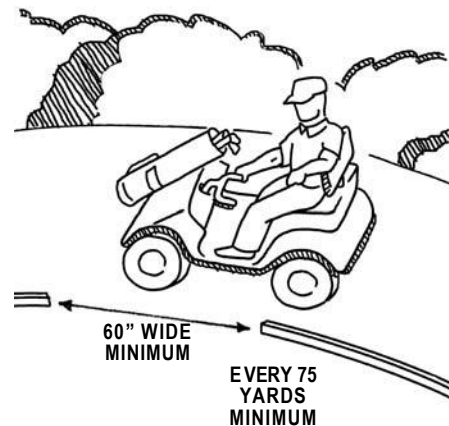

COURSE BARRIERS

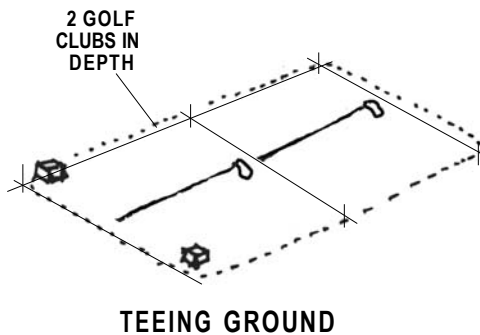

Teeing Grounds

The “teeing ground” is the starting place for a hole of golf. A rectangular area usually two club-lengths in depth, the teeing ground’s borders are defined by the outside limits of two “tee-markers.” The design and construction of new teeing grounds or the alteration of an existing teeing area must allow golf cars to enter and exit within these limits.

- **Forward Teeing Ground**—The forward teeing ground for each hole must be connected by either an accessible route or a golf car passage. Existing courses do not have to provide access to the forward teeing ground in alterations, if terrain makes compliance infeasible.
- **Multiple Teeing Grounds**—If one or two teeing grounds are provided for a hole, only the forward teeing ground must be accessible either by an accessible route or a golf car passage. If three or more teeing grounds are provided for a hole, two teeing grounds must be accessible. This will allow persons with disabilities to play from different tees appropriate to their skill level, while providing flexibility to course operators and designers.

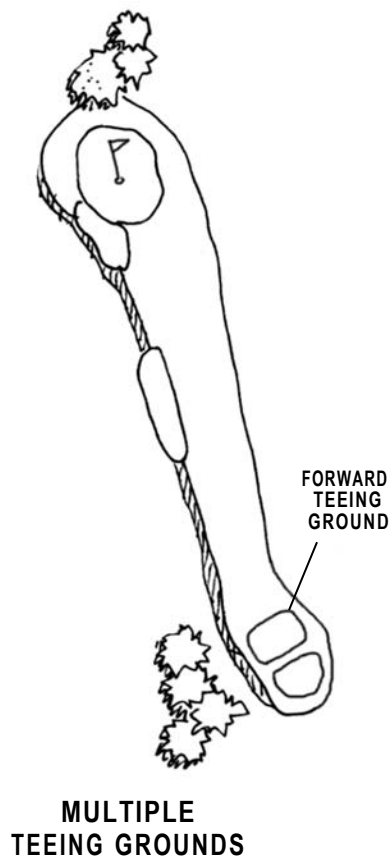

Putting Greens

Each putting green must be designed and constructed so that a golf car can enter and exit the green. The green must be connected by a golf car passage so that a golf car can reach the green.



PUTTING GREEN

Weather Shelters

Course weather shelters must be designed and constructed to allow a golf car to enter and exit, and have a clear floor or ground space of 60 inches by 96 inches minimum. This space will allow a golf car to be driven directly into a weather shelter.



WEATHER SHELTER

Driving Ranges

Both stand-alone driving ranges and driving ranges adjacent to a golf course that provide teeing stations or practice teeing grounds must comply with the following:

- **Accessible Routes**—An accessible route or a golf car passage must connect accessible teeing stations with accessible parking spaces. The accessible route must be a minimum of 48 inches wide. If handrails are provided, the accessible route must be a minimum of 60 inches wide. This will allow a person who plays golf from a golf car to practice driving a golf ball from the same position and stance used when playing the game.

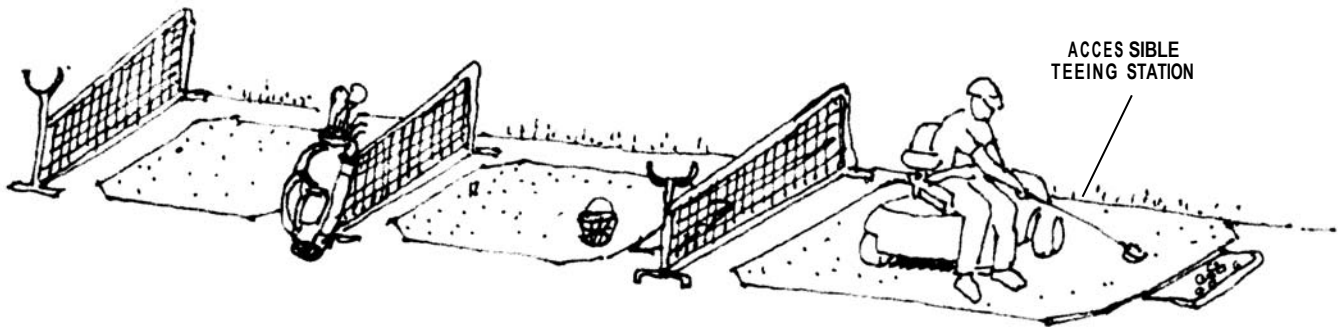

TEEING STATION

- Teeing Stations—If teeing stations or practice teeing grounds are provided, at least five percent, but not less than one, of the practice teeing grounds must be accessible and provide space for a golf car to enter and exit.

Single Rider Adaptive Golf Cars



In recent years, single rider adaptive golf cars have been used to increase access for persons with disabilities on golf courses. Questions have arisen concerning their use. The Access Board develops and maintains accessibility guidelines for the built environment. It is outside the jurisdiction of the Access Board to address operational issues such as the use of these cars. Operators should contact the Department of Justice at 1-800-514-0301 or 1-800-514-0383 (TTY) regarding issues relating to the use and operation of adaptive golf cars.

Temporary Facilities

ADAAG also requires temporary facilities such as bleachers for tournaments, assembly seating areas, portable toilet facilities, concessions, and all other available amenities to provide access. Access to temporary facilities on a golf course may be achieved through either an accessible route or golf car passage. Facilities hosting tournaments or competitions must comply with all the other requirements of the ADA, including the general obligation to provide an equal opportunity to individuals with disabilities to enjoy the services provided.

More Information

You can obtain copies of the recreation facility guidelines, which include golf courses, and further technical assistance from the U.S. Access Board at www.access-board.gov, 1-800-872-2253, or 1-800-993-2822 (TTY).

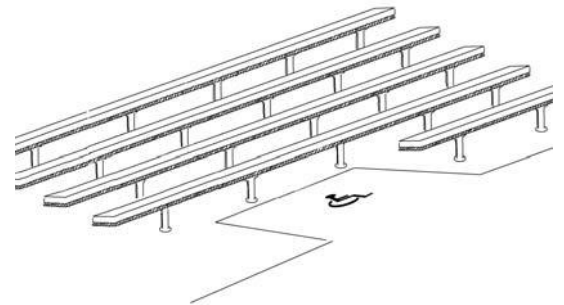

ACCESSIBLE BLEACHERS



United States Access Board

1331 F Street, NW, Suite 1000
Washington, DC 20004-1111

voice (800) 872-2253
tty (800) 993-2822

www.access-board.gov

7 Things Every Playground Owner Should Know About the Accessibility of Their Playground Surfaces

2014

A publication of the U.S. Access Board and the National Center on Accessibility

1 Start with comprehensive planning and site selection.

2 Follow the Accessibility Standards for Play Areas.

3 Review the research findings about accessibility issues for play surfaces.

4 Assess during the planning, installation and maintenance phases.

5 Compare surface options.

6 Recognize that proper installation of play surface systems is key.

7 Commit to ongoing maintenance of accessible playground surfaces as a responsibility of ownership.

Selecting an Accessible Play Surface Is One of the Most Important Decisions

The U.S. Census Bureau's American Community Survey (2011) estimates there to be 2.8 million school-aged children with disabilities in the United States. The Census Bureau (2009) estimates that one in every seven American families is affected by disability. For children with and without disabilities, the community playground can facilitate a positive environment for physical activity and inclusion. Today, lack of physical activity is considered one of the leading factors contributing to poor health among children. The neighborhood playground fulfills a critical role in community wellness, enabling children to play with friends and burn calories at the same time.

When the playground has barriers prohibiting use by a child with a disability, the opportunity for play and physical activity is lost. Inaccessible surfaces can pose barriers for children with disabilities who may use canes, crutches, walkers or wheelchairs from ambulating through the play area. Pushing a wheelchair over loose gravel or sand requires tremendous physical effort. When so much effort is exerted, little to no energy is left for play.

The presence of physical barriers can prevent children with disabilities from accessing all play elements on the playground. Most significantly, inclusive play between children with disabilities and children without disabilities is threatened when the playground does not have accessible equipment and surfaces. Physical barriers also



prohibit adult caregivers with disabilities from engaging with their children and/or responding when a child is in need of assistance.

Recreation professionals and playground owners are confronted with questions of how to install and maintain safe and accessible public playgrounds that are fun; promote inclusion and physical activity; are cost effective and able to withstand a full life cycle of public use.

Choosing play surfaces that are accessible and that can be maintained as accessible surfaces, becomes one of the most important decisions during the playground planning and design phases. The purpose of this guide is to provide practical information that every public playground owner should know about the accessibility of their playground surfaces.

Surfacing the Accessible Playground:

7 Things Every Playground Owner Should Know About the Accessibility of Their Playground Surfaces

From 2008 to 2012, the National Center on Accessibility (NCA) at Indiana University-Bloomington conducted a longitudinal study on the accessibility of playground surfaces. The research study was funded by the U.S. Access Board. The information presented in this publication is based on the research findings and presented as guidance to public playground owners and operators.

Reproduction and dissemination of this publication is encouraged.



U.S. Access Board
1331 F Street NW,
Suite 1000
Washington, DC
20004-1111
(800) 872-2253 Voice
(800) 993-2822 TTY
access-board.gov



National Center on Accessibility
Indiana University - Bloomington
School of Public Health
Department of Recreation, Parks and Tourism Studies
501 N Morton St, Suite 109
Bloomington, IN 47404
(812) 856-4422 Voice
(812) 856-4421 TTY
nca@indiana.edu
ncaonline.org

1 All Successful, Inclusive Playgrounds Start with Comprehensive Planning

An economic assessment conducted during the development of accessibility standards for play areas estimated there to be 5,300 new public playgrounds constructed each year and more than 18,600 existing playgrounds that are renovated. The decision to build a public playground, whether it be in a park, school, mall or childcare setting, is an initial financial commitment of \$60,000 to \$100,000 and upward just for the purchase of equipment and construction (NCA Playground Surface Study, 2013). This cost can be overwhelming. Often times, new playground owners do not realize that owning a playground is not a one-time purchase. It is a commitment to maintain the equipment and surface for as long as it is open to the public. Most public playgrounds are designed to be in place for 10-20 years. At some point, the equipment will need to be serviced to meet revised safety standards and the surface will likely need to be repaired or replaced. A comprehensive planning process is essential to ensure everyone is educated on the safety requirements, the accessibility standards, design considerations, installation and ongoing maintenance needs.

An accessible playground starts with an accessible site plan. The site selection and layout of the accessible route should be considered alongside the selection of the play equipment. The accessible route must be designed as the main pedestrian route and connect all accessible equipment, both points of entry and egress. This means everyone enters and uses the site together.

A site survey may be necessary even on sites deemed “relatively flat.” A site survey, even for sites considered “flat” or without substantial change in elevation, should be conducted to design for a continuous accessible route, with compliant cross slope and adequate site drainage. At playgrounds without site surveys, the National Center on Accessibility research found more instances of non-compliant accessible routes. Most often equipment was moved during construction, deviating from the original plan, to accommodate the use zones. These changes negatively affected the accessible routes.

The site plan should include the layout of equipment and the planned accessible route should be drawn on the site plan connecting entry and egress from each accessible elevated play component and each accessible ground level play component. It is highly recommended that the accessible route be clearly defined on the site plan and construction drawings. If the playground owner decides to go with a surface material, such as loose fill that has a higher degree of surface variability, designation of the accessible route on the site plan will give the installer and maintenance personnel specific guidance on the appropriate location of the accessible route, installation of the surface material, and its ongoing maintenance to meet the accessibility standards.



2 Follow the Accessibility Standards

The 2010 Americans with Disabilities Act (ADA) Standards for Accessible Design apply to state and local governments (Title II) and places of public accommodation (Title III). The Architectural Barriers Act (ABA) Accessibility Standards apply to federal facilities. Both standards require newly constructed playgrounds and those existing playgrounds that are altered to comply with a series of technical provisions for accessible play components and the accessible route connecting these components.

The accessibility standards are minimum standards and do not require the entire play surface area to be accessible. The only required accessible surface area includes the accessible route from the entry of the play area, at least one connection to each accessible play component (points of entry and egress) and any clear space requirements adjacent to accessible play components. Children's play behavior indicates they spontaneously move throughout the play equipment, navigating on their own preferred routes. Designing the entire use zone as a congruent accessible route is recommended as a best practice to accommodate the free play behavior of all children navigating the play space.

Playground owners, designers and maintenance personnel must have a good understanding of the requirements for accessible routes within the play area and comply with the provisions of the accessibility standards. Outside of the play area, an accessible route must connect at the site arrival point, include parking, and the path to the main entrance of the play area. The accessible route must also connect all accessible elements and features of the play area within the site.

Within the play area, the clear width of the ground level accessible routes shall be 60 inches minimum. Two exceptions may be applied: 1) In play areas less than 1000 square feet, the clear width of accessible routes shall be permitted to be 44 inches minimum, if at least one turning space is provided where the restricted accessible route exceeds 30 feet in length; or 2) the clear width of accessible routes shall be permitted to be 36 inches minimum for a distance of 60 inches maximum provided that multiple reduced width segments are separated by segments that are 60 inches wide minimum and 60 inches long minimum.



Where accessible routes serve ground level play components:

- The vertical clearance shall be 80 inches high minimum.
- The running slope not steeper than 1:16 or 6.25%.
- The cross slope shall not be steeper than 1:48 or 2.08%.
- Openings in floor or ground surfaces shall not allow passage of a sphere more than ½ inch diameter.
- Changes in level between ¼ inch high minimum and ½ inch high maximum shall be beveled with a slope not steeper than 1:2.

For a playground surface to be compliant, both safe and accessible, it must meet the above mentioned technical provisions for running slope, cross slope, openings, changes in level, and vertical clearance. Public playgrounds must also meet referenced standards set by the American Society for Testing Materials (ASTM) related to resiliency for falls (ASTM F1292-99/04) and accessibility (ASTM F1951-99) around accessible equipment. Some jurisdictions and municipalities require surface systems to have certificates of compliance with ASTM standards. These certificates are often awarded through laboratory testing of surface samples. The standards require the actual site-installed surface systems to comply with ASTM F1292-99/04 and ASTM F1951-99.

The surface for the accessible route within the play area must meet the technical provisions of the standards as long as it is open for public use. Further, ground surfaces used for the accessible route are required to be inspected and maintained regularly and frequently to ensure continued compliance with ASTM F 1951-99. From the grand opening celebration to the coldest January day when parents bring their children outside to play and get some fresh air; as long as the playground is open for use, it must meet safety and accessibility standards.

Applying the Accessibility Standards to the Plan, Installation, and Maintenance of Ground Level Accessible Routes for Playgrounds

The following questions can be used through the planning process, during construction and as part of routine maintenance.

- ✓ Is the surface for the accessible route, clear ground space and turning space compliant with ASTM F1951-99 Standard Specification for Determination of Accessibility of Surface Systems Under and Around Playground Equipment?
- ✓ Does the playground surface comply with ASTM F1292-99/04 Standard Specification for Impact Attenuation of Surface Systems Under and Around Playground Equipment when ground surfaces are part of the accessible route and also located in the use zones?
- ✓ Is the accessible route part of the main circulation path and is it continuous to each accessible play component?
- ✓ Is the running slope for the ground level accessible route less than 1:16 or 6.25%?
- ✓ Is the maximum cross slope for the ground level accessible route less than 1:48 or 2.08%?
- ✓ Is there a minimum clear width of 60 inches for the ground level accessible route (some exceptions apply)?
- ✓ Are openings in the surface for the ground level accessible route no greater than .50 inch?
- ✓ Are changes in level along the ground level accessible route less than .50 inch beveled?
- ✓ Is the vertical clearance a minimum of 80 inches for the ground level accessible route?
- ✓ Does the clear ground space, 30 x 48 inches minimum, at egress of accessible equipment have a cross slope less than 1:48 or 2.08%?
- ✓ Are the ground surfaces inspected and maintained regularly and frequently to ensure continued compliance with ASTM F1951-99?

For more explanation on the application of the accessibility standards to public playgrounds, see A Summary of Accessibility Guidelines for Play Areas, www.access-board.gov/guidelines-and-standards/recreation-facilities/guides/play-areas.

3 Review the Research Findings to Learn More About Accessibility Issues for Surfaces

From 2008 to 2012, the National Center on Accessibility at Indiana University-Bloomington, conducted a longitudinal study on the accessibility of playground surfaces. The study was funded by the U.S. Access Board. The purpose of this study was to evaluate a variety of playground surfaces, their ability to meet accessibility requirements, their costs upon initial installation and maintenance issues over a 3-5 year period.

The research design for this study of playground surfaces began in 2005 with input from a national advisory committee. During the study, quantitative and qualitative data was collected through on-site inspections for a 3-5 year period. A national advisory committee provided feedback on the categories of surfaces to be evaluated, the criteria to be used for evaluation, the locations within each playground to be evaluated, data collection worksheets and on-site protocol. In addition, advisory committee members helped to expand the network for recruitment in the study and increase national awareness among playground owners.

The sample population for this study depended upon an established, or to be established, congenial relationship with the playground owner and the research team. The data for analysis required the research team to make a number of inquiries to the operation, planning, budgeting and maintenance procedures conducted by the playground owner. Most importantly, if there were any instances where locations on the playground were found to be in non-compliance with the accessibility or safety guidelines, the playground owner was to be informed and then carried the burden of bringing those instances into compliance.

Approximately 35 playground sites were recruited for participation during the evaluation period from October 2008 through May 2011. Data collection concluded in September 2012 so that all playground sites in the study would have a minimum of two years of data. All of the playground sites were located in public parks owned/operated by 16 different municipalities from Indiana, Illinois and Michigan. Sites included either neighborhood playgrounds or those located in regional parks. The 16 participating municipalities operated anywhere from 4 to 53 playgrounds each. None of the playground owners were "first time" owners. All of the owners had a history of managing playgrounds. They considered themselves somewhat knowledgeable of playground surface issues and eager to learn how they could improve upon their playground surface maintenance efforts for costs savings.

The playground surface products considered for this study had to initially meet the requirements of the accessibility standards for: accessible routes; ground surfaces; the ASTM F1292-99/04 Standard Specification for Impact Attenuation of Surface Systems



Under and Around Playground Equipment as determined by the surface manufacturer in laboratory testing; and the ASTM F1951-99 Standard Specification for Determination of Accessibility of Surface Systems Under and Around Playground Equipment as determined by the surface manufacturer in laboratory testing. Information on the surface vendor, specifications, costs and labor for installation was then collected. In turn, the research team contacted each vendor to collect additional information on laboratory certification with ASTM F1951-99 for each surface.

Five categories of surfaces were studied: poured in place rubber (PIP), rubber tiles (TIL), engineered wood fiber (EWF), shredded rubber (SHR) and hybrid (HYB) systems. Nine critical areas were inspected within 12 months of installation and continued to be evaluated at least once a year for the longitudinal study:

- 1) Entry to playground where playground surface starts;
- 2) Accessible route connecting accessible play elements;
- 3) Egress point of slide(s);
- 4) Swings;
- 5) Entry point(s) to composite structure(s)/transfer stations;
- 6) Climber(s);
- 7) Ground level play element(s) such as spring rockers, play tables, interactive panels, etc;
- 8) Sliding poles; and
- 9) Other areas (i.e. water play elements, etc).

A preliminary accessibility assessment of the playground surface was conducted and the surface tested for firmness and stability with the Rotational Penetrometer. At the discretion of the playground owner, the playground surface was also tested for impact attenuation with the TRIAX (surface impact testing device). The playground owner was notified immediately of test results for both the Rotational Penetrometer (firmness/stability) and the TRIAX (impact attenuation) and given opportunity to correct surfaces where deficiencies or non-compliance with standards were noted.

NCA Play Surface Study Findings

The most valuable lesson to be learned from this longitudinal study is that there is no perfect playground surface. Even within 12 months of installation, each type of surface had some type of issue or series of issues that affected the product's performance and contributed to the necessity and frequency of surface maintenance to assure accessibility and safety for use by children on a daily basis. A playground surface with poured-in-place rubber had a use zone found in non-compliance with the ASTM standard for impact attenuation. Playgrounds surfaced with tiles were observed with puncture holes, buckling and separating seams that created openings and changes in level on the accessible route. Inaccessible routes with undulating surface material were identified at playgrounds with engineered wood fiber. Each occurrence and event was weighed and balanced with the product's feature advantages and drawbacks. The information can serve as guidance to both future playground planning and priorities for designing new research. The following are the predominant findings from this study:

1. No single type of surface material/system was found to be the most accessible surface or better than others when comparing its ability to meet the accessibility standards with issues related to installation and maintenance.
2. Within 12 months of installation, playground sites in the sample with the loose fill EWF were found to have the greatest number of deficiencies, such as excessive running slope, cross slope, and change in level, affecting the accessible route to play components.
3. Within 12 months of installation, playground sites in the sample with loose fill EWF were found to have the highest values for firmness and stability, indicating greater work force needed to move across the surface, while playground sites with the unitary surfaces TIL and PIP were found to have the lowest values for firmness and stability— indicating less work force necessary to move across the surface.
4. Deficiencies (excessive running slope, cross slope, change in level, or openings) for PIP, TIL and HYB began to emerge 24-36 months after installation.
5. Occurrences were identified in the sample where the surface material installation did not parallel either the manufacturer's installation instructions or the procedural instructions on the laboratory test sample for ASTM F1951-99.
6. A playground surface with fewer accessibility deficiencies and a lower measurement for firmness and stability did not necessarily meet the safety standards for impact attenuation.
7. Surface cost for material cannot serve as an indicator or predictor of performance.

The full report *A Longitudinal Study of Playground Surfaces to Evaluate Accessibility: Final Report* is available on the National Center on Accessibility web site: ncaonline.org



Comparison of Playground Surfaces Evaluated in NCA



Poured in Place Rubber (PIP)

DESCRIPTION

Wear layer with larger rubber particles and finished with a custom top layer of granular particles. A binding agent is used and the material is poured out on site or "in place" as it gets its name.

COST (Average market cost 2009-2012)(MATERIAL ONLY)

\$6.59 to \$19/sq ft

INSTALLATION

Installer must be specially trained/certified by the manufacturer.

REPAIRS

Repairs must be conducted by trained installer.

COMMON ACCESSIBILITY ISSUES

Cracking or flaking of the top layer can lead to divots and openings greater than 1/2 inch. Top layer deficiencies are often accelerated in high use areas (under swings, slides, teeter-totters). Results in non-compliant routes and clear ground spaces at equipment. May also result in non-compliant cross slope at entry/egress. Surface deficiencies can be traced to improper binding agent ratio, inability for product to properly cure, and deterioration of product over years of exposure to the elements.



Tiles (TIL)

DESCRIPTION

Bonded rubber constructed as 2 ft x 2 ft squares with interlocking sides.

COST (Average market cost 2009-2012)(MATERIAL ONLY)

\$8.96 to \$21/sq ft

INSTALLATION

Can be installed by contractor or park/facility personnel. Learning curve associated with installation.

REPAIRS

Repairs may be completed by contractor or park/facility personnel.

COMMON ACCESSIBILITY ISSUES

Puncture holes and shifting seams can create openings and changes in level along the accessible route and at clear ground space for equipment. Foreign particles can lodge in seams causing separation including lift from adhesive for subsurface. Instances of cracking may occur as the product ages. Settled or washed out subsurface may compromise structural integrity of individual tiles.

Longitudinal Research Study



Engineered Wood Fiber (EWF)

DESCRIPTION

ASTM defines EWF as processed wood ground to a fibrous consistency, randomly sized, approximately 10 times longer than wide with a maximum length of 2 inches. Free of hazardous substances. Not to be confused with wood chips.

COST (Average market cost 2009-2012)(MATERIAL ONLY)

\$ 0.74 to \$2.50/sq ft

INSTALLATION

Can be installed by contractor or park/facility personnel.

REPAIRS

Repairs may be completed by contractor or park/facility personnel.

COMMON ACCESSIBILITY ISSUES

Improper installation and/or maintenance can result in undulation across the horizon of the surface affecting running slope, cross slope and change in level. Product material should be installed in layers and compacted in order to achieve an accessible route and level clear ground space at equipment. Surface material is likely to displace at heavy use areas with motion, such as at swings, slides, sliding poles, climbers, spinners and teeter totters. Displaced material should be raked level and compacted before additional fill is added.



Hybrid Surface Systems (HYB)

DESCRIPTION

Multi-layer system where the base layer may consist of either contained or loose particles like shredded rubber or carpet pad. The top layers may be outdoor carpeting, artificial turf, or rubber top mat.

COST (Average market cost 2009-2012)(MATERIAL ONLY)

\$7.50 to \$12.65/sq ft

INSTALLATION

Installer must be specially trained/certified by the manufacturer.

REPAIRS

Usually repairs must be conducted by the installer. In some cases, park/facility personnel may be trained to make smaller repairs.

COMMON ACCESSIBILITY ISSUES

Seams may separate or detach from the border creating changes in level and openings affecting the accessible route. Shifting of loose fill in the base layer may affect running and cross slopes. The artificial turf top layer may experience build-up of static electricity requiring application of anti-static solution.

4 Assess During the Planning, Installation and Maintenance Phases

Quick Reference

Running slope = 1:16 or 6.25% max

Cross slope = 1:48 or 2.08% max

Changes in level = 1/4 inch max (no bevel)
1/2 inch max (with bevel)

Openings = 1/2 inch max



Measure the clear ground space in all directions with a digital level to ensure it is less than 1:48 or 2.08%. The clear ground space at all accessible play components entry and egress must be level for a child to transfer safely from a wheelchair to the play component.

Once the playground surface is installed, an on-site inspection of the surface system should be conducted along the accessible routes, at the clear ground spaces for entry/egress of equipment and required turning spaces. A digital level can be used to measure the running slope and cross slope. A 2 ft. digital level is most commonly used for accessibility assessments as it can measure greater variances within the cross slope than a longer level. A tape measure can be used to check any changes in level and openings on the accessible route. Changes in level should also be checked at transition points where the surface material changes. The firmness and stability of the playground surface along the accessible route can be measured in the field with a Rotational Penetrometer.



Openings or gaps in the surface cannot exceed a 1/2 inch.



The maximum running slope for the ground level accessible route must not exceed 1:16 or 6.25%. Using a digital level is one option for measuring the slope of the ground level accessible route.



Check for changes in level, especially at transitions between surfaces. Changes in level from 1/4 inch to 1/2 inch must be beveled.



When conducting an assessment of the ground level accessible route, it helps to start with “the big picture” -- to view the play area in its entirety. Begin at the entry to the play area. Identify the accessible play components and the path to entry/egress for each piece of accessible equipment. Then focus in on the accessible route. Each segment of the route should be assessed for compliance with the accessibility standards. Look for the worst areas, those locations where the slope or cross slope may exceed the standard, where changes in level may be too high, or where openings may be too large.

One method to assess the ground level route using the photo above would be to look at each route segment, such as:

- ① From the entry of the play area where the surface begins to the transfer system at the composite play structure.
- ② The clear ground space at the transfer system.
- ③ Segments at each accessible elevated component egress to ground level, the clear ground space at egress, and the connector loop back to the transfer system, such as the segment from the right of the double slide and the clear ground space at the bottom of the slide to the transfer system; and

- ④ The segment to the right of the transfer system to the climbing wall including the transition from the poured in place surface to the engineered wood fiber and the clear ground space at the climber.
- ⑤ The segments from the entry and composite structure to the swings, including the clear ground space at a swing.
- ⑥ Segments to each accessible ground level play component.
- ⑦ Segments to other accessible play areas.

The purpose here is to look for deficiencies in order to make corrective actions. All of the technical provisions must be met through the entire route for it to be considered accessible. Thus, each segment should be assessed for slope, cross slope, change in level, openings, firmness and stability (which will be discussed in greater detail in the next sections). It would be inaccurate and incomplete to only measure slope at one segment, cross slope at another, or to average the data for three segments. Every segment of a route is used by people with disabilities, therefore it is critical that each segment meet the minimum standards.

Measuring Up: Playground Surface Field Testing

Regular inspections of the playground surface and equipment should be conducted to ensure continued safety and accessibility for all users. These inspections should include safety checks, the accessibility assessment of the accessible route, and field testing of the playground surface. Field testing conducted on the playground surface in the use zone should measure the impact attenuation for children who may fall, along with firmness and stability for accessibility to people with disabilities. This field testing should be conducted upon installation and throughout the life cycle of the playground. The Accessibility Standards require the accessible route within the play area comply with two referenced ASTM standards: ASTM F1951-99 Standard Specification for Determination of Accessibility of Surface Systems Under and Around Playground Equipment; and ASTM F1292-99/04 Standard Specification for Impact Attenuation of Surface Systems Under and Around Playground Equipment.

ASTM F1951-99: Lab Test

This is a laboratory test measuring the work force required for a 165 (+11 or -4.4) lb. individual in a manual wheelchair to propel across a given surface.

The lab test uses a 7 percent ramp as a baseline for the wheelchair rider. After the baseline is established, the rider conducts a series of straight propulsions over the sample surface for a minimum distance of 6.56 ft. The force needed to propel the wheelchair rider over the surface is measured. A



The "wheelchair test" is conducted on a sample test bed in the lab to determine the results for ASTM F1951-99.

second series of tests are then run where the wheelchair rider makes a 90 degree turn and the force is measured again. If the average work per foot for the sample surface is *less* than the work force to propel up the 7 percent ramp, the surface sample is considered as passing ASTM F1951-99. The advantage of the ASTM F1951-99 test procedure is that it provides a starting point to compare various surfaces by an objective measurement. However, the primary disadvantage and criticism of the protocol is that it is designed as a lab test in a controlled environment and cannot be easily replicated in the field or outdoors at multiple playground sites. Researchers have attempted to address the portability of this test protocol with the development of the Rotational Penetrometer (RP) described below.

Firmness and Stability: Field Test

While the ASTM F1951-99 protocol does not include a procedure for field testing outdoors at a playground, a field test method has been developed by the same engineering company that developed the original lab test method. A portable instrument known as a Rotational Penetrometer (RP) has been designed to measure the firmness and stability of surfaces. For the purpose of the NCA study, the Rotational Penetrometer was used as the field instrument to measure firmness and stability in lieu of the costly equipment for ASTM F1951-99. Documented research has shown the Rotational Penetrometer to have a high degree of repeatability and reproducibility (ASTM, May 27, 2005; ASTM, September 2010). These research findings also correlate to the lab test.



A Rotational Penetrometer (RP) is used here to measure the firmness and stability of the surfaces.

The RP design includes a wheelchair caster placed on a spring loaded caliber in a metal tripod frame which suspends the caster about 6 inches over the surface. When the caster is released, the spring load gauge replicates the force of an individual in a wheelchair over a given surface. The penetration into the surfaces is measured for readings of “firmness” and “stability.” National experts recognize the use of the Rotational Penetrometer as a portable and relatively easy device to use for surface testing. The field test method with the RP can be added to the assessment process just as measurements for slope, cross slope, change in level and openings are taken along segments of the accessible route for the play area. The RP can measure those segments for firmness and stability. This can be valuable in assessing how an installed surface performs over time.

Impact Attenuation: Lab & Field Test

In the field, ASTM F1292-99/04 Standard Specification for Impact Attenuation of Surface Systems Under and Around Playground Equipment is also known as the “head drop test.” It is a test to make sure the surface is resilient enough to prevent a life-threatening injury from a fall. A 6 inch diameter aluminum hemisphere in the shape of a child’s head is dropped from the top of a tripod based on the fall height of play components. The aluminum hemisphere, or missile as it is called, contains an accelerometer. When dropped, the impact attenuation of the surface is measured in G-max and by the Head Injury Criteria (HIC). G-max is a measurement of the maximum acceleration, while HIC measures an integral of the acceleration time. The maximum values allowable by the standard are 200 for G-max and 1,000 for HIC. A TRIAX is the instrument used to conduct this test in the field.



A TRIAX is used here to test impact attenuation or the play surface’s ability to absorb a fall and reduce severity of injury.

Playground Owners Can Utilize Field Testing to Get the Most Out of Their Surface Installation

The NCA surface study found the need to conduct field testing immediately following installation and throughout the life of the playground surface is critical to insure compliance with ASTM F1292-99/04 and ASTM F1951-99. A surface location can appear to be very accessible by the “look” of it. However, results may be surprising when the surface is actually field tested. This point is illustrated at NCA study sites managed by two different agencies.

One of the participating municipalities manages more than 30 park playgrounds, predominately surfaced with engineered wood fiber (EWF). The park maintenance personnel usually install the EWF by raking it level, allowing it to settle over time and topping off seasonally. The research team found the results for firmness and stability were not consistent with the manufacturer’s ASTM F1951-99 results. The inconsistency was found in the installation process. The research team informed the playground owner of the field test results. Then the park maintenance crew changed their procedure for installation and also began compacting the surface material when it was topped off. Subsequent field testing yielded much better results for firmness and stability.

Another playground owner opted to also have the surface tested for impact attenuation and compliance with ASTM F1292. Drop heights from composite equipment up to 8 ft. high passed the field test. But it was the poured in place (PIP) surface at two swing bays that was found in non-compliance with HIC scores well over the 1,000 HIC allowable under the standard. The playground owner used the terms of the warranty and purchase order as a binding agreement requiring the manufacturer, at its own expense, to return to the site and repair the surface installation. Approximately 2,000 sq. ft. at the swing bays was resurfaced to add more depth to the PIP. When the surface area was retested, the HIC ranged from 650-750 at the swings, well under the 1,000 maximum allowable by the standard. Had the playground owner not discovered the non-compliant surface area until after the warranty had expired, it would have cost the agency in excess of \$35,000 to correct the surface area serving four swings. During the course of the longitudinal study, at least two additional playgrounds surfaced with PIP were found in non-compliance with ASTM F1292. In each case, the playground owners required the installers to return to the site to make corrective actions.

The only way to verify the surface is installed similar to that in which it passed the laboratory test is to conduct field testing.

5 Comparing Surface Options Can Assist Planning Team in Selection Process

Like any big ticket purchase, comparison shopping is essential in the planning process. The planning team should embark on a purposeful mission to determine the playground surface system most appropriate for their site and operational resources. Some agencies may have more capital dollars at the front of the project for a surface system that costs a little more but requires less maintenance. Others may have a smaller project budget for a less costly surface, but have more operational funds for daily/weekly maintenance.

The planning team should engage with all representatives from all surface systems under consideration. Decision-makers should dialogue with the surface supplier regarding realistic, objective measurements to evaluate surface performance and maintain the surface material over the life span of the playground. Decision makers must ask very specific questions to fully benefit from the advantages and costs-savings of a surface system. The dialogue with the manufacturer or sales rep should address:

- Specific written instructions for installation.
- Written description of the base, sub-base and required drainage system.
- Results of ASTM F1951-99 laboratory tests, including the values for the baseline, straight propulsion and turning runs. The test results should also include a description of how the surface was prepared for the lab tests and should be consistent with the installation instructions.
- Results of ASTM F1292-99/04, with written confirmation of the critical fall height for the surface material. These test results should include the depth of the surface material for drop heights. The critical fall height shall be higher than the fall height of the highest equipment on the playground.
- Written description of the maintenance and frequency necessary to maintain the accessible route and clear ground spaces.
- The field test procedures to assess the surface for impact attenuation and accessibility upon initial installation and periodically through the life of the product. This should include selection of an independent testing agent and optimum values for ASTM F1292-99/04 and ASTM F1951-99 when field tested.
- A minimum 5-year warranty that stipulates compliance with ASTM F1292-99/04 and ASTM F1951-99, field testing strategy, limitations, exclusions or preconditions, remedies available to the playground owner, and process for making a claim.

The playground owner should also ask the manufacturer for a list of customers in the area that have installed the surface material in the last 5-10 years. The planning team should talk to those customers and visit older installations to find out what issues may have come up with installation and maintenance.



If the surface system is to be installed by a contractor, those customer sites should also be visited to view the contractor's expertise and craftsmanship. It is important to visit older installations to see how the product has aged and what maintenance issues may have arisen over time.

The chart provided on pages 8-9 describes the playground surfaces included in the NCA surface study: poured in place rubber, rubber tiles, engineered wood fiber and hybrid systems. Other surface materials such as sand, pea gravel and shredded rubber have been used in playground construction. However, if used as part of the ground level accessible route, these surface materials must meet the accessibility standards, including the referenced ASTM standards. Many manufacturers continue to use technology and research to develop new and improved surface systems. The planning team should be on the lookout for new innovations, but at the same time ask questions and visit site installations. This inquiry will give the decision makers a greater understanding of what to expect from different products over the lifespan of the playground.

6 Proper Installation of Playground Surface is Key for Long Term Use and Maintenance

An accessible surface system can be rendered useless if it is not properly installed. Installation of surface systems should be performed by individuals knowledgeable of the accessibility standards and with expertise working with the surface materials. Surface materials/systems can be installed by both contractors and the playground owner's maintenance staff. Some manufacturers require contractors/installers to have special training and/or certification. Poured in place rubber (PIP) is almost exclusively installed by contractors specializing in the surface material. Some playground owners believe the intensive installation requirements for PIP, from mixing the binder to troweling the material level, are best completed by contractors experienced with the surface material. On the other end of the spectrum, engineered wood fiber (EWF) is most frequently installed by park maintenance crews and perceived as relatively easy compared to other surface materials. Somewhere in the middle, tile (TIL) and hybrid systems (HYB) are known to be installed by both contractors and park maintenance personnel.

There is a perception among playground owners that installation of surface systems by their own park crew will produce cost savings for the agency. However, there is a learning curve with the installation process that can prove to be challenging. During the NCA surface study, a playground owner selected a surface based on the perception it would be easy for park crews to install. The first installation was perceived as so difficult for the park maintenance crew that any cost savings was mitigated by the lengthy learning process. By the time the playground owner had installed its fourth playground with TIL, the agency had decided to transition to a different surface. On the contrary, another playground owner that contracted the installation to a preferred manufacturer's installer was very pleased. Intensive installation may mean the contractor is the only one able to make repairs such as those due to vandalism or patches at locations where equipment may have been removed. The costs for return repairs or patches can be dependent upon whether the project is covered under the warranty.

Critical details must be communicated between the design and construction phases, regardless of whether the installation is by contractor or park/facility personnel. Site plans and construction drawings should provide details like maximum running slopes and cross slopes, beveled edges, transitions, adjoining seams and affixing the surface material to the border. Preparation of the base and sub-surfaces should be explained. Lack of attention to drainage or omission of weed barriers between layers can lead to sub-surfaces being washed away, base layers infiltrating top layers, and excessive moisture contributing to the growth of mold and vegetation. All of these issues can affect the usability, the safety and the accessibility of the playground surface. Accessibility deficiencies arising out of installation were associated with all of the surfaces in the NCA study.



The playground site has been graded with earth-moving equipment. The concrete base has been prepared and is awaiting the application of the poured-in-place rubber (PIP) system. At this site, the playground equipment and surface system will be installed by a contractor specializing in playground construction.



The base layer of crumb rubber has been installed. The top layer, a rubber mat system, is fit around equipment and the seams are joined. Both the equipment and surface system at this site will be installed by the park maintenance crew.



Poured in Place Rubber (PIP)

Accessibility deficiencies at PIP sites were commonly found in areas where the granules from the top layer had started flaking off. This flaking condition has been linked to either inadequate ratio of bonding agent to granules when mixed on site; and/or failure of the bonding agent to properly cure when installed at 40 degrees Fahrenheit and falling. The manufacturer installation instructions show the preferred atmospheric temperature for installation to be 40 degrees Fahrenheit and rising. Left unattended over time, areas where the top granular layer has flaked away can lead to non-compliant clear ground space at play equipment such as swings, transfer systems and the egress of slides. Deficiencies related to installation methods may not become evident for months or even years. Thus, it is necessary for the playground owner to prepare for these situations prior to purchase through the terms of the warranty and/or specified funds for maintenance.

Tiles (TIL)

The NCA study identified accessibility deficiencies with TIL most often related to puncture holes ranging from .50 inches to more than 2 inches in diameter and locations where the seams had started to shift or buckle creating openings and changes in level along the accessible route. The puncture holes may be products of intentional vandalism or unintentional damage from users stepping on rocks and other foreign objects with enough force to penetrate the surface. Loose particles are also known for lodging in the TIL seams causing separation at the seams. Left unattended, the particles can lodge so deep in the seams that the adhesive can degrade and the TIL can separate from the concrete subsurface. As the product continues to age, instances of cracking have been identified where either the subsurface or structural integrity of the surface product is compromised. Because TIL are made from rubber product, the surface should

continue to be monitored throughout its life cycle for its ability to meet the impact attenuation requirements of ASTM F1292.

Engineered Wood Fiber (EWF)

Sites installed with EWF were found to have the highest number of accessibility deficiencies within the first year of installation. Because EWF is a loose fill surface, it is frequently observed with accessibility deficiencies related to running slope, cross slope and change in level. EWF has been observed with undulation across the horizon of the surface area. The undulating surface material creates changes in level, running and cross slopes exceeding the maximum allowable standards resulting in non-compliant accessible routes to play components. It is critical for the manufacturer/supplier and the playground owner to communicate the process for installation. In most instances it is necessary for the loose material to be installed in layers, watered and compacted in order to achieve an accessible route and level clear ground space at equipment. Some playground owners consider the installation of EWF as an opportunity to use volunteers to assist in compaction by running drum roller teams across the surface area.

Hybrid Surface Systems (HYB)

Two of the three different types of HYB systems (outdoor carpet and artificial grass) were installed by contractors representing the manufacturers. These surface systems required installers experienced with laying the sub-surface, adjoining seams, and affixing the surface material to the border. Separation at the seams appeared to be the most prevalent concern following installation. Repairs to seams must be made by the contractor and costs are dependent upon the terms of the product warranty.

7 Commitment to Ongoing Care and Maintenance

Maintenance is one of the greatest factors affecting the accessibility of playground surfaces. The accessibility standards require ground surfaces to be inspected and maintained regularly and frequently to ensure continued compliance with ASTM F1951-99. Therefore playground owners should have a thorough understanding of the care and maintenance required for their selected surface systems. Some surface materials may only require seasonal maintenance, while others may require weekly or daily maintenance. The frequency of maintenance is dependent on the surface material and number of users.

The NCA surface study showed there was a lack of installation/maintenance information provided by the manufacturer to the playground owner prior to purchase and there was a steep learning curve related to working with various surface systems. Each of the 16 participating municipalities had maintenance personnel trained through either the National Recreation and Park Association's Certified Playground Safety Inspector program or the Illinois Park District Risk Management Association (PDRMA). The participating agencies recognized maintenance as a critical need in order to provide a safe environment for the public to recreate. All of the municipalities had "playground crews" responsible for visiting each playground site, making visual inspection of the area, collecting trash, and completing repairs as needed. The playground crews ranged in number from 1-3 staff, usually with one full-time employee and 2-3 seasonal staff during the summer months. At least 30 minutes was spent on site. However, the frequency of visits to each site varied among the different agencies. Large playgrounds at regional parks and sites where programming occurred were most often visited. Some were visited daily during peak summer months. Smaller neighborhood parks may have been visited 1-3 times per week or two times per month.

Surface deficiencies were found to exist at each site regardless of the frequency of visits by the playground crew. Maintenance crews should receive training both on the accessibility standards and the care specific to the surface material. Over the course of the longitudinal study, the research team found that where the playground crews became more engaged in the study, the maintenance specific to accessibility began to improve. At least three EWF sites had improved accessibility where the surface material was observed as more level and better compacted than previous site visits. One site utilizing PIP as the primary access route and EWF as the secondary access route was assessed with less than 1 percent slope at the transition between the two surface materials. This was observed as the most improved and maintained transition between surface materials of the sample.



Over time, the unitary surface may separate at the seams or from the border creating gaps, openings or changes in level that will require repair.



Loose fill materials, like EWF, may experience undulation of the surface material and or displacement under heavy use areas with motion such as at swings, slides, sliding pools, climbers, spinners and teeter totters. This will require the surface material to be raked level, filled and compacted so that the clear ground space is level in all directions for a safe transfer onto and off the equipment.

Poured in Place Rubber (PIP)

PIP was recorded as the surface material requiring the fewest instances of maintenance. Maintenance areas were noted where the surface had cracks, buckles, openings or a granular layer had worn away under high traffic areas like swings, transfer steps and the egress at slides. While PIP had the fewest instances requiring maintenance, it is still notable because the surface repairs can be extensive. Repairs must be done by either the original installer or professional certified by the manufacturer resulting in added costs. The patch repairs also necessitate cutting away a larger section of surfacing in order to fill and level the deficient area.

Tiles (TIL)

TIL sites were recorded with a high number of locations in need of maintenance. TIL deficiencies included punctures holes ranging from .50 inches to more than 2 inches in diameter; and instances where the seams had started to shift or buckle creating openings and changes in level along the accessible route. It was unclear whether the puncture holes were products of intentional vandalism or unintentional damage from users stepping on rocks and other foreign objects with enough force to penetrate the surface. Playground owners in the NCA study reported their maintenance crews were able to replace the TIL with puncture holes. Deficiencies were also identified at sites surfaced with a combination TIL and EWF. The intent of the playground design was to use the TIL as the primary accessible route to points of entry/egress and fill the remaining use zone with EWF. The loose fill particles of EWF were scattered throughout the play area, across the tiles, concrete walkway and in the grass. Some of the particles had started to lodge in the TIL seams causing separation at the seams. There were even instances where the particles had lodged so deep in the seams that the adhesive had degraded and the TIL had separated from the concrete subsurface. Over time, these areas would be identified with changes in level and openings requiring repair or replacement of the individual tiles.

Engineered Wood Fiber (EWF)

EWF sites were recorded in need of maintenance most frequently and earliest in the NCA study. Sites surfaced with EWF were commonly found to have an undulating surface material creating changes in level, along with running and cross slopes exceeding the maximum allowable standards. This would result in non-compliant accessible routes to play components. Large areas where the loose material had been displaced under heavy use areas with motion such as at swings, slides, sliding poles, climbers, spinners, and teeter totters were observed at all of the sample sites with EWF. A kick-out area at a swing could be as large as 3 ft. x 8 ft. with a depth of more than 5 inches. The accessibility standards require the minimum 30 x 48 inch clear floor space for transfer to/from the accessible play components to have a level surface with less than a 2.08 percent cross slope in all directions. The displaced surface material at locations such as the bottom of slides, a swing, or ground level play component rendered the accessible route to the play component non-compliant with the accessibility standards. Maintenance issues

at sites began to emerge where the product was filled at the kick-out area rather than the raked level, compacted and then filled and compacted. Where the kick-out areas had been filled, the surface material would eventually be displaced. Over time this created higher undulating mounds at the front and back of the kick-out area and greater cross slopes within the required clear floor space.

At locations where the EWF was paired with a unitary surface, deficiencies were identified at the transition between the two surface materials. The EWF had settled by 1-5 inches creating a change in level and excessive running slope up to 16 percent at the transition. This was most prevalent at sites installed with PIP as the primary access route. At locations where TIL was intended as the primary accessible route and EWF was used as secondary safety surfacing, the EWF particles began contaminating the TIL seams.

To the layman, the terms EWF and woodchips are often, incorrectly, interchanged. The difference between EWF and wood chips are the additional processes beyond the typical landscape chipper. Unlike woodchips out of the chipping equipment, EWF is shredded again, stamped/flattened and made pliable to the extent that the particles will weave together to create a traversable, impact attenuating surface. In addition, there is an ASTM standard specification for EWF (ASTM F2075) further distancing the material from any product made on site or purchased from a nursery or home improvement store. The ASTM standard for EWF requires the particles be small enough to pass through a series of three sieves, ¼ inch, 3/8 inch and No. 16 (0.0469 inch). The sample is considered compliant if no more than 1 percent residue is left on any individual sieve. Large wood particle chips, chunks and shredded twigs were found at all of the EWF sample sites. The observable quantity of large wood particles raised into question whether a test sample from any of the sites would comply with the ASTM standard specification for EWF and specifically the sieve test. In addition to the large particles, there were instances where vegetation and mold were found growing in the surface material.

Hybrid Surface Systems (HYB)

As tested within 12 months of installation, all three HYB surface systems were observed to have minimal deficiencies, comparable to PIP. One of the most commonly noted deficiencies among the HYB was separation at the seams that created openings and changes in level greater than ½ inch. A build up of static electricity was also found to occur seasonally with the artificial grass hybrid system.

*A Longitudinal Study of Playground Surfaces
to Evaluate Accessibility: Final Report
www.ncaonline.org*

What Every Playground Owner Should Know About the Accessibility of Their Playground Surfaces

1 All successful, inclusive playgrounds start with comprehensive planning. The site selection and layout of the accessible route should be considered alongside the selection of the play equipment. A site survey may also be necessary.

2 The accessibility standards apply to playgrounds in parks, malls, schools, child care facilities and other public accommodations covered by the ADA and the ABA. Playground owners, designers and maintenance personnel must have a good understanding of the requirements for ground level accessible routes within the play area.



5 The research findings tell us there is no perfect surface. Each type of surface requires the playground owner understand its characteristics and what is required with installation and maintenance.

6 Proper installation of the playground surface is critical for long term use and maintenance. An accessible surface system can be rendered useless if it is not properly installed. Installation should be performed by those knowledgeable of the accessibility standards and with expertise working with the surface materials. Field testing should be conducted following installation and periodically through the life of the surface system.

7 Playground ownership is a commitment to ongoing care and maintenance. Maintenance is one of the greatest factors affecting the accessibility of playground surfaces. Playground owners should have a thorough understanding of the care and maintenance required for their selected surface systems.



3 Accessibility assessments of the play area should be conducted during planning on paper, installation on site, and for ongoing maintenance. The assessment should include the accessible route throughout the play area along with clear ground space at entry/egress to accessible equipment. The areas should be checked for compliance with running slope, cross slope, changes in level and openings.

4 Comparison shopping is essential in the planning process. Decision makers should engage with suppliers to gather information on various surfaces and evaluate surface options. The sales rep should provide documentation on installation, field testing, maintenance and a minimum 5-year warranty. The planning team should talk to customers and visit installations to find out what issues may have come up with installation and maintenance.



Adapted from *7 Things Every Playground Owner Should Know About the Accessibility of Their Playground Surfaces*, a publication of the U.S. Access Board and the National Center on Accessibility.



amusement rides boating facilities fishing piers & platforms golf courses miniature golf sports facilities swimming pools & spa

accessible swimming pools & spas



a summary of
accessibility guidelines
for recreation facilities

JUNE 2003

A FEDERAL AGENCY COMMITTED TO ACCESSIBLE DESIGN

Contents

Accessibility Guidelines for Recreation Facilities . . .	36
Introduction.....	36
Swimming Pools and Spas	40
Accessible Routes	41
Types of Facilities and Required Means of Entry into the Water.....	42
Types of Accessible Means of Entry into the Water	44
Pool Lifts.....	44
Sloped Entries.....	47
Transfer Walls	49
Transfer Systems.....	51
Accessible Pool Stairs.....	53
Water Play Components.....	54
Other Accessible Elements	54
More Information	55

This information has been developed and reviewed in accordance with the Access Board's information quality guidelines (www.access-board.gov/infoquality.htm).

Accessibility Guidelines for Recreation Facilities

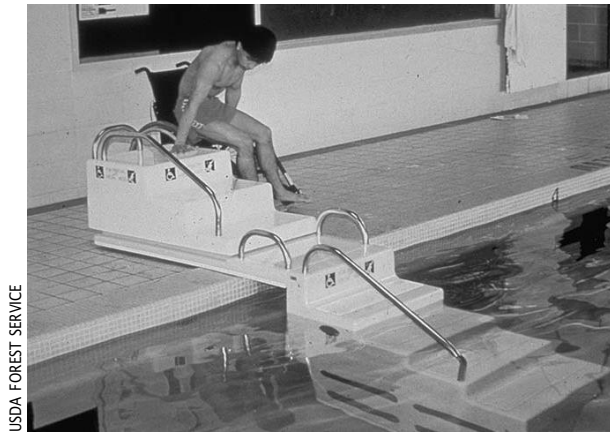

USDA FOREST SERVICE

TRANSFER SYSTEM

Introduction

The Americans with Disabilities Act (ADA) is a comprehensive civil rights law that prohibits discrimination on the basis of disability. The ADA requires that newly constructed and altered state and local government facilities, places of public accommodation, and commercial facilities be readily accessible to, and usable by, individuals with disabilities. The

ADA Accessibility Guidelines (ADAAG) is the standard applied to buildings and facilities. Recreational facilities, including swimming pools, wading pools, and spas, are among the facilities required to comply with the ADA.

The Access Board issued accessibility guidelines for newly constructed and altered recreation facilities in 2002. The recreation facility guidelines are a supplement to ADAAG. As a supplement, they must be used in conjunction with ADAAG. References to ADAAG are mentioned throughout this summary. Copies of ADAAG and the recreation facility accessibility guidelines can be obtained through the Board's website at www.access-board.gov or by calling 1-800-872-2253 or 1-800-993-2822 (TTY).

Once these guidelines are adopted by the Department of Justice (DOJ), all newly designed, constructed and altered recreation facilities covered by the ADA will be required to comply.

The recreation facility guidelines cover the following facilities and elements:

- Amusement rides
- Boating facilities
- Fishing piers and platforms
- Miniature golf courses
- Golf courses
- Exercise equipment
- Bowling lanes
- Shooting facilities
- Swimming pools, wading pools, and spas

This guide is intended to help designers and operators in using the accessibility guidelines for swimming pools, wading pools, and spas. These guidelines establish minimum accessibility requirements for newly designed or newly constructed and altered swimming pools, wading pools, and spas. This guide is not a collection of swimming pool or spa designs.

Rather, it provides specifications for elements within a swimming pool or spa to create a general level of usability for individuals with disabilities. Emphasis is placed on ensuring that



NATIONAL CENTER ON ACCESSIBILITY

individuals with disabilities are generally able to access swimming pools and spas and use a variety of elements. Designers and operators are encouraged to exceed the guidelines where possible to provide increased accessibility and opportunities. Incorporating accessibility into the design of a swimming pool or spa should begin early in the planning process with careful consideration to the accessible routes and means of entry into the water.

The recreation facility guidelines were developed with significant public participation. In 1993, the Access Board established an advisory committee of 27 members to recommend accessibility guidelines for recreation facilities. The Recreation Access Advisory Committee represented the following groups and associations:

- American Ski Federation
- American Society for Testing and Materials (Public Playground Safety Committee)
- American Society of Landscape Architects
- Beneficial Designs
- City and County of San Francisco, California, Department of Public Works
- Disabled American Veterans
- Environmental Access
- Golf Course Superintendents Association of America
- Hawaii Disability and Communication Access Board
- International Association of Amusement Parks and Attractions
- Katherine McGuinness and Associates



- Lehman, Smith, and Wiseman Associates
- Michigan Department of Natural Resources
- National Council on Independent Living
- National Park Service
- National Recreation and Park Association
- New Jersey Department of Community Affairs
- Outdoor Amusement Business Association
- Paralyzed Veterans of America
- Professional Golfer's Association
- Self Help for Hard of Hearing People
- States Organization for Boating Access
- Universal Studios
- U.S. Army Corps of Engineers
- U.S. Forest Service
- Y.M.C.A. of the U.S.A.
- Walt Disney Imagineering

The public was given an opportunity to comment on the recommended accessibility guidelines, and the Access Board made changes to the recommended guidelines based on the public comments. A notice of proposed rulemaking (NPRM) was published in the Federal Register in July 1999, followed by a five-month public comment period. Further input from the public was sought in July 2000 when the Access Board published a draft final rule soliciting comment. A final rule was published in September 2002.

“Whenever a door is closed to anyone because of a disability, we must work to open it... Whenever any barrier stands between you and the full rights and dignity of citizenship, we must work to remove it, in the name of simple decency and justice. The promise of the ADA...has enabled people with disabilities to enjoy much greater access to a wide range of affordable travel, recreational opportunities and life-enriching services.”

President George W. Bush, New Freedom Initiative, February 1, 2001

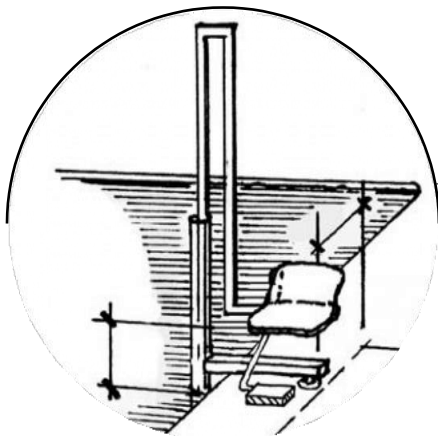

POOL LIFT

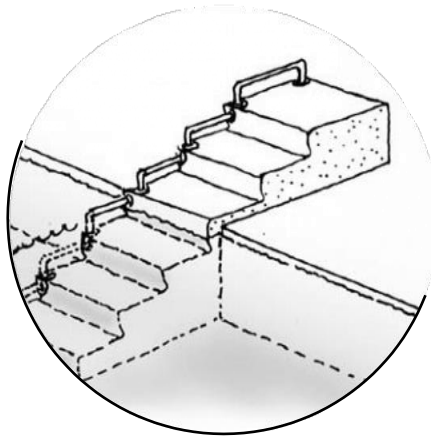

TRANSFER SYSTEM

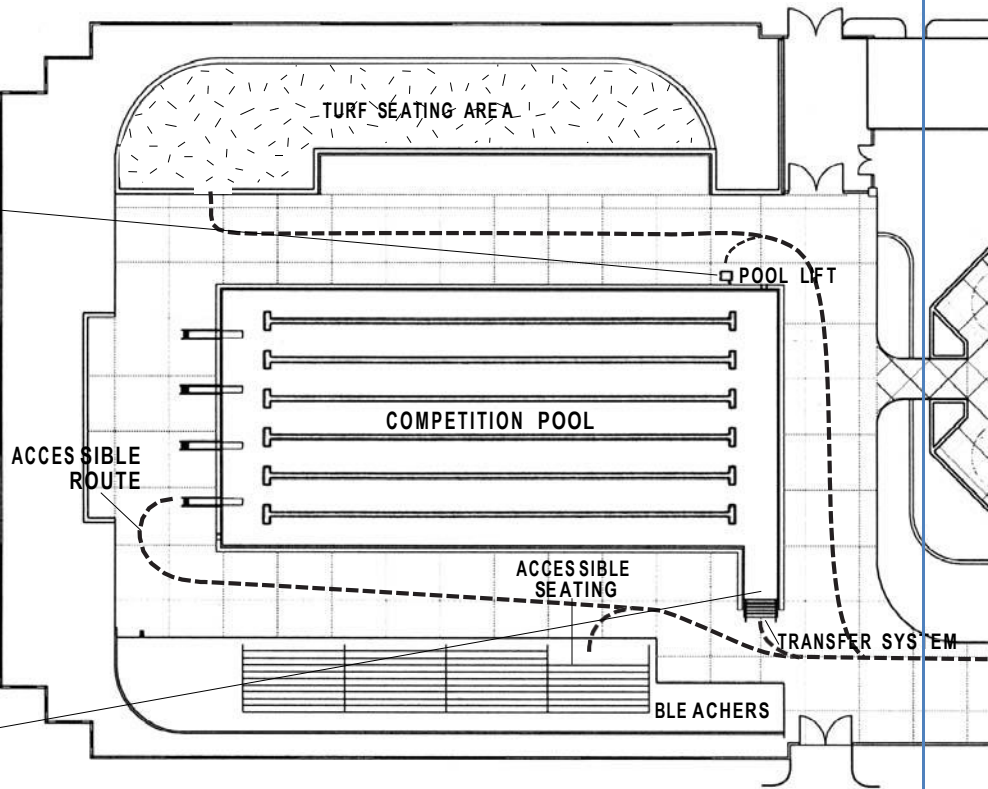

ACCESSIBLE ROUTE CONNECTING ELEMENTS WITHIN A MULTI-USE SWIMMING POOL FACILITY

Swimming Pools and Spas

The guidelines described in this guide focus on newly designed or newly constructed and altered swimming pools, wading pools, aquatic recreation facilities, and spas. Other provisions contained in ADAAG address elements commonly found at a swimming facility, such as accessible vehicle parking spaces, exterior accessible routes, and toilet and bathing

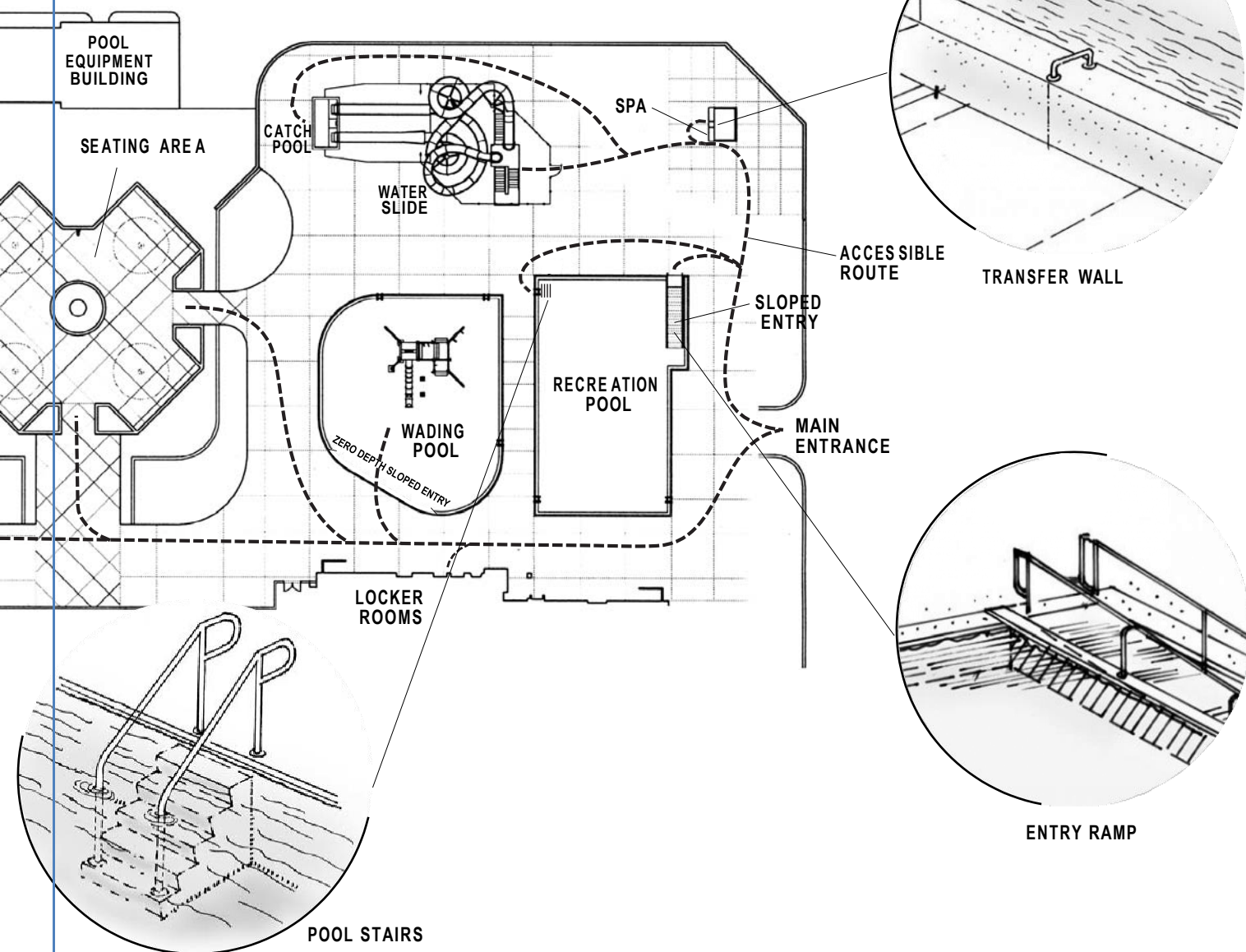

PERMITTED MEANS OF POOL ACCESS					
POOL TYPE	SLOPED ENTRY	LIFT	TRANSFER WALLS	TRANSFER SYSTEMS	STAIRS
Swimming (less than 300 linear feet of pool wall)	✓	✓			
Swimming (300 or more linear feet of pool wall) —two means of entry required	✓*	✓*	✓	✓	✓
Wave action, leisure river, and other pools where user entry is limited to one area	✓	✓		✓	
Wading pools	✓				
Spas		✓	✓	✓	

*Primary means must be by sloped entry or lift, secondary means can be any of the permitted types.

facilities. ADAAG addresses only the built environment (structures and grounds); the guidelines do not address operational issues. Questions regarding operational issues should be directed to the Department of Justice, 1-800-514-0301 or 1-800-514-0383 (TTY).

Accessible Routes

Accessible routes are continuous, unobstructed paths connecting all accessible elements and spaces of a building or facility. Accessible route requirements in ADAAG address width (minimum of 36 inches), passing space, head room, surface, slope (maximum of 1:12 or 8.33%), changes in level, doors, egress, and areas of rescue assistance, unless modified by specific provisions outlined in this guide. An accessible route is required to provide access to the swimming areas and all the supporting amenities. An accessible route is not required to serve raised diving boards, platforms, or water slides.

Types of Facilities and Required Means of Entry into the Water

Swimming Pools

Large pools must have a minimum of two accessible means of entry. A large pool is defined as any pool with over 300 linear feet of pool wall. Pool walls at diving areas and in areas where swimmers cannot enter because of landscaping or adjacent structures are still counted as part of the pool's total linear feet.

The primary means of entry must be either a sloped entry into the water or a pool lift that is capable of being independently operated by a person with a disability. The secondary means of entry could be a pool lift, sloped entry, transfer wall, transfer system, or pool stairs. It is recommended that where two means of entry are provided, they be different types and be situated on different pool walls.

Pools with less than 300 linear feet of pool wall are only required to provide one accessible means of entry, which must be either a pool lift or sloped entry.

Aquatic Recreation Facilities

Wave action pools, leisure rivers, sand bottom pools, and other pools where access to the water is limited to one area and where everyone gets in and out at the same place, must provide at least one accessible means of entry, no matter how many linear feet of pool wall is provided. The accessible

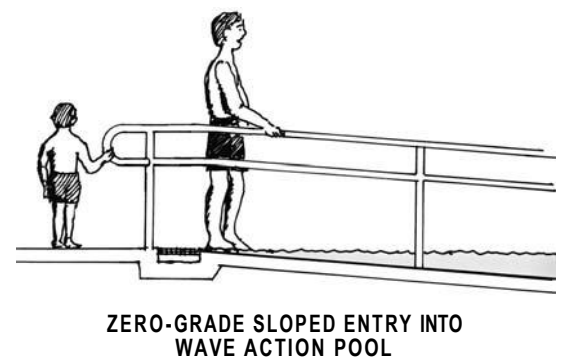
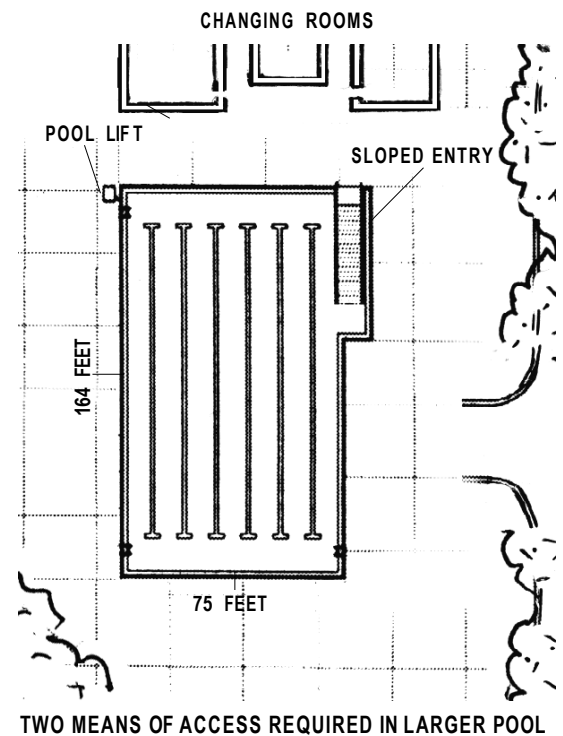



**INDIVIDUAL ENTERING
A WAVE ACTION POOL**

means of entry can be either a pool lift, sloped entry, or transfer system.

Catch Pools

A catch pool is a body of water where water slide flumes drop users into the water. An accessible means of entry or exit is not required into the catch pool. However, an accessible route must connect to the edge of the catch pool.

Wading Pools

A wading pool is a pool designed for shallow depth and is used for wading. Each wading pool must provide at least one sloped entry into the deepest part. Other forms of entry may be provided as long as a sloped entry is provided. The sloped entries for wading pools are not required to have handrails.

Spas

Spas must provide at least one accessible means of entry, which can be a pool lift, transfer wall, or transfer system. If spas are provided in a cluster, 5 percent of the total—or at least one spa—must be accessible. If there is more than one cluster, one spa or 5 percent per cluster must be accessible.

Footrests are not required on pool lifts provided at spas. However, footrests or retractable leg supports are encouraged, especially on lifts used in larger spas, where the water depth is 34 inches or more and there is sufficient space.



LIFT ON A SPA

Types of Accessible Means of Entry into the Water

Pool Lifts

Pool lifts must be located where the water level is not deeper than 48 inches. This provides the opportunity for someone to provide assistance from a standing position in the water if desired. If multiple pool lift locations are provided, only one must be where the water is less than 48 inches. If the entire pool is deeper than 48 inches, an exception allows operators to use a pool lift in any location as an accessible means of entry.

Seats

There are a variety of seats available on pool lifts and these guidelines do not specify the type of material or the type of seat required. However, lift seats must be a minimum of 16 inches wide. In the raised (load) position, the centerline of the seat must be located over the deck, a minimum of 16 inches from the edge of the pool. The deck surface between the centerline of the seat and the pool edge cannot have a slope greater than 1:48.

Although not required, seats with backs will enable a larger number of persons with disabilities to use the lift independently. Pool lift seats made of materials that resist corrosion, that provide a firm base, and that are padded are more usable. Headrests, seat belts, and additional leg support may also enhance accessibility and accommodate a wider variety of people with disabilities.

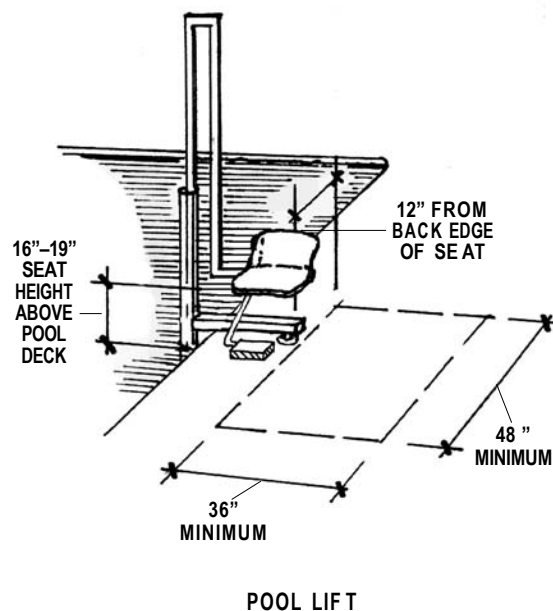



INDIVIDUAL USING A POOL LIFT

Clear Deck Space

Clear deck space must be provided to enable a person to get close enough to the pool lift seat to easily transfer from a wheelchair or mobility device. This clear deck space will ensure an unobstructed area for transfers between a mobility device and the seat. The clear deck space must be a minimum of 36 inches wide and extend forward a minimum of 48 inches from a line located 12 inches behind the rear edge of the seat. This space must be located on the side of the seat opposite the water. The slope of the clear deck space must not be greater than 1:48 (2%). This virtually flat area will make the transfer easier and safer, while still allowing water to drain away from the deck.

Seat Height

The lift must be designed so that the seat will make a stop between a minimum of 16 inches and maximum of 19 inches (measured from the deck to the top of the seat surface, when the seat is in the raised position). Lifts can provide additional stops at various heights to accommodate users of all ages and abilities.

Footrests and Armrests

Footrests and armrests provide stability for the person using the pool lift. Footrests must be provided on pool lifts, and must move together with the seat. Padding on footrests—large enough to support the whole foot—reduces the chance of injury.

Armrests are not required, however if provided, the armrest opposite the water must be removable or be able to fold clear of the seat when the seat is in the raised (load) position. This clearance is needed for people transferring between the lift and a mobility device.

Operation

Lifts must be designed and placed so that people can use them without assistance, although assistance can be provided if needed. A person must be able to call the lift when it is in either the deck or water position. It is especially important for someone who is swimming alone to be able to call the lift so she or he won't be stranded in the water for an extended period of time.

The controls and operating mechanisms must be unobstructed when a lift is in use. A person must be able to use the lift with one hand, and the operating controls must not require tight grasping, pinching, or twisting of the wrist. Controls may not require more than five pounds of pressure to operate.

Submerged Depth

Lifts must be designed so that the seat will submerge to a minimum of 18 inches below the stationary water level. This will ensure buoyancy for the person on the lift and make it easier to enter or exit.

Lifting Capacity

Lifts must have the capability of supporting a minimum weight of 300 pounds and be capable of sustaining a static load that

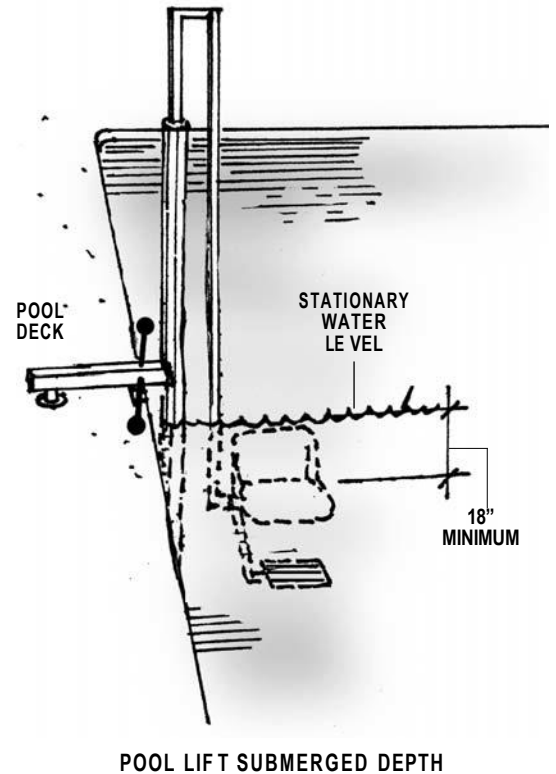

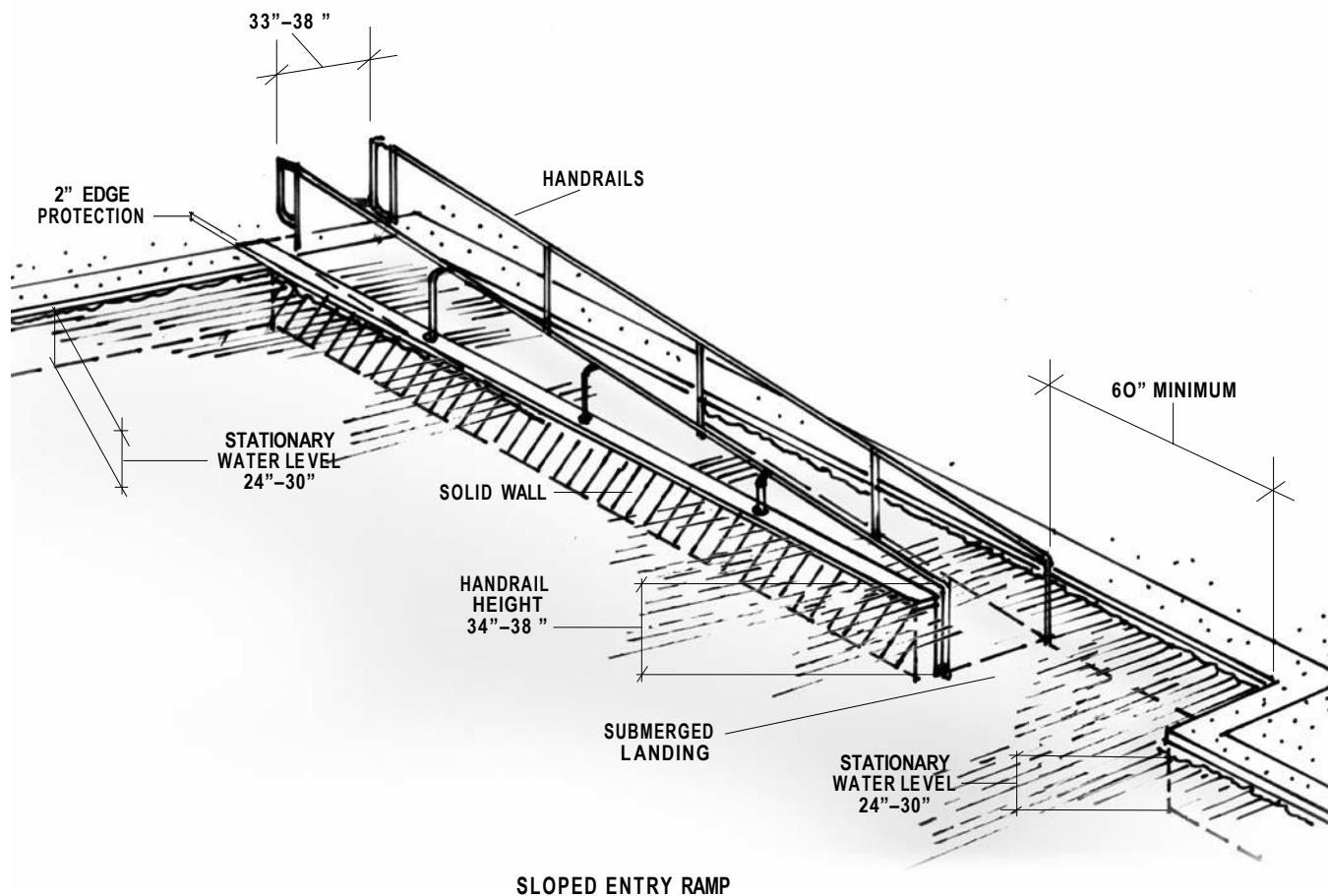

is at least 1.5 times the rated load. Where possible, lifts that can support a greater weight capacity are encouraged.

Sloped Entries

Sloped entries must comply with ADAAG accessible route provisions (36 inch minimum width, maximum 1:12 or 8.33% slope), except that the surface does not need to be slip resistant. The slope may be designed as zero grade beach or ramp access. With either design, the maximum slope permitted is 1:12 (8.33%).

In most cases, it is not appropriate to submerge personal wheelchairs and mobility devices in water. Some have batteries, motors, and electrical systems that can be damaged or contaminate the pool. Facilities that use sloped entries are encouraged to provide an aquatic wheelchair designed for access into the water. Persons transfer to the aquatic wheelchair and access the water using it, leaving their personal mobility device on the deck. Operators and facility managers may need to consider storage options for personal mobility devices if deck space is limited.

Submerged Depth

Sloped entries must extend to a depth between 24 inches minimum and 30 inches maximum below the stationary water level. This depth is necessary for individuals using the sloped entry to become buoyant. Where the sloped entry has a running slope greater than 1:20 (5%), a landing at both the top and bottom of the ramp is required. At least one landing must be located between 24 and 30 inches below the stationary water level. Landings must be a minimum of 36 inches in width and 60 inches in length. The sloped entry may be a maximum of 30 feet at 1:12 (8.33%) slope before an intermediate landing is required. Adding a solid wall on the side closest to the water can enhance safety.

Handrails

Sloped entries must have handrails on both sides regardless of the slope. Handrail extensions are required at the top landing but not at the bottom. The clear width between



INDIVIDUAL USING A SLOPED ENTRY

NATIONAL CENTER ON ACCESSIBILITY

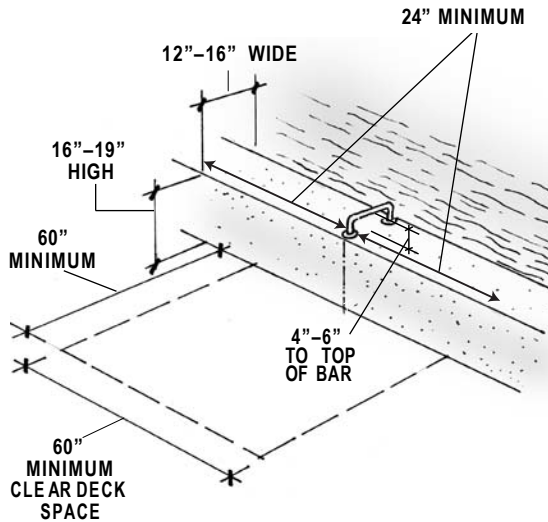

TRANSFER WALL WITH ONE GRAB BAR

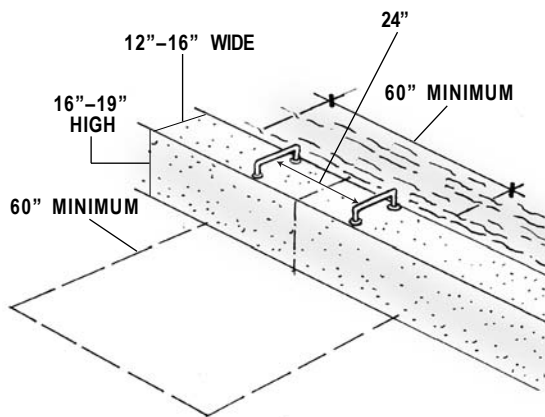

TRANSFER WALL WITH TWO GRAB BARS

handrails must be between 33 and 38 inches. The handrail height must be between 34 and 38 inches to the top of the gripping surface. This provision does not require the handrails to be below the stationary water level, which could be considered an underwater obstruction. No minimum width is required between handrails provided on sloped entries that serve wave action pools, leisure rivers, sand bottom pools, and other pools where people can enter only in one place. Handrails are required to comply with ADAAG provisions (diameter, non-rotating, and height).

Transfer Walls

A transfer wall is a wall along an accessible route that allows a person to leave a mobility device and transfer onto the wall and then into a pool or spa.

Grab Bars

Transfer walls must have at least one grab bar. Grab bars must be perpendicular to the pool wall and extend the full width of the wall so a person can use them for support into the water. The top of the gripping surface must be 4 to 6 inches above the wall to provide leverage to the person using the bars. If only one bar is provided, the clearance must be a minimum of 24 inches on each side of the bar. If two bars are provided, the clearance must be a minimum of 24 inches between the bars. The diameter of the grab bars must comply with ADAAG (diameter between 1.25 and 1.5 inches, not abrasive, and non-rotating).

Clear Deck Space

Clear deck space of 60 by 60 inches minimum, with a slope of not more than 1:48, must be provided at the base of a transfer wall. This will allow persons using a wheelchair to turn around and access the wall, depending on the side they can best use to transfer. If there is one grab bar on a transfer wall, the clear deck space must be centered on the one grab bar. That allows enough space for a transfer on either side of the bar. If two bars are provided, the clear deck space must be centered on the 24-inch clearance between the two bars.

Height

The transfer wall height must be 16 inches minimum to 19 inches maximum, measured from the deck.

Width and Length

Transfer walls must be a minimum of 12 inches wide to a maximum of 16 inches wide. This provides enough space for a person to sit comfortably on the surface of the wall and pivot to access the water. The wall must be a minimum of 60 inches long and must be centered on the clear deck space. Additional length will provide increased space and options for transferring.

Surface

Since people using transfer walls are in bathing suits, their skin may be in contact with the wall. To prevent injuries, the wall surface must have rounded edges and not be sharp.

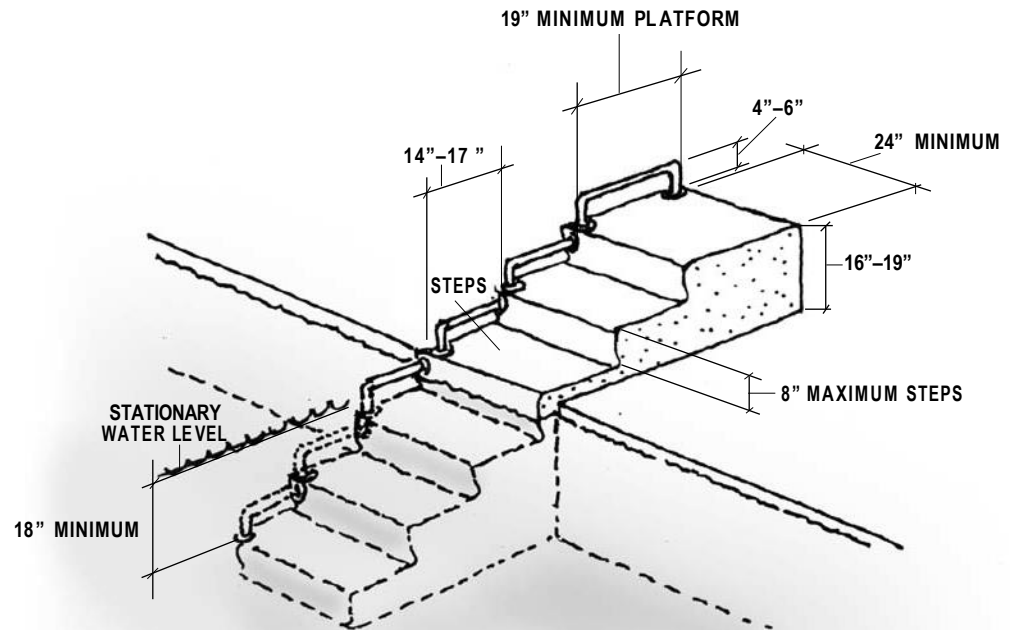

TRANSFER SYSTEM PLATFORM AND STEPS

Transfer Systems

A transfer system consists of a transfer platform and a series of transfer steps that descend into the water. Users need to transfer from their wheelchair or mobility device to the transfer platform and continue transferring into the water, step by step, bumping their way in or out of the pool.

Transfer Platform

Each transfer system must have a platform on the deck surface so users can maneuver on and off the system from their mobility device or wheelchair. Platforms must be a minimum of 19 inches deep by 24 inches wide. That provides

enough room for a person transferring to maintain balance and provides enough space to maneuver on top of it.

Platform Height

Transfer platforms must be between 16 and 19 inches high, measured from the deck.

Clear Deck Space

The base of the transfer platform must have a clear deck space adjacent to it that is 60 by 60 inches minimum, with a slope not steeper than 1:48 so a person using a wheelchair can turn around and maneuver into transfer position. The space must be centered along the 24-inch minimum unobstructed side of the transfer platform. A level, unobstructed space will help a person transferring from a mobility device.

Transfer Steps

The maximum height of transfer steps is 8 inches, although shorter heights are recommended. Each transfer step must have a tread depth of 14 inches minimum to 17 inches maximum and a minimum tread width of 24 inches. The steps must extend into the water a minimum of 18 inches below the stationary water level.

Surface

The surface of the transfer platform and steps must not be sharp and must have rounded edges to prevent injuries.

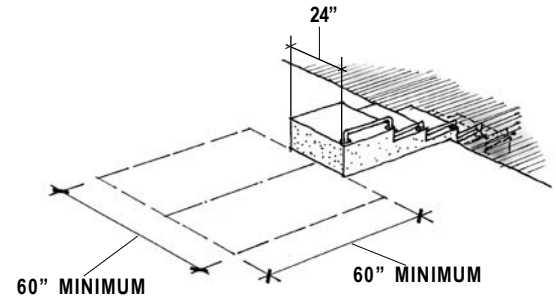

CLEAR DECK SPACE LOCATED AT A TRANSFER SYSTEM

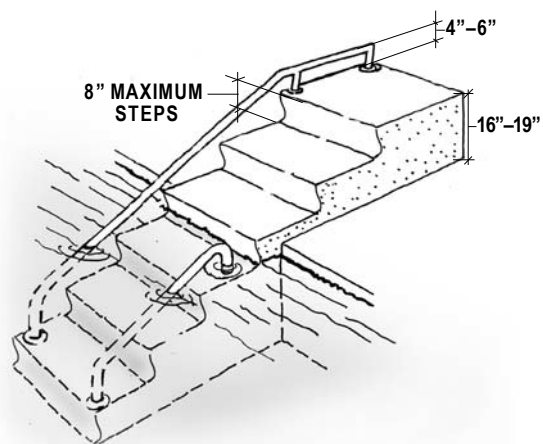

CONTINUOUS GRAB BAR AT
TRANSFER SYSTEM

Grab Bars

A grab bar must be provided on at least one side of each step and on the transfer platform (shown on page 16), or as a continuous grab bar serving each step and the platform (shown at left). The bar must not obstruct transfer onto the platform. If a grab bar is provided on each step, the top of the gripping surface must be 4 inches minimum to 6 inches maximum above each step. If a continuous bar is provided, the top of the gripping surface must be 4 inches minimum to 6 inches maximum above each step nosing. Grab bars on transfer systems must comply with ADAAG (diameter between 1.25 and 1.5 inches, not abrasive, and non-rotating).

Accessible Pool Stairs

Accessible pool stairs are designed to provide assistance with balance and support from a standing position when moving from the pool deck into the water and out. ADAAG provisions for stairs include the requirement that all steps have uniform riser heights and uniform tread widths of not less than 11 inches, measured from riser to riser. Additionally, open risers are not permitted. Other stairs or steps provided in the pool are not required to meet these guidelines.

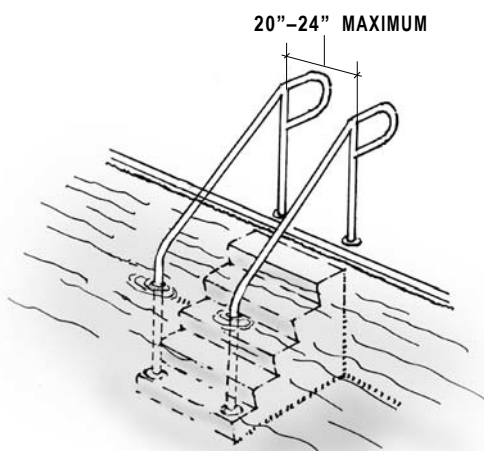

POOL STAIRS

Handrails

Pool stairs must have handrails with a minimum width between the rails of 20 inches and a maximum of 24 inches. The 20- to 24-inch width for the accessible pool stairs is intended to provide support for individuals with disabilities

who are ambulatory. Handrail extensions are required on the top landing of the stairs but are not required at the bottom landing. Handrails on pool stairs must comply with ADAAG provisions. The top of the handrail gripping surface must be a minimum of 34 inches and a maximum of 38 inches above the stair nosing. If handrails are mounted on walls, the clear space between the handrail and wall must be 1.5 inches.

Water Play Components

If water play components are provided, they must comply with the Access Board's Play Area Guidelines and accessible route provisions.

If the surface of the accessible route, clear floor or ground spaces, and turning spaces that connect play components are submerged, the accessible route does not have to comply with the requirements for cross slope, running slope, and surface conditions.

Transfer systems may be used instead of ramps to connect elevated water play components.

Other Accessible Elements

If swimming pools are part of a multi-use facility, designers and operators must also comply with ADAAG and all applicable requirements for recreation facilities. These include, but are not limited to:

- Dressing, fitting, and locker rooms



WATER PLAY STRUCTURE



INDIVIDUAL USING A POOL LIFT

- Exercise equipment and machines
- Areas of sports activities (court sports, sports fields, etc.)
- Play areas
- Saunas and steam rooms

More Information

You can obtain copies of the recreation facility guidelines, which include swimming pools, wading pools, and spas, and further technical assistance from the U.S. Access Board at www.access-board.gov, 1-800-872-2253, or 1-800-993-2822 (TTY).



United States Access Board

1331 F Street, NW, Suite 1000
Washington, DC 20004-1111

voice (800) 872-2253

tty (800) 993-2822

www.access-board.gov



amusement rides boating facilities fishing piers & platforms golf courses miniature golf sports facilities swimming pools & spa

accessible sports facilities



a summary of
accessibility guidelines
for recreation facilities

JUNE 2003

FDA, Inc.

Contents

Accessibility Guidelines for Recreation Facilities . . .	59
Introduction.....	59
Sports Facilities	62
Accessible Routes	64
Dressing, Fitting or Locker Rooms.....	67
Lockers	67
Benches.....	68
Team Player Seating Areas.....	69
Saunas and Steam Rooms	69
Exercise Equipment and Machines	70
Shooting Facilities	71
Bowling Lanes.....	72
More Information	72

This information has been developed and reviewed in accordance with the Access Board's information quality guidelines (www.access-board.gov/infoquality.htm).

Cover photo, center: Scot Goodman

Accessibility Guidelines for Recreation Facilities



KEN & MISAKO AKIMOTO

Introduction

The Americans with Disabilities Act (ADA) is a comprehensive civil rights law that prohibits discrimination on the basis of disability. The ADA requires that newly constructed and altered state and local government facilities, places of public accommodation, and commercial facilities be readily accessible to, and usable by, individuals with disabilities. The ADA Accessibility Guidelines (ADAAG) is the standard applied to buildings and facilities. Recreational facilities, including sports facilities, are among the facilities required to comply with the ADA.

The Access Board issued accessibility guidelines for newly constructed and altered recreation facilities in 2002. The recreation facility guidelines are a supplement to ADAAG. As a supplement, they must be used in conjunction with ADAAG. References to ADAAG are mentioned throughout this summary. Copies of ADAAG and the recreation facility accessibility guidelines can be obtained through the Board's website at www.access-board.gov or by calling 1-800-872-2253 or 1-800-993-2822 (TTY). Once these guidelines are adopted by the Department of Justice (DOJ), all newly designed, constructed and altered recreation facilities covered by the ADA will be required to comply.

The recreation facility guidelines cover the following facilities and elements:

- Amusement rides
- Boating facilities
- Fishing piers and platforms
- Miniature golf courses
- Golf courses
- Exercise equipment
- Bowling lanes
- Shooting facilities
- Swimming pools, wading pools, and spas

This guide is intended to help designers and operators in using the accessibility guidelines for sports facilities. These guidelines establish minimum accessibility requirements for newly designed or newly constructed and altered sports facilities. This guide is not a collection of sports facility designs. Rather, it provides specifications for elements within a sports facility to create a general level of usability for individuals with disabilities. Emphasis is placed on ensuring that individuals with disabilities are generally able to access the sports facility and use a variety of elements. Designers and operators are encouraged to exceed the guidelines where possible to provide increased accessibility and opportunities. Incorporating accessibility into the design

of a sports facility should begin early in the planning process with careful consideration of accessible routes.

The recreation facility guidelines were developed with significant public participation. In 1993, the Access Board established an advisory committee of 27 members to recommend accessibility guidelines for recreation facilities. The Recreation Access Advisory Committee represented the following groups and associations:



- American Ski Federation
- American Society for Testing and Materials (Public Playground Safety Committee)
- American Society of Landscape Architects
- Beneficial Designs
- City and County of San Francisco, California, Department of Public Works
- Disabled American Veterans
- Environmental Access
- Golf Course Superintendents Association of America
- Hawaii Disability and Communication Access Board
- International Association of Amusement Parks and Attractions
- Katherine McGuinness and Associates
- Lehman, Smith, and Wiseman Associates
- Michigan Department of Natural Resources
- National Council on Independent Living
- National Park Service
- National Recreation and Park Association
- New Jersey Department of Community Affairs
- Outdoor Amusement Business Association
- Paralyzed Veterans of America
- Professional Golfer's Association
- Self Help for Hard of Hearing People
- States Organization for Boating Access
- Universal Studios
- U.S. Army Corps of Engineers
- U.S. Forest Service
- Y.M.C.A. of the U.S.A.
- Walt Disney Imagineering



CURT BEAMER

The public was given an opportunity to comment on the recommended accessibility guidelines, and the Access Board made changes to the recommended guidelines based on the public comments. A notice of proposed rulemaking (NPRM) was published in the Federal Register in July 1999, followed by a five-month public comment period. Further input from the public was sought in July 2000 when the Access Board published a draft final rule soliciting comment. A final rule was published in September 2002.

“Whenever a door is closed to anyone because of a disability, we must work to open it.... Whenever any barrier stands between you and the full rights and dignity of citizenship, we must work to remove it, in the name of simple decency and justice. The promise of the ADA...has enabled people with disabilities to enjoy much greater access to a wide range of affordable travel, recreational opportunities and life-enriching services.”

President George W. Bush, New Freedom Initiative, February 1, 2001

Sports Facilities

The recreation facility guidelines described in this guide focus on the accessible features of unique sports-related elements in newly designed or newly constructed and altered facilities. Other provisions contained in ADAAG address elements commonly found within a sports facility, such as accessible vehicle parking spaces, exterior accessible routes, doors, assembly sections, and toilet and bathing facilities. ADAAG addresses only the built environment (structures and grounds). The guidelines do not address operational issues. Questions regarding operational issues should be directed to the Department of Justice, 1-800-514-0301 or 1-800-514-0383 (TTY).



CURT BEAMER

Facilities and elements covered include:

- Areas of indoor and outdoor sports activity, including court sports (such as tennis, volleyball and racquetball), sports fields (such as softball, football, lacrosse, baseball, and soccer) and other sports (such as gymnastics and wrestling)
- Dressing, fitting, and locker rooms
- Team or player seating areas
- Exercise equipment and machines

ACCESSIBLE ROUTE CONNECTING VARIOUS ELEMENTS OF A MULTI-USE FACILITY

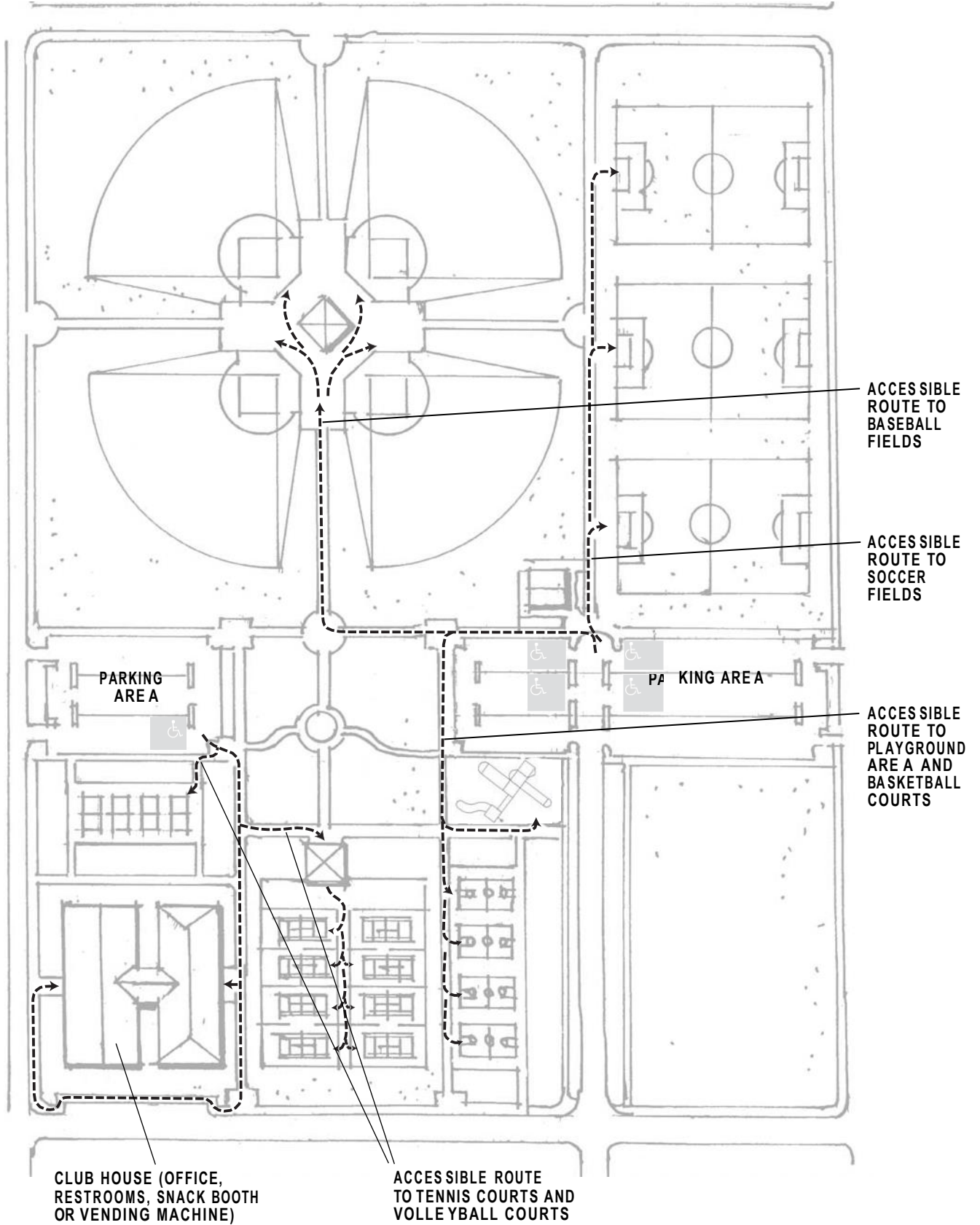



**ACCESSIBLE ROUTE CONNECTING TO
A SPORTS FIELD**

- Saunas and steam rooms
- Animal containment areas for public use such as petting zoos and passageways along animal pens at fairs
- Bowling lanes
- Shooting facilities

These recreation facility guidelines do not apply to:

- Raised structures used for refereeing, judging, or scoring a sport
- Animal containment areas not for public use
- Raised boxing rings and wrestling rings
- Water slides (as long as an accessible route is provided to the base)

Accessible Routes

Accessible routes are continuous, unobstructed paths connecting all accessible elements and spaces of a building or facility. The accessible route must comply with ADAAG provisions for the location, width (minimum of 36 inches), passing space, head room, surface, slope (maximum of 1:12 or 8.33%), changes in level, doors, egress, and areas of rescue assistance, unless otherwise modified by specific provisions outlined in this guide. Facilities must provide accessible routes connecting all accessible elements and spaces within areas of indoor or outdoor sports activities. If not all elements need to be accessible, only those that are accessible must be connected with an accessible route.

The guidelines apply to “fixed” facilities and elements. They do not cover equipment that is frequently moved. For example, a wrestling mat or badminton net may be portable and moved regularly.

Court Sports

Where courts are provided, an accessible route must connect each court. Accessible routes must comply with all ADAAG requirements, such as width and changes in level or surface, and must *directly* connect both sides of the court. Players must not be required to traverse through another court to get to the other side of their court. This is especially critical in sports like tennis, in which changing sides of the court is part of the game. No additional accessibility guidelines apply once on the court.

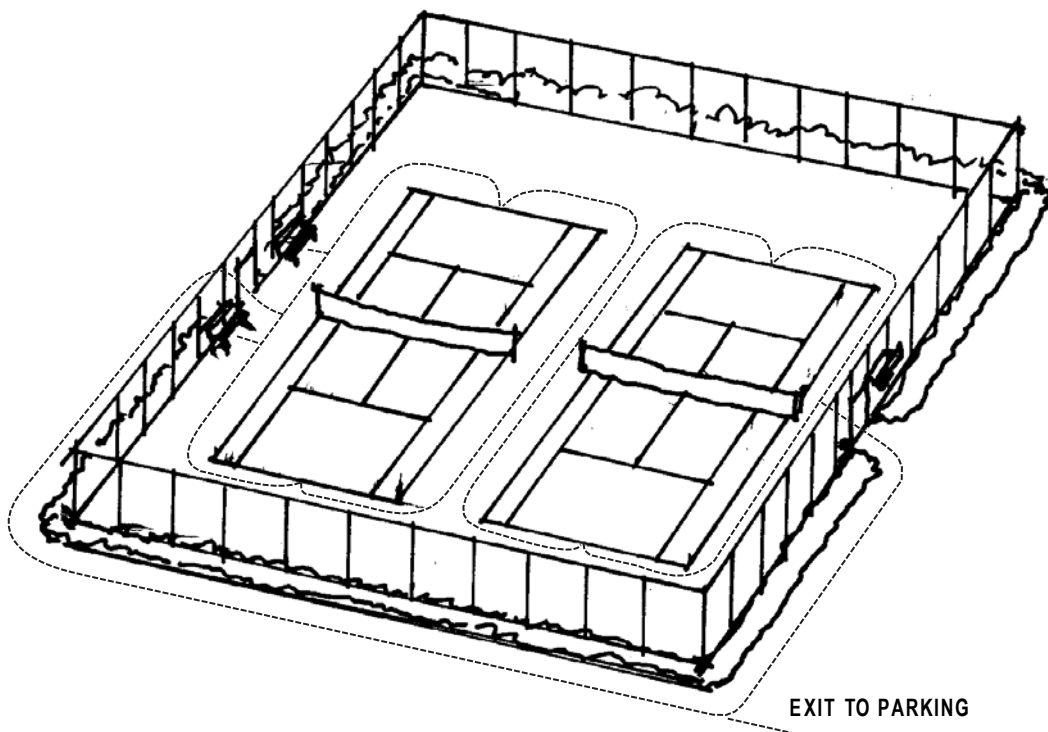

ACCESSIBLE ROUTE CONNECTING COURT SPORTS

Areas of Sport Activities

An “area of sport activity” is a broad term intended to cover a diverse number of indoor and outdoor sports fields and areas. This includes, but is not limited to: basketball courts, baseball fields, running tracks, soccer fields, and skating rinks.

The “area of sport activity” is “that portion of a room or space where the play or practice of a sport occurs.” For example, football fields are defined by boundary lines. In addition, a safety border is provided around the field. Players may temporarily be in the space between the boundary lines and the safety border when they are pushed out of bounds or momentum carries them forward when receiving a pass. So in football, that space is used as part of the game and is included in the area of sport activity.

Accessible routes must connect each area of sport activity. Areas of sport activities must comply with all ADAAG requirements, except that they are exempt from the requirement that surfaces must be stable, firm, and slip resistant, and from the restrictions on carpets, grating, and changes in level. They are also exempt from restrictions on protruding objects. These provisions are not required inside of the area of sport activity since they may affect the fundamental nature of the sport or activity. For example, an accessible route is required to connect to the boundary of a soccer field, but there is no requirement to change the surface of a field to an accessible surface.

Where light fixtures or gates are provided as part of a court sport or other area of sport activity, they must comply with ADAAG provisions for controls and operating mechanisms, and for gates and doors.

Animal Containment Areas

If the public has access to an animal containment area, accessible routes must connect to each animal containment area. Examples may include petting zoos, petting farms, public pathways for viewing livestock display tents, or other areas where the public has access to animals. These areas must comply with all ADAAG requirements, except the requirements that surfaces be stable, firm, and slip resistant and the restrictions on

changes in level since some surfaces need to be absorbent. Accessibility is not required in areas that are for animal handlers and not for public use.

Dressing, Fitting, or Locker Rooms

When provided, dressing, fitting, or locker rooms must be accessible and comply with all ADAAG provisions. If they are in a cluster, 5 percent, or at least one must be accessible. There must be an accessible route through the door and to all elements required to be accessible in the room. Operating mechanisms provided on accessible lockers must also meet ADAAG provisions for their operation and height.

Lockers

If lockers are provided, at least 5 percent, but not less than one of each type (full, half, quarter, etc.) must be accessible. Accessible benches should be located adjacent to the accessible lockers.

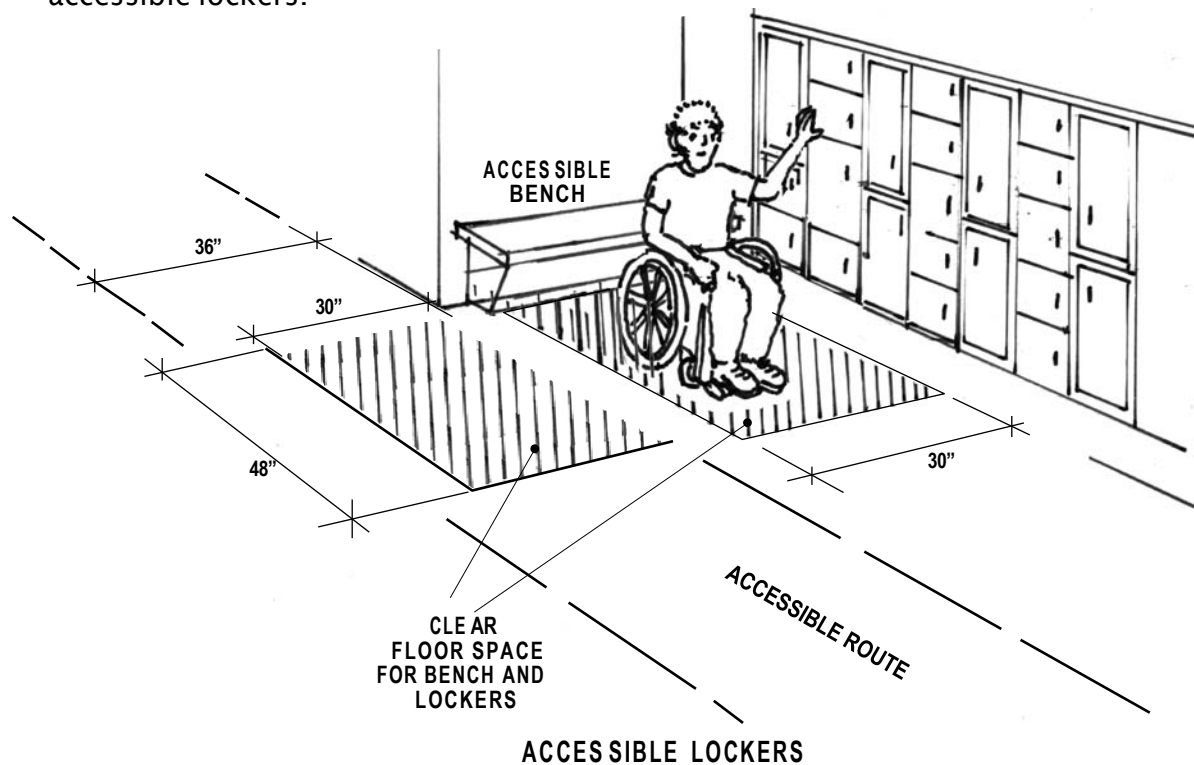

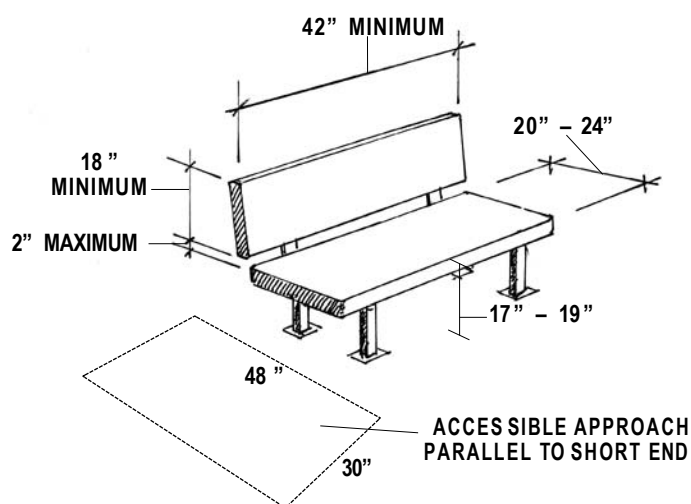

ACCESSIBLE BENCH

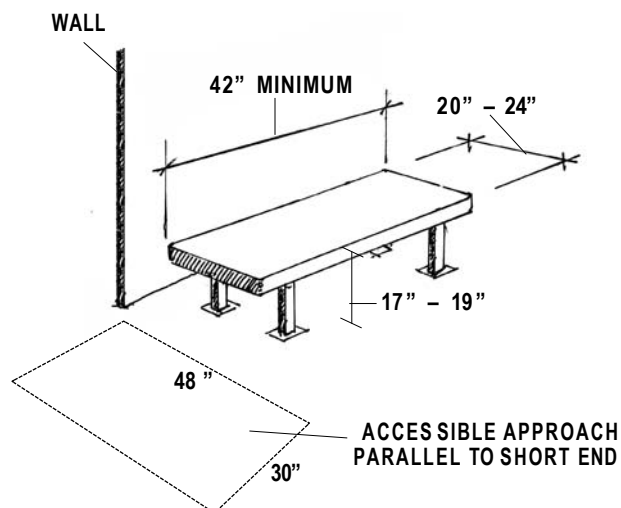

ACCESSIBLE BENCH AGAINST A WALL

Benches

Accessible benches are required in dressing, fitting, and locker rooms, and where seating is provided in saunas and steam rooms. Benches must have a clear floor space positioned to allow persons using wheelchairs or other mobility devices to approach parallel to the short end of a bench seat. In saunas and steam rooms, this floor space may be obstructed by readily removable seats.

Benches must have seats that are a minimum of 20 inches to a maximum of 24 inches in depth and 42 inches minimum in length. The seat height should be a minimum of 17 inches to a maximum of 19 inches above the finished floor. If the bench is not located next to a wall, the bench must have back support that is 42 inches minimum in length and extends from a point 2 inches maximum above the seat to a point 18 inches minimum above the bench. Benches must be strong enough to withstand a vertical or horizontal force of 250 pounds applied at any point on the seat, fastener, mounting device, or supporting structure. The provisions for benches are not intended to apply to park benches or other benches used for sitting or resting.

If benches are located in wet areas, the surface must be slip-resistant and designed not to accumulate water.

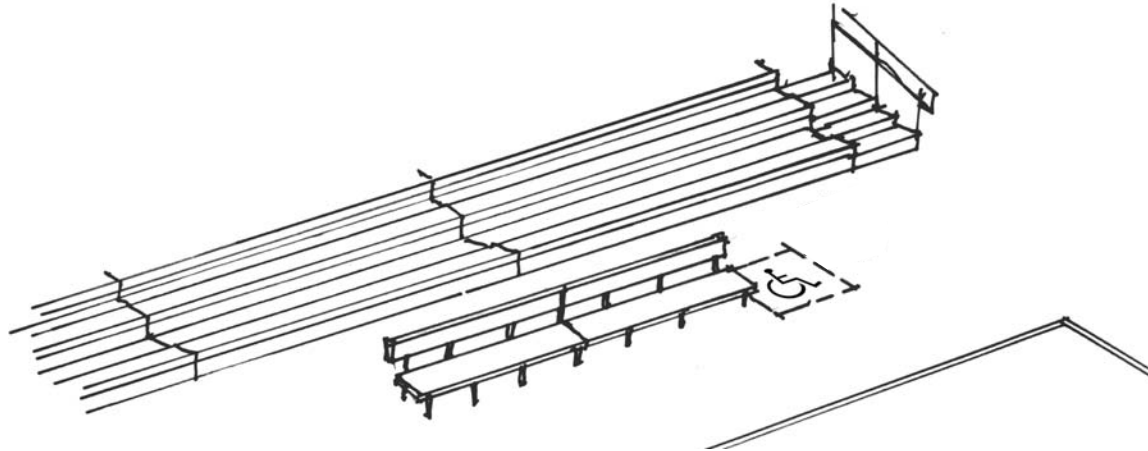

ACCESSIBLE TEAM PLAYER SEATING AREA

Team Player Seating Areas

Where provided, fixed team or player seating areas must contain the number of wheelchair spaces and companion seats required by ADAAG (based on the number of seats provided), but not less than one space. One option is to provide a clear space adjacent to a fixed bench, with the bench serving as companion seating. If designers and operators are designing a field or court that will serve a variety of wheelchair sports, exceeding the minimum requirements will better accommodate participants.

Wheelchair spaces in the team player seating areas are exempt from the requirements related to admission price and line of sight choices in assembly areas. It is recommended that ramps be used wherever possible for accessible routes connecting team or player seating areas and areas of sport activity. However, a platform lift may be used as part of an accessible route to team player seating areas.

Saunas and Steam Rooms

If saunas or steam rooms are in a cluster, at least 5 percent, but not less than one of each type must be accessible. The wheelchair turning space in the sauna or steam room must comply with ADAAG, except that it can be obstructed by readily removable seats. If seating is provided, at least one bench must be accessible. Doors cannot swing into any part of the clear floor or ground space required for benches.

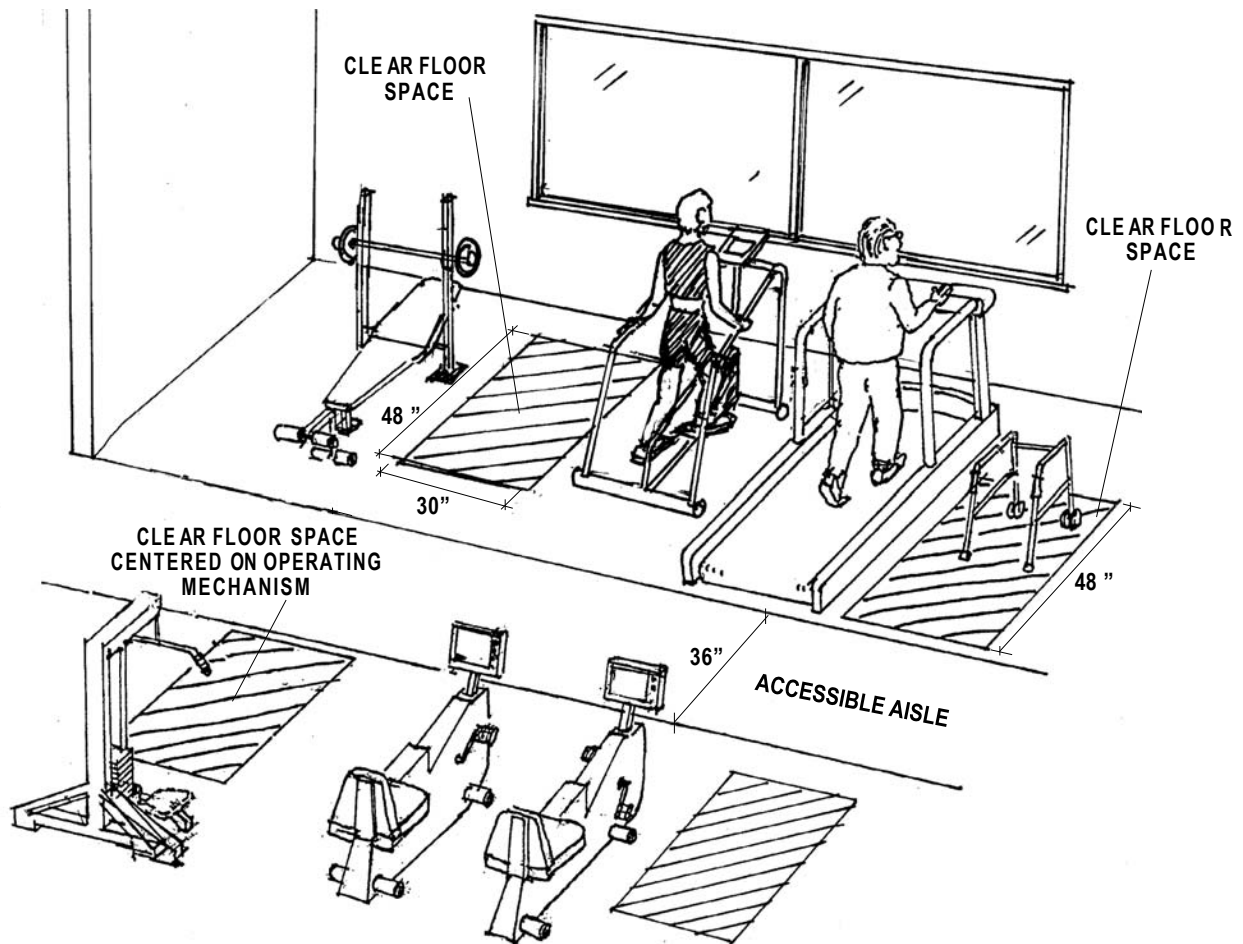

CLEAR SPACE REQUIREMENTS AROUND EXERCISE EQUIPMENT

Exercise Equipment and Machines

At least one of each type of exercise equipment or machine must have clear floor space of at least 30 by 48 inches and be served by an accessible route. If the clear space is enclosed on three sides (e.g., by walls or the equipment itself), the clear space must be at least 36 by 48 inches.

Most strength training equipment and machines would be considered different types. For example, a bench press machine is different from a biceps curl machine. If operators provide both a biceps curl machine and free weights, both must meet the guidelines in this section even though both can be used to strengthen biceps. Likewise, cardiovascular exercise machines, such as stationary bicycles, rowing machines, stair climbers and treadmills, are all different

types of machines. But if the only difference in equipment provided is that they have different manufacturers, but are the same type, only one must comply.

Clear floor space must be positioned to allow a person to transfer from a wheelchair or to use the equipment while seated in a wheelchair. For example, to make a shoulder press accessible, the clear floor space should be next to the seat. But the clear floor space for a bench press designed for use by a person using a wheelchair would be centered on the operating mechanisms. Clear floor space for more than one piece of equipment may overlap. For example, where different types of exercise equipment and machines are located next to other pieces of equipment, the clear space may be shared. (See figure “Clear Space Requirements Around Exercise Equipment” on page 12.)

The exercise equipment and machines themselves do not need to comply with the ADAAG requirements regarding controls and operating mechanisms.

Designers and operators are encouraged to select exercise equipment that provides fitness opportunities for persons with lower body extremity disabilities.

Shooting Facilities

If facilities provide fixed firing positions, at least 5 percent, but not less than one of each type of fixed firing position must be served by an accessible route. Fixed firing positions must have a 60-inch diameter space with slopes not steeper than 1:48 so a wheelchair user can turn around and have a level place from which to shoot.



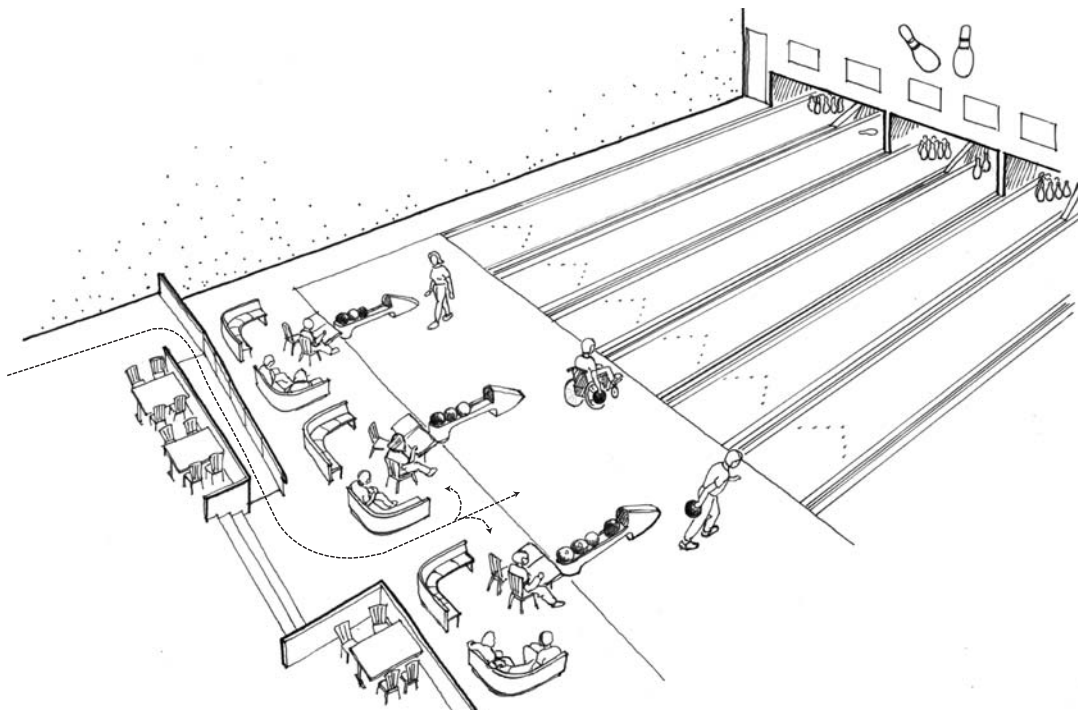

ACCESSIBLE ROUTE CONNECTING ACCESSIBLE LANES AND TEAM PLAYER AREAS

Types of different firing positions include positions with different admission prices, positions with or without weather covering or lighting, and positions that support different shooting events (e.g., muzzle loading rifle, small bore rifle, high power rifle, bull's eye pistol, action pistol, silhouette, trap, skeet, and archery).

Bowling Lanes

At least 5 percent, but not less than one, of each type of bowling lane must be accessible. Unlike other areas of sport activity, only those team or player seating areas that serve accessible lanes must be connected with an accessible route and comply with seating requirements. Spectator seating in bowling facilities is addressed in ADAAG and will require wheelchair spaces, companion seating, and designated aisle seats.

More Information

You can obtain copies of the recreation facility guidelines, which include sports facilities, and further technical assistance from the U.S. Access Board at www.access-board.gov, 1-800-872-2253, or 1-800-993-2822 (TTY).



United States Access Board

1331 F Street, NW, Suite 1000
Washington, DC 20004-1111

voice (800) 872-2253

tty (800) 993-2822

www.access-board.gov



amusement rides boating facilities fishing piers & platforms golf courses miniature golf sports facilities swimming pools & spa

accessible miniature golf



a summary of
accessibility guidelines
for recreation facilities

JUNE 2003

FDA, Inc.

Contents

Accessibility Guidelines for Recreation Facilities . . . 76

 Introduction..... 76

Miniature Golf Courses 80

 Accessible Holes 81

 Accessible Routes 81

 Start of Play Areas 84

 More Information 84

This information has been developed and reviewed in accordance with the Access Board's information quality guidelines (www.access-board.gov/infoquality.htm).

Cover photo, bottom: Atlantic Miniature Golf

Accessibility Guidelines for Recreation Facilities



Introduction

The Americans with Disabilities Act (ADA) is a comprehensive civil rights law that prohibits discrimination on the basis of disability. The ADA requires that newly constructed and altered state and local government facilities, places of public accommodation, and commercial facilities be readily accessible to, and usable by, individuals with disabilities. The ADA Accessibility Guidelines (ADAAG) is the standard applied to buildings and facilities. Recreational facilities, including miniature golf courses, are among the facilities required to comply with the ADA.

The Access Board issued accessibility guidelines for newly constructed and altered recreation facilities in 2002. The recreation facility guidelines are a supplement to ADAAG. As a supplement, they must be used in conjunction with ADAAG. References to ADAAG are mentioned throughout this summary. Copies of ADAAG and the recreation facility accessibility guidelines can be obtained through the Board's website at www.access-board.gov or by calling 1-800-872-2253 or 1-800-993-2822 (TTY).

Once these guidelines are adopted by the Department of Justice (DOJ), all newly designed, constructed and altered recreation facilities covered by the ADA will be required to comply.

The recreation facility guidelines cover the following facilities and elements:

- Amusement rides
- Boating facilities
- Fishing piers and platforms
- Miniature golf courses
- Golf courses
- Exercise equipment
- Bowling lanes
- Shooting facilities
- Swimming pools, wading pools, and spas

This guide is intended to help designers and operators in using the accessibility guidelines for miniature golf courses. These guidelines establish minimum accessibility requirements

for newly designed or newly constructed and altered miniature golf courses. This guide is not a collection of miniature golf course designs. Rather, it provides specifications for elements within a miniature golf course to create a general level of usability for individuals with disabilities. Emphasis is placed on ensuring that individuals with disabilities are generally able to access the miniature golf course and use a variety of elements. Designers and operators are encouraged to exceed the guidelines where possible to provide increased accessibility and opportunities. Incorporating accessibility into

the design of a miniature golf course should begin early in the planning process with careful consideration to accessible holes and accessible routes.

The recreation facility guidelines were developed with significant public participation. In 1993, the Access Board established an advisory committee of 27 members to recommend accessibility guidelines for recreation facilities. The Recreation Access Advisory Committee represented the following groups and associations:



- American Ski Federation
- American Society for Testing and Materials (Public Playground Safety Committee)
- American Society of Landscape Architects
- Beneficial Designs
- City and County of San Francisco, California, Department of Public Works
- Disabled American Veterans
- Environmental Access
- Golf Course Superintendents Association of America
- Hawaii Disability and Communication Access Board
- International Association of Amusement Parks and Attractions
- Katherine McGuinness and Associates
- Lehman, Smith, and Wiseman Associates
- Michigan Department of Natural Resources
- National Council on Independent Living
- National Park Service
- National Recreation and Park Association
- New Jersey Department of Community Affairs
- Outdoor Amusement Business Association
- Paralyzed Veterans of America
- Professional Golfer's Association
- Self Help for Hard of Hearing People
- States Organization for Boating Access
- Universal Studios
- U.S. Army Corps of Engineers
- U.S. Forest Service
- Y.M.C.A. of the U.S.A.
- Walt Disney Imagineering



The public was given an opportunity to comment on the recommended accessibility guidelines, and the Access Board made changes to the recommended guidelines based on the public comments. A notice of proposed rulemaking (NPRM) was published in the Federal Register in July 1999, followed by a five-month public comment period. Further input from the public was sought in July 2000 when the Access Board published a draft final rule soliciting comment. A final rule was published in September 2002.

ACCESSIBLE HOLES 1 THROUGH 8 & 18 (50% OF HOLES)

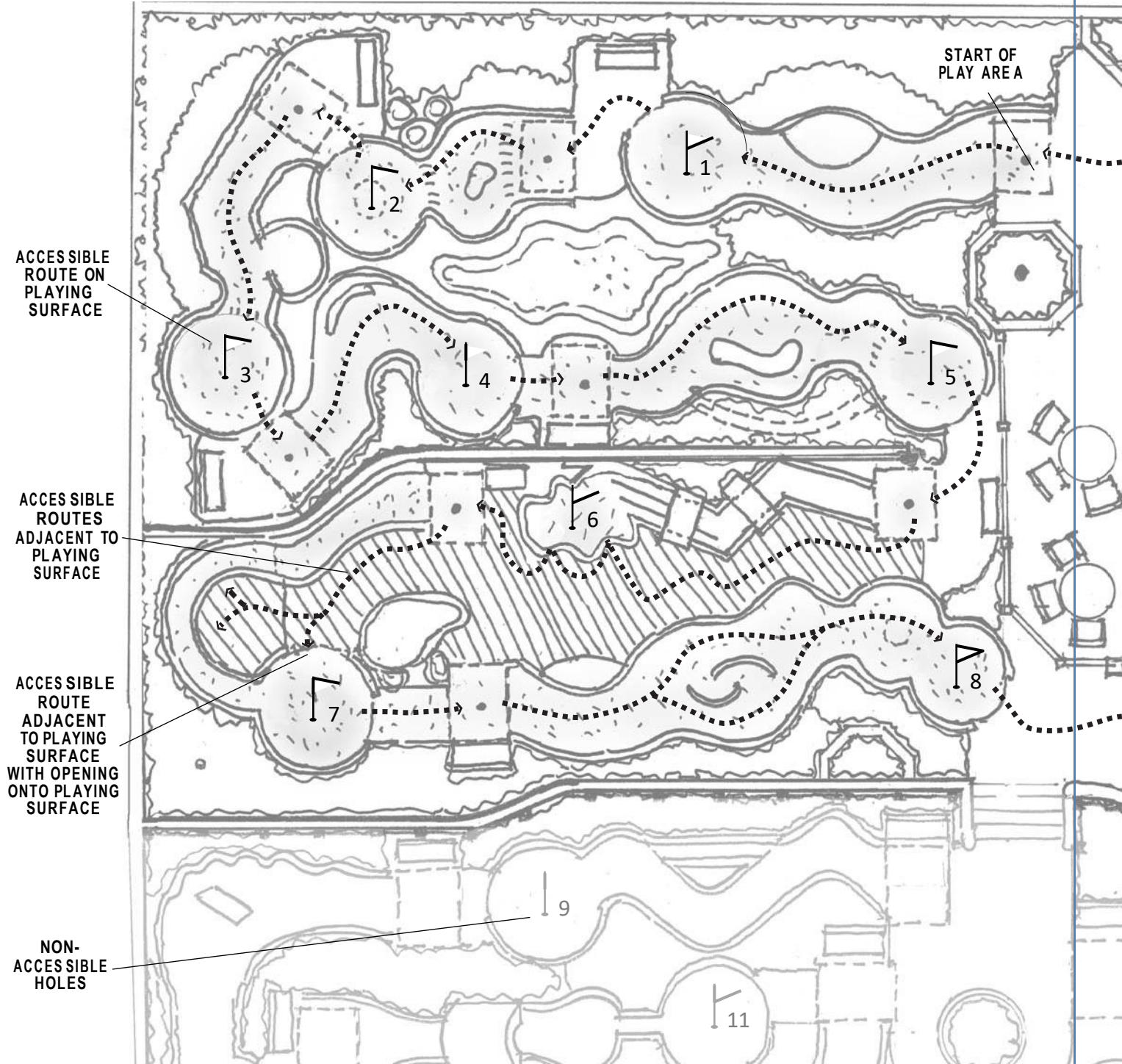

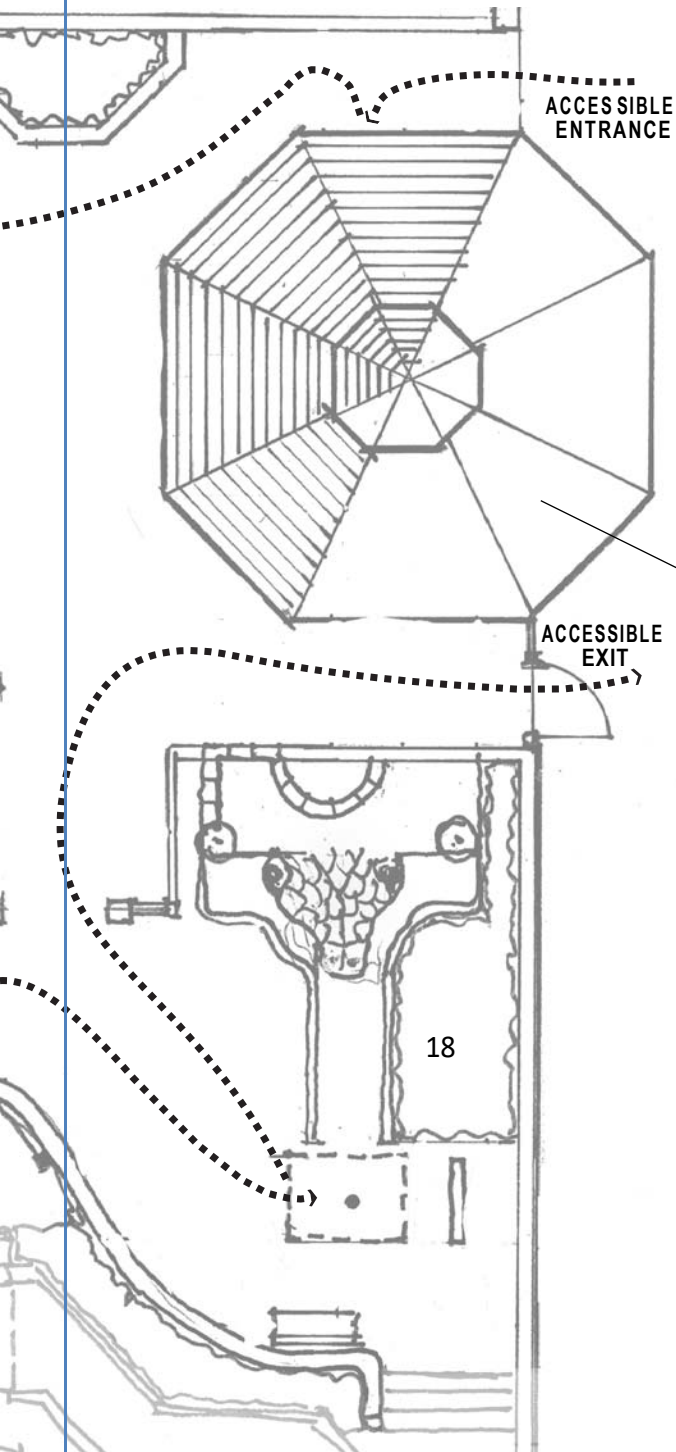

“Whenever a door is closed to anyone because of a disability, we must work to open it.... Whenever any barrier stands between you and the full rights and dignity of citizenship, we must work to remove it, in the name of simple decency and justice. The promise of the ADA. has enabled people with disabilities to enjoy much greater access to a wide range of affordable travel, recreational opportunities and life-enriching services.”

*President George W. Bush, New Freedom Initiative,
February 1, 2001*

CLUB HOUSE
(OFFICE,
RESTROOMS,
SNACK BOOTH
OR VENDING
MACHINE)

Miniature Golf Courses

The recreation facility guidelines described in this guide focus on newly designed or newly constructed and altered miniature golf courses, adventure-style courses, and other putting courses. Other provisions contained in ADAAG address elements commonly found at a miniature golf course facility, such as accessible vehicle parking spaces, exterior accessible routes, and toilet and bathing facilities. ADAAG addresses only the built environment (structures and grounds). The guidelines do not address operational issues. Questions regarding operational issues should be directed to the Department of Justice, 1-800-514-0301 or 1-800-514-0383 (TTY).



INDIVIDUAL STARTING PLAY

Accessible Holes

At least 50 percent of the holes on a miniature golf course must be accessible—if possible, operators should make all holes accessible. Accessible holes must be consecutive, to offer a more socially integrated experience. If only the minimum number of holes are accessible, it is recommended that designers select holes that will offer golfers who use wheelchairs or other mobility devices a playing experience that is as equivalent as possible to the experience of golfers without disabilities.

An exception permits courses to have one break in the sequence of accessible holes, if the last hole in the sequence is the last hole on the course. The route in which a golfer with a disability must travel may not require travel back through any holes, even if the route is adjacent to the hole and not on the hole itself.

Accessible Routes

Accessible routes are continuous, unobstructed paths connecting all accessible elements and spaces of a building or facility. The accessible route must comply with ADAAG provisions for the location, width (minimum of 36 inches), passing space, head room, surface, slope (maximum of 1:12 or 8.33%), changes in level, doors, egress, and areas of rescue assistance, unless otherwise modified by specific provisions outlined in this guide. The accessible route must connect the facility's entrance with the first accessible hole and with start of play area on each following accessible hole.

The course must be configured to allow an easy exit from the last accessible hole to the facility exit or entrance. When not all holes are accessible, a player cannot be required to double back through holes to exit. Where possible, designers and operators are encouraged to make all holes accessible.

An accessible route connecting accessible holes may be on the hole-playing surface or adjacent to it.

Accessible Routes on the Playing Surface

- The surface of the accessible route must be stable, firm and slip resistant. (Where carpets are used on the playing surface, they are not required to comply with the requirements in ADAAG for accessible carpets; however, they are still required to be stable, firm, and slip resistant.)
- There is usually a curb around a hole to keep the ball within the area. When the accessible route is provided on the course, a 1-inch high maximum curb is permitted for an opening of 32 inches minimum where the accessible route extends outside the hole. This opening will permit passage of wheelchairs, while containing the ball within the hole. Designers should consider locating this opening in an area where the ball is not likely to roll.
- The accessible route on a playing surface must be within 36 inches (the golf club reach range) of any area where the ball comes to rest.

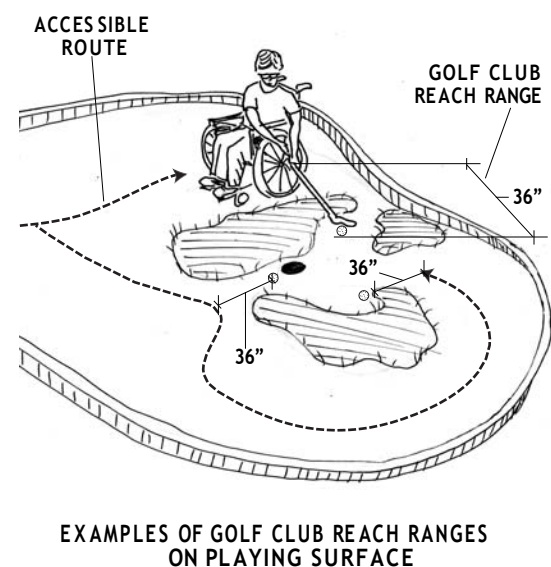
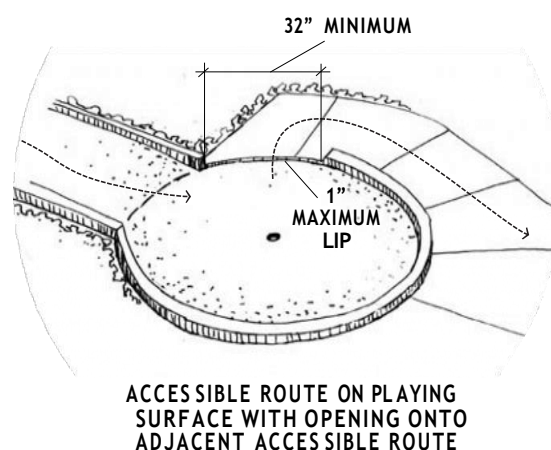

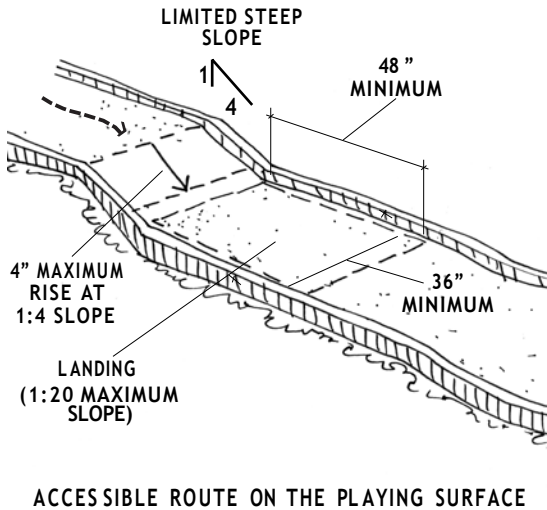

- Landings must be 48 inches long. Where ramps change direction, the landing size must be a minimum of 48 inches by 60 inches. The orientation of the length and the width have not been specified for added flexibility in design. Slopes on landings must be no more than 1:20 (5%).
- If the accessible route is on the playing surface, handrails are not required. The accessible route may include a maximum slope of 1:4 (25%) for a maximum 4-inch rise. These steeper slopes or ramps are permitted for limited distances.

Accessible Routes Adjacent to the Playing Surface

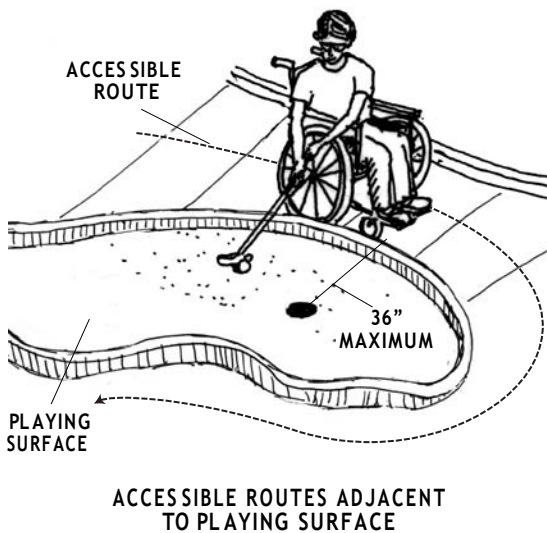

- If the accessible route is adjacent to the playing surface, it must not exceed 36 inches from any area where golf balls rest. This allows players to be close enough to reach the ball and play from outside the hole. The accessible route should be as close to the level playing areas as possible.
- The accessible route adjacent to the playing surface must comply with ADAAG. The accessible route provisions in ADAAG address slope (maximum of 1:12 or 8.33%), width (minimum of 36 inches), cross slope (maximum of 1:50 or 2%), handrails, and changes in level.

Start of Play Areas

The clear floor or ground space area at the start of play for each accessible hole must be 48 by 60 inches minimum to allow players to position themselves for the first shot. It must have a slope no steeper than 1:48 so that people using wheelchairs or mobility devices do not have to hit the ball while positioned on a sloped surface. The accessible route and the clear space can overlap.

More Information

You can obtain copies of the recreation facility guidelines, which include miniature golf courses, and further technical assistance from the U.S. Access Board at www.access-board.gov, 1-800-872-2253, or 1-800-993-2822 (TTY).

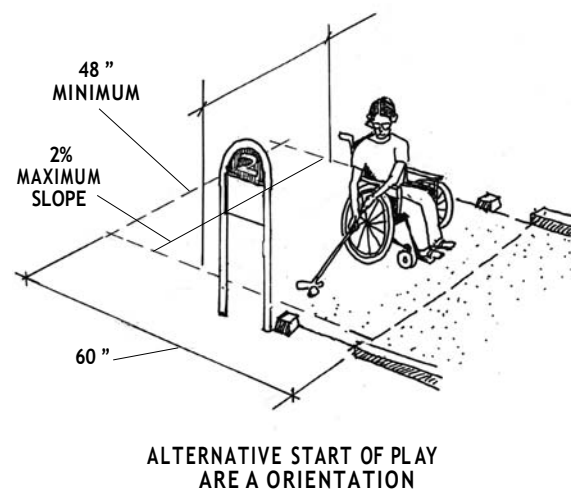
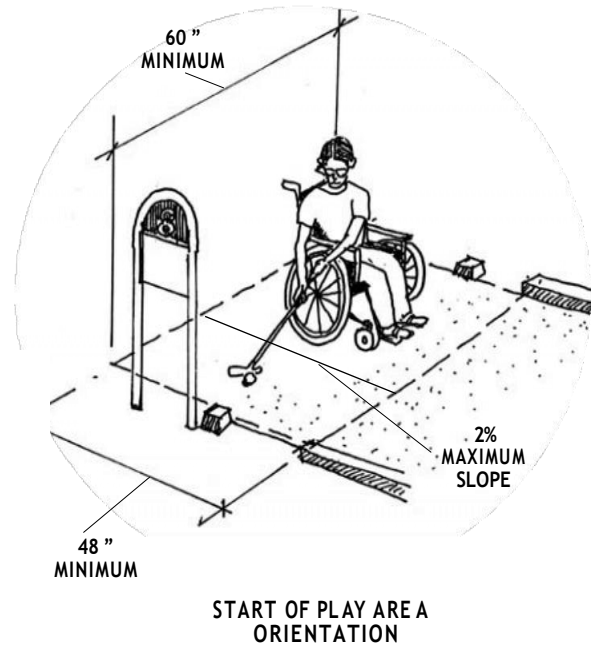



United States Access Board

1331 F Street, NW, Suite 1000
Washington, DC 20004-1111

voice (800) 872-2253
tty (800) 993-2822

www.access-board.gov

ACCESSIBLE PLAY AREAS

A Summary of Accessibility Guidelines for Play Areas



FDA, Inc.



U.S. Access Board
Summary of Accessibility Guidelines
for Play Areas

The Americans with Disabilities Act (ADA) is a comprehensive civil rights law that prohibits discrimination on the basis of disability. The ADA requires that newly constructed and altered State and local government facilities, places of public accommodation, and commercial facilities be readily accessible to, and usable by, individuals with disabilities. Recreational facilities, including play areas, are among the facilities required to comply with the ADA.

The Architectural and Transportation Barriers Compliance Board - often referred to as the "Access Board" - has developed accessibility guidelines for newly constructed and altered play areas. The play area guidelines are a supplement to the Americans with Disabilities Act Accessibility Guidelines (ADAAG). Once these guidelines are adopted as enforceable standards by the Department of Justice, all newly constructed and altered play areas covered by the ADA will be required to comply. These guidelines also apply to play areas covered by the Architectural Barriers Act (ABA).

Summary

This guide is intended to help designers and operators in using the accessibility guidelines for play areas. These guidelines establish minimum accessibility requirements for newly constructed and altered play areas. This guide is not a collection of playground designs. Rather, it provides specifications for elements within a play area to create a general level of usability for children with disabilities. Emphasis is placed on ensuring that children with disabilities are generally able to access the diversity of components provided in a play area. Designers and operators are encouraged to exceed the guidelines where possible to provide increased accessibility and opportunities. Incorporating accessibility into the design of a play area should begin early in the planning process with consideration to layout, circulation paths, and the selection of play components.

The play area guidelines were developed with significant public input and carefully considered the balancing of costs, safety, and accessibility. The Access Board sponsored a Regulatory Negotiation Committee to develop proposed guidelines. The public was given an opportunity to comment on the proposed guidelines and the Access Board made changes to the proposed guidelines based on the public comments. The Regulatory Negotiation Committee represented the following groups and associations:

American Society of Landscape Architects	National Easter Seal Society
ASTM Public Playground Committee	National League of Cities
ASTM Soft Contained Play Committee	National Parent-Teacher Association
ASTM Playground Surfacing Systems Committee	National Recreation and Park Association
International Play Equipment Manufacturers Association	Spina Bifida Association of America
National Association of Counties	TASH
National Association of Elementary School Principals	United Cerebral Palsy Association
National Child Care Association	U.S. Access Board
National Council on Independent Living	

This guide is designed to assist in using the play area accessibility guidelines and is divided into the following sections:

- Where Do the Play Area Guidelines Apply?
- What is a Play Component?
- How Many Play Components Must Be on an Accessible Route?
- What Are the Requirements for Accessible Routes?
- What Other Accessibility Requirements Apply to Play Components?
- Soft Contained Play Structures

Copies of the play area accessibility guidelines and further technical assistance can be obtained from the U.S. Access Board, 1331 F Street, Suite 1000 NW, Washington, DC 20004-1111; 800-872-2253, 800-993-2822 (TTY); www.access-board.gov. Alternate formats of this document are also available upon request.



Play Area terms	89-90
<hr/>	
Where do the Play Area Guidelines Apply?	91-93
<hr/>	
New Construction.....	91
Alterations	91
Equivalent Facilitation	91
Phasing in Play Areas	92
Play Areas Separated By Age.....	93
Geographically Separated Play Areas	93
What is a Play component?	94-98
<hr/>	
Play Components	94
Different “Types”.....	95-96
Elevated Play Components	97
Ground-Level Play Components.....	98
How Many Play components Must Be on An Accessible route?	99-103
<hr/>	
Ground Level Play Components - One of Each Type.....	99
Ground Level Requirements - Based on Elevated Play Components .	100
Elevated Play Components	101
Step-by-Step Guide	102
<hr/>	
Play Area evaluation example	103
<hr/>	
What Are the requirements For Accessible routes?	104-117
<hr/>	
Accessible Routes	104
Ground-Level Accessible Routes.....	105-106
Accessible Ground Surfaces	107
Accessible Surfaces Located in the Use Zone.....	107-108
Elevated Accessible Routes	109
When Ramps Are Required	110-112
When Transfer Systems Are Used	113-116
Connected Elevated Components	117
What other Accessibility requirements Apply to Play components?	118-122
<hr/>	
Clear Floor or Ground Space.....	118
Maneuvering Space.....	119
Entry Points and Seats	120
Play Tables.....	121
Reach Ranges (Advisory)	122
Soft contained Play Structures	123
<hr/>	
Alterations	124
<hr/>	
Acknowledgements	125

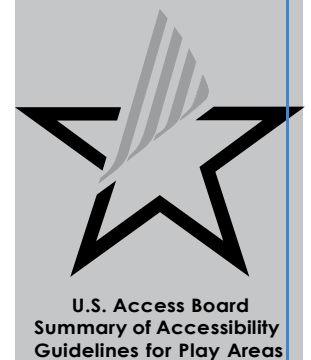

Play Area terms

Many terms are used throughout this guide to describe the play area guidelines. Familiarity with these terms is important when applying the guidelines. Other definitions are provided in ADA/ABA.

ABA - Architectural Barriers Act

Access Board – An independent Federal agency that develops accessibility guidelines under the ADA and other laws. The Access Board is also known as the Architectural and Transportation Barriers Compliance Board.

Accessible – Describes a site, building, facility, or portion thereof that complies with the play area guidelines.

Accessible Route – A continuous unobstructed path connecting all accessible elements and spaces of a building or facility. Inside the boundary of the play area, accessible routes may include platforms, ramps, elevators, lifts. Outside the boundary of the play area, accessible routes may also include parking access aisles, curb ramps, crosswalks at vehicular ways, walks, ramps, and lifts.

ADA – Americans with Disabilities Act.

Alteration – An alteration is a change to a building or facility that affects or could affect the usability of the building or facility or part thereof. Alterations include, but are not limited to, remodeling, renovation, rehabilitation, reconstruction, historic restoration, resurfacing of circulation paths or vehicular ways, changes or rearrangement of structural parts or elements, and changes or rearrangement in the plan configuration of walls and full-height partitions. Normal maintenance is not an alteration unless it affects the usability of the facility (*see section on alterations for more details*).

Amusement Attraction – Any facility, or portion of a facility, located within an amusement park or theme park, that provides amusement without the use of an amusement device. Examples include, but are not limited to, fun houses, barrels, and other attractions without seats.

ASTM – American Society for Testing and Materials.

Berm – A sloped surface at ground level designed to ascend or descend in elevation.

Clear – Unobstructed.

Composite Play Structure – Two or more play structures attached or functionally linked, to create one integral unit that provides more than one play activity (*ASTM F 1487-01*).

Cross Slope – The slope that is perpendicular to the direction of travel (*see running slope*).

Elevated Play Component – A play component that is approached above or below grade and that is part of a composite play structure consisting of two or more play components attached or functionally linked to create an integrated unit providing more than one play activity.



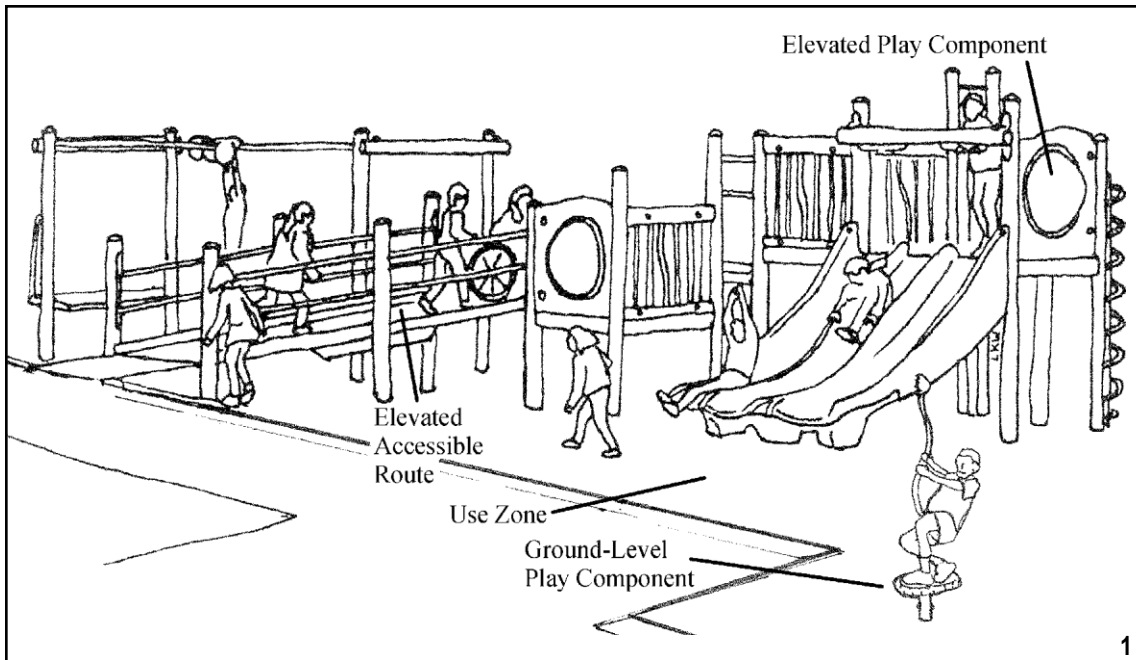

Facility – All or any portion of buildings, structures, site improvements, elements and pedestrian routes or vehicle ways located on a site.

Ground Level Play Component – A play component that is approached and exited at the ground level.

Play Area – A portion of a site containing play components designed and constructed for children.

Play Component – An element intended to generate specific opportunities for play, socialization, or learning. Play components may be manufactured or natural, and may be stand alone or part of a composite play structure.

Ramp – A walking surface that has a running slope of greater than 1:20.

Running Slope – The slope that is parallel to the direction of travel (*see cross slope*).

Site – A parcel of land bounded by a property line or a designated portion of a public right-of-way.

Soft Contained Play Structure – A play structure made up of one or more components where the user enters a fully enclosed play environment that utilizes pliable materials (e.g., plastic, netting, fabric).

Use Zone – The ground level area beneath and immediately adjacent to a play structure or piece of equipment that is designated by ASTM F 1487 Standard Consumer Safety Performance Specification for Playground Equipment for Public Use for unrestricted circulation. This is the play surface upon which it is predicted a user would land when falling from or exiting the equipment.

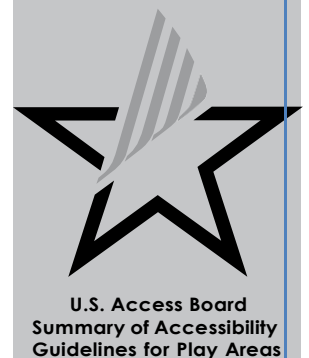

new construction

The play area guidelines in this guide apply to all newly designed or constructed play areas for children ages 2 and older.

This includes play areas located in a variety of settings: parks, schools, childcare facilities, shopping centers, and public gathering areas. Owners or operators of newly constructed play areas are responsible for complying with these guidelines.

The play area guidelines do not apply to:

- Family childcare facilities where the proprietor resides
- Amusement attractions
- Religious entities



This large play area designed for the same age group is part of a public park system. The total of all the play components in this play area - which includes multiple composite structures - must be counted when applying the play area guidelines.

Alterations

The play area guidelines also apply to existing play areas where alterations occur. Further information regarding the application of the play area guidelines to altered play areas can be found on page 39.

equivalent Facilitation

Designs that result in products or technologies as alternatives to those prescribed, provided substantially equivalent or greater accessibility and usability.

Equivalent facilitation is the concept of utilizing innovative solutions and new technology, design, or materials in order to satisfy the guidelines. These alternative solutions provide equal access and take advantage of new developments, but may differ technically from specific guidelines.



Phasing in Play Areas

When play areas are constructed in phases, they must continue to meet the play area guidelines throughout construction. The initial phase area must meet the guidelines, and then at each successive phase the whole play area must be reassessed to assure compliance.

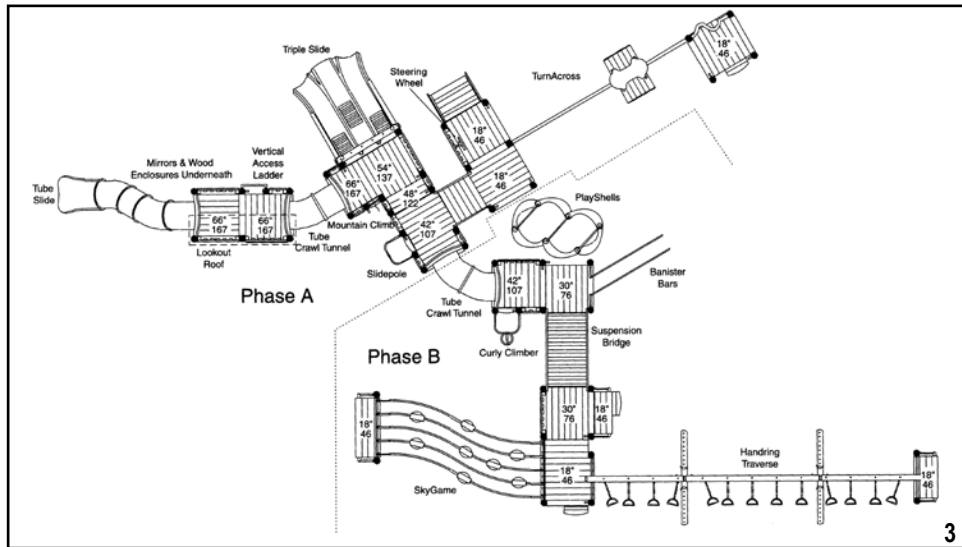

This play area will be installed in two phases. As each phase is completed, the entire play area must be reevaluated for compliance.

Prior to phase one, the first structure is evaluated for compliance, since the guidelines are based on a minimum number of play components required to be on an accessible route.

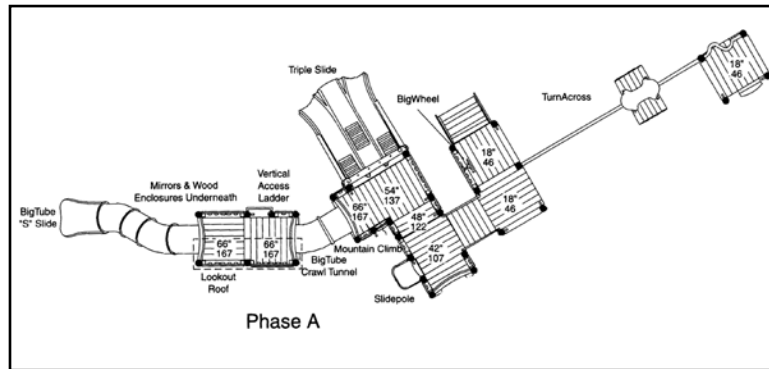

At the onset of phase two, the play area is reevaluated in its entirety.

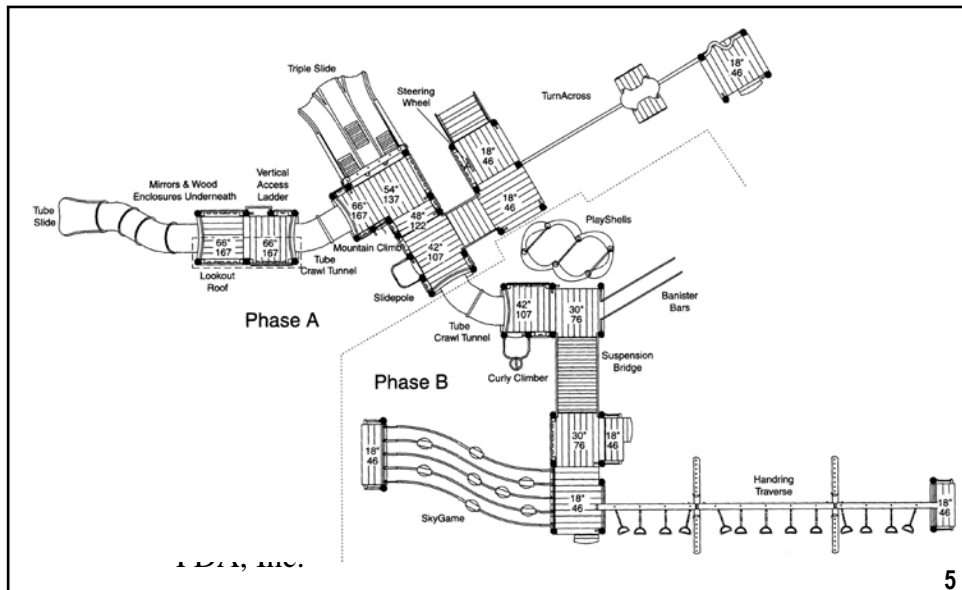

“Phased designs” are play areas developed to be installed in different stages, allowing the play area to grow in a planned manner while accommodating budgets, fund raising, or community approval processes.

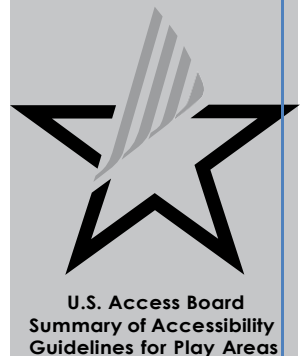

Play Areas Separated by Age

To reduce the risk of injury, safety guidelines recommend separate play areas for different age groups. In applying the guidelines, play areas designed for different age groups should be considered separately.

A play area designed for 2 to 5 year-olds is considered separate from one for 5 to 12 year-olds. Therefore, compliance with the guidelines must be considered for each individual play area.



This dual play area designed for 2 to 5 year-olds and 5 to 12 year-olds shares resilient surfacing. Each section must be evaluated separately.

Geographically Separated Play Areas

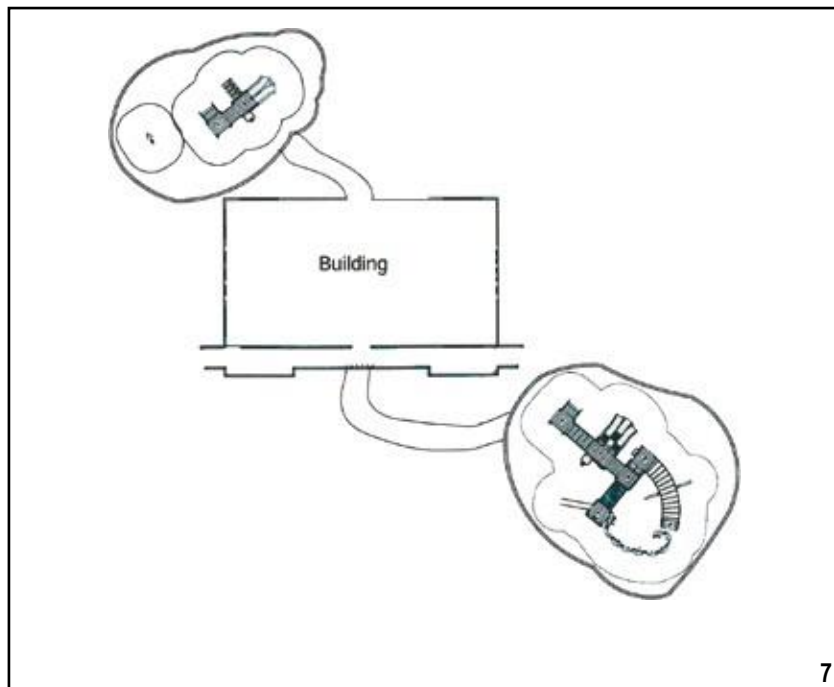

Large geographical spaces may contain several play areas within one park setting. Where play areas are geographically separated on a site, they are considered separate play areas. The accessibility guidelines apply to each play area.



Play components

A play component is an element designed to generate specific opportunities for play, socialization, and learning. Play components may be manufactured or natural, and may be stand alone or part of a composite play structure. Swings, spring riders, water tables, playhouses, slides, and climbers are among the many different play components.

For the purpose of these guidelines, ramps, transfer systems, steps, decks, and roofs are not considered play components. These elements are generally used to link other elements on a composite play structure. Although socialization and pretend play can occur on these elements, they are not primarily intended for play.



Spring rider



Climber



Swing



Slide

When applying the play area guidelines, it is important to identify the different play experiences play components can provide.

different “types”

At least one of each type of play component provided at ground level in a play area must be on an accessible route.

Different “types” of play components are based on the general experience provided by the play component. Different types include, but are not limited to, experiences such as rocking, swinging, climbing, spinning, and sliding.

“Rocking” is an example of horizontal movement that can be backwards, forwards, sideways or even circular in nature.

“Sliding” is an example of rapid descent that utilizes the force of gravity.



A Swinging Type



A Rocking Type



This single play component provides one type of play experience for multiple individuals.



The number of individuals who can play on a play component at once does not determine the quantity of play components provided in a play area. A play component can hold many children but is considered one type of play experience - or one play component - in the play area.



Examples of Sliding Types

While a spiral slide provides a slightly different experience from a straight slide, the primary experience - a sense of rapid descent or sliding - is common to both activities. Therefore, a spiral slide and a straight slide are considered one “type” of play experience.

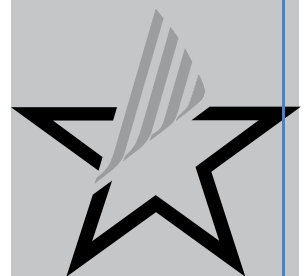

elevated Play components

An elevated play component is a play component that is approached above or below grade and is part of a composite play structure. Play components that are attached to a composite play structure and that can be approached from a platform or deck area are considered elevated play components.



This climber is considered an elevated component, since it can be approached or exited from the ground level or above grade from a platform or deck on a composite play structure.



Ground-level Play components

Ground-level play components are items that can be approached and exited at ground level. For example, a child approaches a spring rider at ground level via the accessible route. The child may ride then exit directly back onto the accessible route. The activity is considered ground level because the child approaches and exits it from the ground-level route.



Ground-level play components may be part of a composite structure.



Ground-level components may also be free-standing in a play area.

When more than one ground-level play component is required on an accessible route, the play components must be integrated. Designers should consider the optimal layout of ground-level play components to foster interaction and socialization among all children. Grouping all ground-level play components accessed by children with disabilities in one location does not constitute integration.

“Ground-level components” are approached and exited at ground level.

Ground-level play components may include items such as swings, spring riders, and panels.

Freestanding slides are considered ground-level components for the purpose of these guidelines. An accessible route must connect to the ladder or steps, and to the exit of the slide. While this solution does not provide access for all children, it gives many individuals the opportunity to access play components.

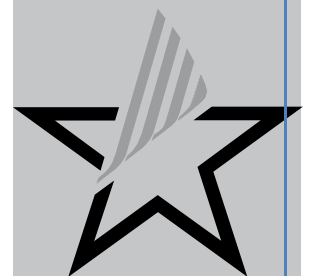

U.S. Access Board
Summary of Accessibility
Guidelines for Play Areas

Ground-level Play components

There are two requirements addressing how many ground-level play components must be on an accessible route:

- One of Each Type
- Ground-Level Requirements based on the number of Elevated Play Components

one of each type

At least one of each type of ground-level play component that is present in the play area must be on an accessible route.

As an example, this play area includes a composite play structure, two spring riders and a swing set (see inset). To meet the requirement, an accessible route must connect to at least one spring rider and one swing for one of each type of ground-level play experiences which are present in the play area.

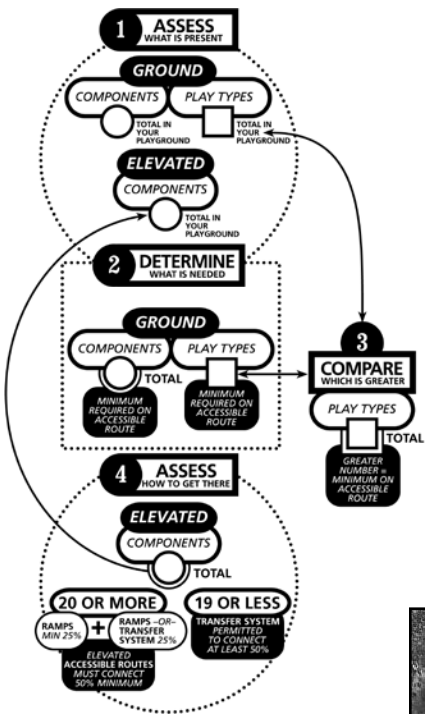

The above step-by-step guide is intended to assist when applying the play area guidelines. A detailed description is provided on page 17.

A “ground-level play component” is a play component that is approached and exited at the ground level.



U.S. Access Board
Summary of Accessibility
Guidelines for Play Areas

Ground level requirements

Based on elevated Play components

The number and variety of ground-level play components required to be on an accessible route is also determined by the number of elevated components provided in the play area.

The intent of this requirement is to provide a variety of experiences for individuals who choose to remain with their mobility aids, or choose not to transfer to elevated play components.

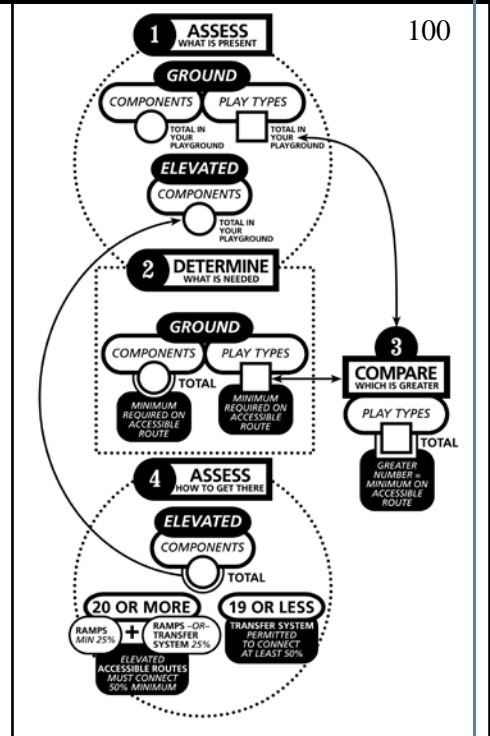

Number of elevated play components provided	Minimum number of ground-level play components required to be on accessible route	Minimum number of different types of ground-level play components required to be on accessible route
1	Not applicable	Not applicable
2 to 4	1	1
5 to 7	2	2
8 to 10	3	3
11 to 13	4	3
14 to 16	5	3
17 to 19	6	3
20 to 22	7	4
23 to 25	8	4
More than 25	8 plus 1 for each additional 3 over 25, or fraction thereof	5

If ramps provide access to at least 50 percent of the elevated play components - which must include at least three different play types - then additional ground-level components are not required.

In the play area shown on page 14, the composite structure has four elevated play components (bubble panel, slide, steering wheel, and tic-tac-toe panel). According to the table, a minimum of one ground level play component must be provided, and a minimum of one different type. The spring rider or swing can be used to meet the “one of each type” requirement and can also be used to meet the minimum number determined by Table 240. 2.1.2.



elevated Play components

At least 50 percent of the elevated play components must be on an accessible route.



24

Play areas with 20 or more elevated components must use ramps to connect a minimum of 25 percent of those components. A transfer system or ramps may connect the other elevated play components required on an accessible route.

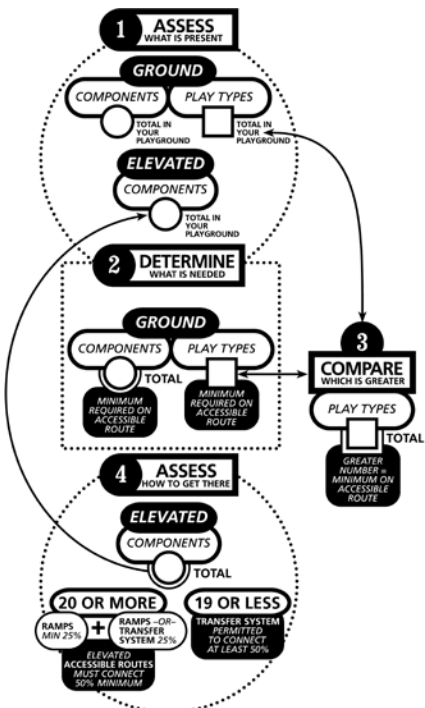

The above step-by-step guide is intended to assist when applying the play area guidelines. A detailed description is provided on page 17.

An “elevated play component” is a play component reached from above or below grade, and is part of a composite play structure.



25

Play areas with less than 20 elevated play components may use a transfer system instead of ramps to connect at least 50 percent of the elevated components.



U.S. Access Board
Summary of Accessibility
Guidelines for Play Areas

Step-by-Step Guide

The following step-by-step guide has been provided to assist in evaluating a play area for meeting the minimum requirements of these guidelines. The guide has been arranged in four steps and provides spaces to fill in numeric values of play components for evaluating a specific play area design.

The step-by-step guide is used throughout the remainder of this guide as a key, shown in the upper corner of each new section where it applies.

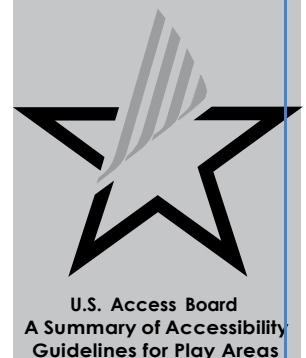
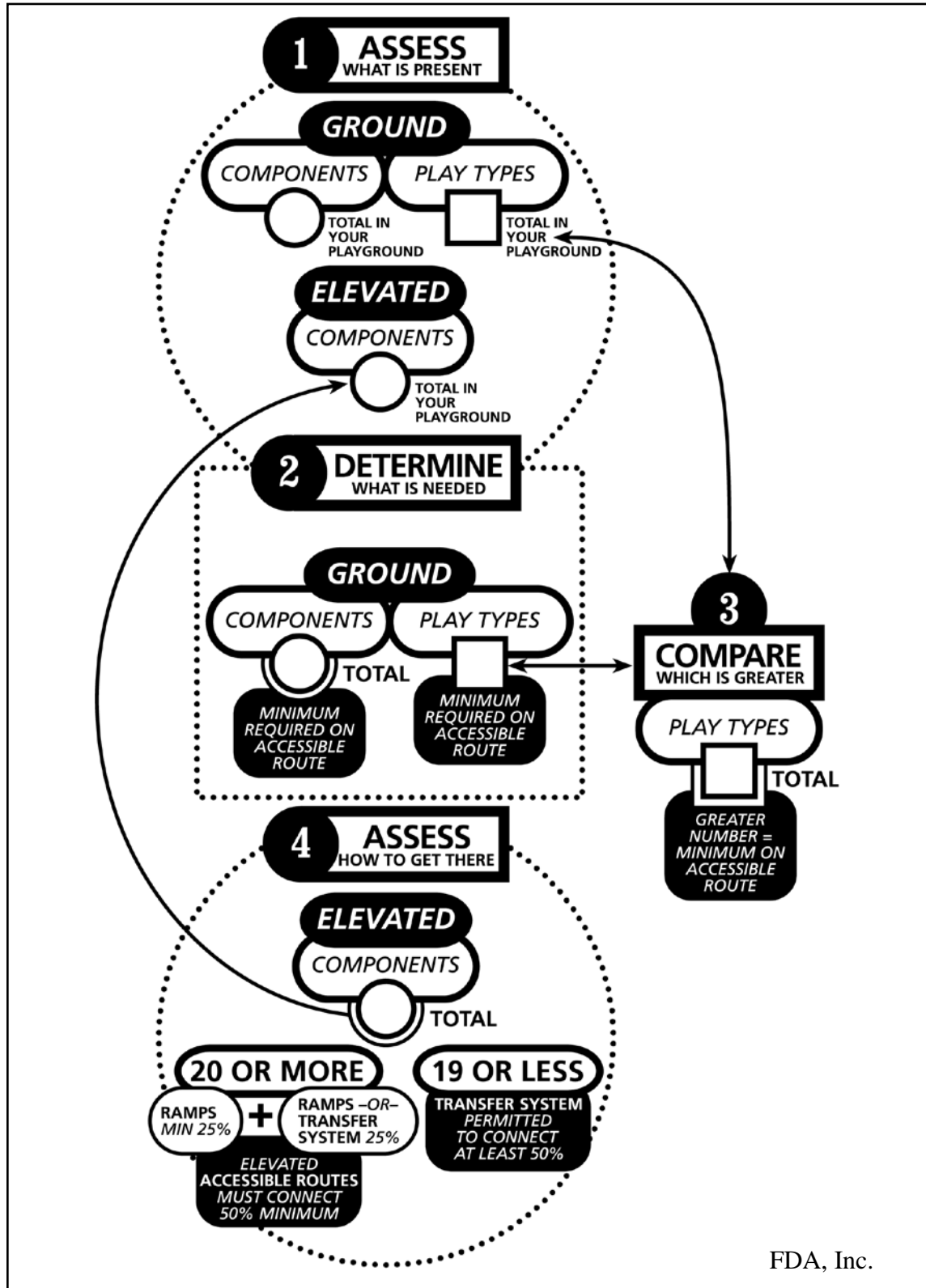

The example below illustrates a proposed design for a new play area. Each section illustrated in the flow chart provides guidelines for the following design tasks:

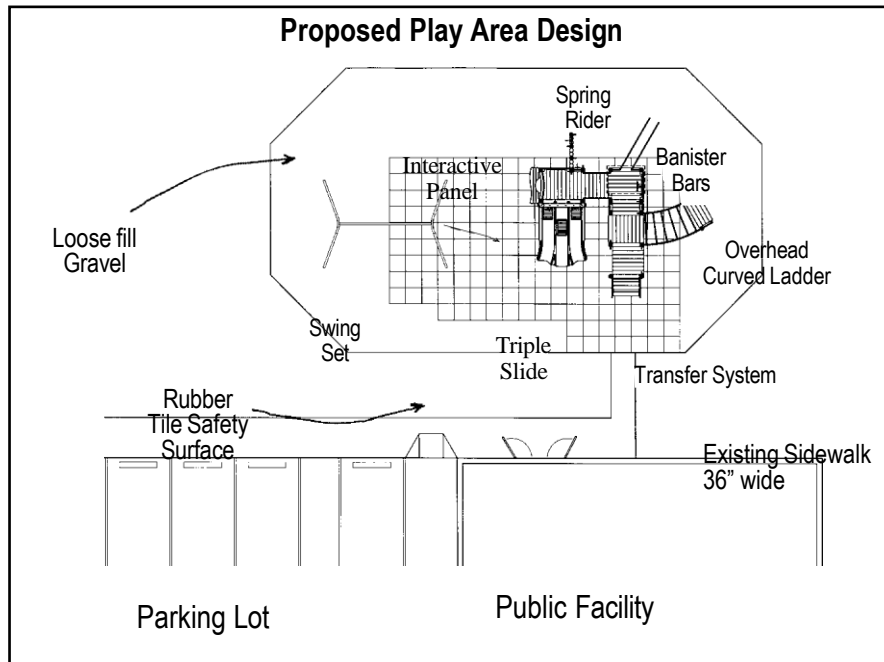

- Determining the number of play components
- Assessing the variety of play types
- Determining how many play components must be on an accessible route
- Determining when ramps are required and when transfer systems are permitted

Refer to this example while reviewing the concepts explained in this guide, to review how accessibility guidelines are applied to play area designs.

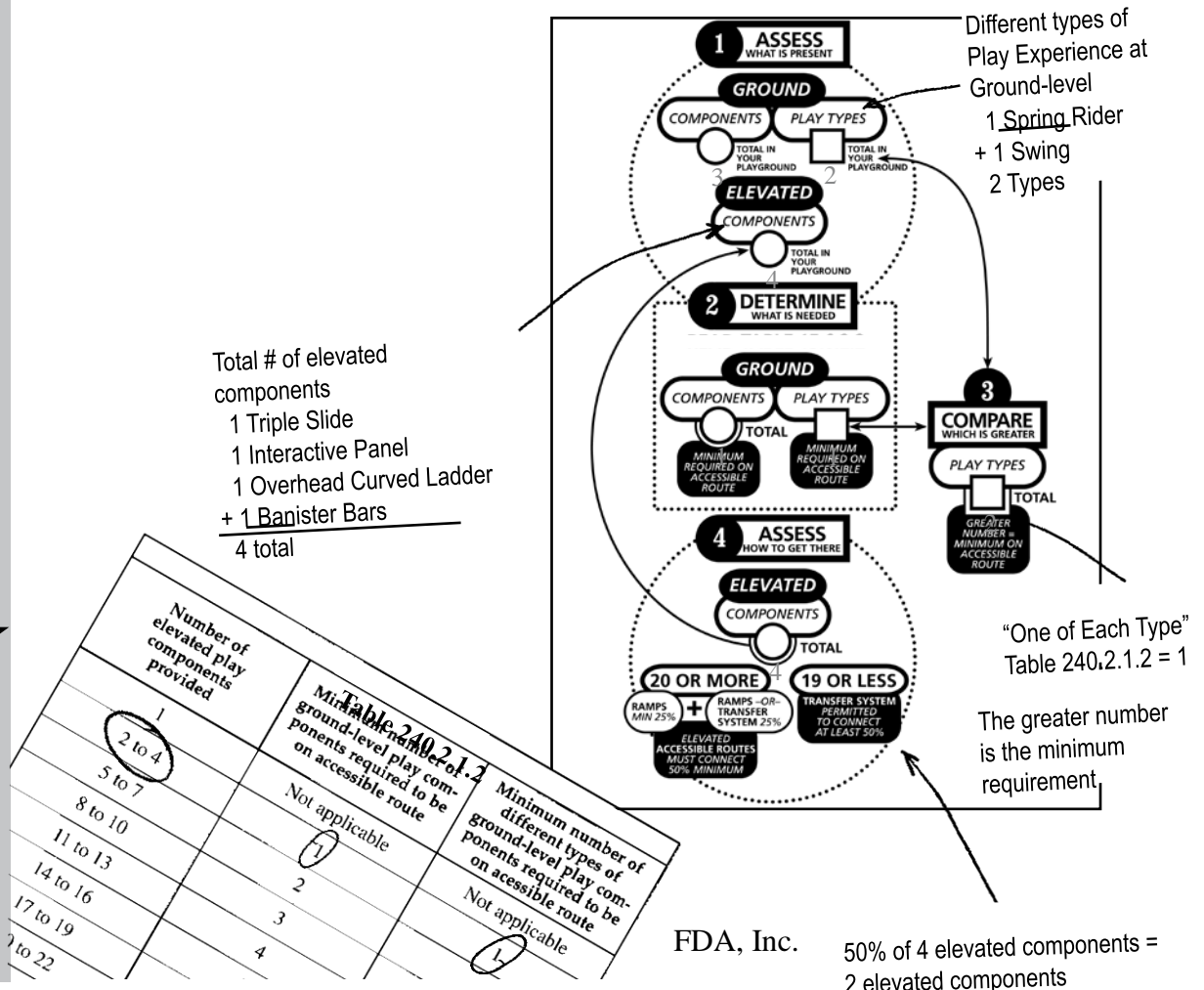

Total # of elevated play components
 1 Triple Slide
 1 Interactive Panel
 1 Overhead Curved Ladder
 + 1 Banister Bars

 4 total

Number of elevated play components provided	Table 240.2.1.2	Minimum number of ground-level play components required to be on accessible route	Minimum number of different types of ground-level play components required to be on accessible route
1	2 to 4	1	Not applicable
2 to 4	5 to 7	2	Not applicable
5 to 7	8 to 10	3	Not applicable
8 to 10	11 to 13	4	Not applicable
11 to 13	14 to 16	Not applicable	Not applicable
14 to 16	17 to 19	Not applicable	Not applicable
17 to 19	20 to 22	Not applicable	Not applicable

WHAT Are the requirements For Accessible routes?

ADAAG chapter 4 addresses accessible routes that connect the play area to the school, parking lot, or facility that it serves. Operators or owners of play areas are subject to all the other requirements of the ADA, including the obligation to provide individuals with disabilities an equal opportunity to enjoy the play area provided by that facility.

This section describes the various features of accessible routes within a play area, including location, clear width, slope, and accessible surfaces.

Accessible routes

An accessible route is a pathway specifically designed to provide access for individuals with disabilities, including those using wheelchairs or mobility devices.



Accessible routes inside the boundaries of play areas are addressed in the play area guidelines. Technical provisions address the width, slope, and surface of both ground-level and elevated accessible routes.

There are two types of accessible routes:

- Ground-level
- Elevated



This ground-level route connects ground components and the transfer system which connects elevated components.

This elevated route connects elevated play components on a composite structure.



The accessible route must connect all entry and exit points of accessible play components.

Clear floor space required at play components and maneuvering space can overlap the accessible route.

Incorporating additional circulation space around high-use play components creates extra room for movement and accessibility for everyone using the play area.



U.S. Access Board
A Summary of Accessibility
Guidelines for Play Areas

Ground-level Accessible routes

The 80-inch vertical clearance applies to ground-level routes only, and not elevated routes. This allows features like protective roofs and sun shelters to be present.

A ground-level accessible route connects play components at ground level.

- 60 inches (1525 mm) minimum clear width
- 1:16 maximum slope

The route may narrow down to 36 inches (915 mm) for a distance of 60 inches (1525 mm). This permits flexibility to work around site design features like existing equipment or trees.

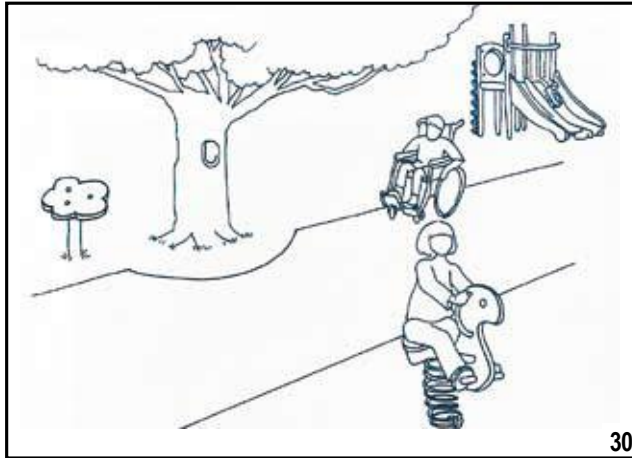

30

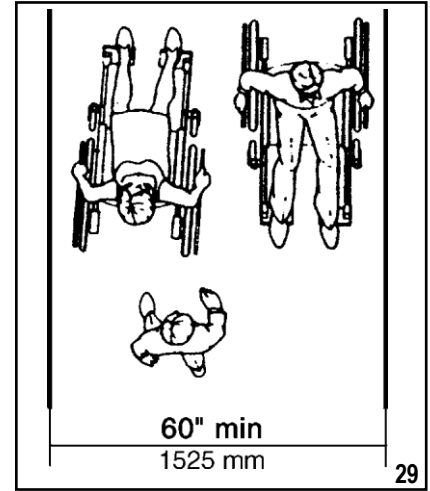

The required 60-inch width enables two wheelchairs to pass each other or to change direction.

Smaller play areas - those that are less than 1,000 square feet (93 square meters) - may have ground-level accessible routes that are 44 inches (1120 mm) clear width. A wheelchair turning space must be provided where the route exceeds 30 feet (9.14 mm) in length.

At ground level, objects may not protrude into the 60-inch wide space of an accessible route up to or below the height of 80 inches (2030 mm), measured above the accessible route surface. The 80-inch clearance applies only to the 60-inch accessible route, and is not required for the entire play area.

The play area provides a fun accessible roadway theme. The protective shelters for the benches have been set outside the boundary of the route providing the 80 inches of clearance required on the route.



31



U.S. Access Board
A Summary of Accessibility
Guidelines for Play Areas

Ground-level Accessible routes

Maximum Slope at Ground level

The maximum allowable slope for a ground-level accessible route is 1:16.

Berms are sometimes used to provide access to elevated play areas. A berm may be a natural sloped surface that is present in a hilly play area site, or a ground-level route built with slopes.

Designers are encouraged to consider edge protection and handrails on berms where there may be a drop-off. Remember the maximum slope of this “ground-level accessible route” is 1:16.

However, handrails are not required on ground-level accessible routes. This is permitted since the handrails may become a safety hazard in the “use zone.”



This play area provides a bermed accessible route.



To accommodate a height change along the perimeter of a play area - like these rubber safety tiles placed on an asphalt surface - an allowable 1:12 slope is utilized for the transition at the boundary of the play area.

Accessible Ground Surfaces

The “use zone” is a ground level area beneath and immediately adjacent to a play structure or piece of equipment that is designated for unrestricted circulation around the equipment. It is predicted that a user would fall and land or exit the equipment on the surface of the use zone.

The American Society for Testing and Materials (ASTM) has established safety standards for play areas, including resilient surfaces. For further information or to purchase these standards, contact ASTM, 100 Barr Harbor Drive, West Conshohocken, PA 19428-2959, www.astm.org.

Ground surfaces along accessible routes, clear floor or ground spaces, and maneuvering spaces, must comply with the American Society for Testing and Materials (ASTM) F 1951- 99 *Standard Specification for Determination of Accessibility to Surface Systems Under and Around Playground Equipment*.

This standard assesses the accessibility of a surface by measuring the work an individual must exert to propel a wheelchair across the surface. The standard includes tests of effort for both straight-ahead and turning movements, using a force wheel on a rehabilitation wheelchair as the measuring device. To meet the standard, the force required must be less than that which is required to propel the wheelchair up a ramp with a slope of 1:14.

When selecting ground surfaces, operators should request information about compliance with the ASTM F 1292-04 standard.



Accessible surfaces can include impact-attenuating tiles made of recycled rubber and engineered wood fiber that meet the ASTM requirements for accessibility and safety. The design can be created so safety is not compromised for individuals using the play area where both standards are applied.

Accessible Surfaces located In the use Zone

If located within the use zone, accessible ground surfaces must also be impact attenuating and meet ASTM F 1292-04 Standard Specification for Impact Attenuation of Surface Systems Under and Around Playground Equipment.

WHAT Are the requireMents For Accessible routes?



Accessible and non-accessible surfaces can be combined to provide variety and excitement in the play area.



Rubber surfacing tiles facilitate access in this play area.

Ground surfaces must be inspected and maintained regularly and frequently to ensure continued compliance with the ASTM F 1292-04 standard. The frequency of maintenance and inspection of resilient surfacing depends on the amount of use and the type of surfacing installed.



Accessible surfacing can be designed to complement the theme of the play area, while providing full access and visually integrating the surface into the overall design. Individuals of all abilities will enjoy the added benefits of an imaginative design.

Engineered wood fiber surfaces will require frequent maintenance to comply with the ASTM F 1292-04 standard because of surface displacement due to user activity or other factors.

Designers and operators are likely to choose materials that best serve the needs of each play area. The type of material selected will affect the frequency and cost of maintenance.



At the time of this publication, rubber surfacing and some engineered wood fiber products meet the ASTM F 1951-99 standard. The fact that a specific product meets the ASTM 1951-99 standard does not necessarily mean that all other similar products will meet the standard.

Operators interested in selecting surfaces to comply with the play area guidelines, should consult individual product manufacturers to determine compliance with ASTM F 1951-99.

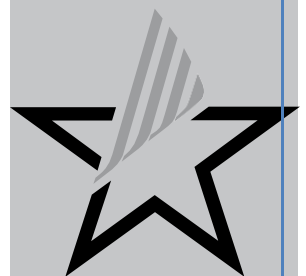

elevated Accessible routes

“Ramps” serve as a continuation of the accessible route from the ground allowing individuals who use mobility devices to access elevated components. The guidelines require that play areas containing 20 or more elevated play components provide ramp access to at least 25 percent of those elevated components.

An elevated accessible route is the path used for connecting elevated play components.

Elevated accessible routes must connect the entry and exit points of at least 50 percent of the elevated play components provided in the play area.

Two common methods for providing access to elevated play components are ramps and transfer systems. Ramps are the preferred method since not all children who use wheelchairs or other mobility devices may be able to use - or may choose not to use - transfer systems.



This photo illustrates an elevated accessible route:

- 36-inch (915 mm) clear width
- 32-inch (815 mm) narrowed width permitted for 24-inch (610 mm) length to accommodate features in the composite structure
- 12-inch (305 mm) rise maximum per ramp run
- Top of handrail gripping surfaces shall be 20 inches (510 mm) minimum to 28 inches (710 mm) maximum above the ramp surface



FDA, Inc.

The 80-inch vertical clearance height does not apply to elevated accessible routes. This allows for the use of features such as roofs and sun shelters.



WHAT Are the requireMentS For Accessible routeS?

When ramps Are required

Ramps are required on composite structures with 20 or more elevated play components and must connect to at least 25% of the elevated play components.

Ramps allow individuals who use wheelchairs and mobility devices to access elevated play components in composite play structures without transferring.



This play area has more than 20 play components and provides ramp access to elevated play components. The ramp system, consisting of ramp runs and landings, must connect at least 25 percent of the elevated play components. The balance of the elevated play components required to be on an accessible route may be connected by the ramp system, or by a transfer system.

Rise of a ramp is the amount of vertical distance the inclined or slanted surface ascends or descends. A ramp **run** is a length of a continuous sloped surface that is ascending or descending. For example, to reach a 12-inch high deck or platform, a designer could use a 12-foot ramp with the maximum 1:12 slope, or a 14-foot ramp with a less steeper 1:14 slope.

Platform lifts, also known as “wheelchair lifts,” may be considered for providing access to elevated play components when appropriate.

Where applicable, platform lifts complying with ADA/ABA Accessibility Guidelines chapter 4 and applicable state and local codes are permitted as a part of an accessible route. Because lifts must be independently operable, owners and operators should carefully consider the appropriateness of their use in unsupervised settings.

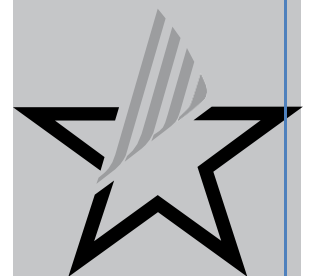

U.S. Access Board
A Summary of Accessibility
Guidelines for Play Areas

“Ramps” are sloped surfaces that provide individuals who use mobility devices with access to elevated components.

ramps

For each elevated ramp run:

- 12-inch (305 mm) maximum rise
- 1:12 maximum slope
- 36-inch (915 mm) minimum clear width



landings

Landings are the level surfaces at the top and bottom of each ramp run.

- Must be as wide as the ramp they connect to
- A minimum length of 60-inches (1525 mm)
- If ramps change direction, the minimum landing size must be 60 inches (1525 mm) wide to accommodate a turn

Maneuvering Space Where ramps are Provided

At least one maneuvering space must be provided on the same level as the play component. The space must have a slope no steeper than 1:48 in all directions (see page 34 for further details).

ADA/ABA Accessibility Guidelines addresses additional requirements for ramps and landings including edge protection, cross slope, surfaces, and outdoor conditions.



Handrails

Handrails are required on both sides of ramps connecting elevated play components. Handrails must comply with the following:

- Clearance between handrail gripping surfaces and adjacent surfaces and shall not be 1 1/2 inches (38mm) minimum.
- Handrail gripping surfaces shall be continuous along their length and shall not be obstructed along their tops or sides. The bottoms of handrail gripping surfaces shall not be obstructed for more than 20 percent of their length. Where provided, horizontal projections shall occur 1 1/2 inches (38mm) minimum below the bottom of the handrail gripping surface.



In this case, additional handrails have been provided.

Handrails are required to comply with ADA/ABA 505. However, extensions on handrails in the play area are not required. This is to prevent children running into protruding rails in the play area.

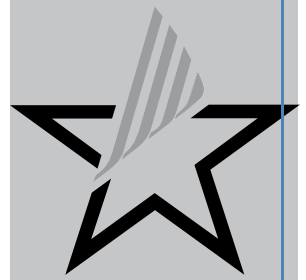

U.S. Access Board
A Summary of Accessibility
Guidelines for Play Areas

When transfer Systems Are used

A “transfer system” is an alternative to a ramp system in play areas where there are less than 20 total elevated play components.

The transfer system must connect to the ground-level accessible route and provide access to at least 50 percent of the elevated play components.

A transfer system provides access to elevated play components within a composite system by connecting different levels with transfer platforms and steps.

A transfer system provides access to elevated play components without the use of a wheelchair or mobility device. At least 50% of the elevated play components can be connected by a transfer system in play areas with less than 20 elevated components. In play areas with 20 or more elevated play components, transfer systems may be used to connect up to 25% of the elevated play components and the rest of the elevated play components required to be on an accessible route must be connected by a ramp.



A transfer system typically consists of a transfer platform, transfer steps, and transfer supports.

Where a transfer system is provided, a combination of transfer platforms and transfer steps provide a continuous accessible route to elevated play components. A transfer system provides individuals the space necessary to physically transfer up or down in a composite play structure. Where provided, a 24-inch (610 mm) minimum width is necessary for individuals moving around a structure.



Playful features can be part of the transfer system, providing interactive experiences from both an elevated or ground level approach.

Consider the distance someone must travel to reach play components accessed by transfer systems. On page 31, the illustration shows a transfer system placed directly next to the slide. Access to this type of elevated play component has been carefully designed to minimize the distance someone must transfer to reach it.

FDA, Inc.

WHAT Are the requirements For Accessible routes?

transfer Platforms

A transfer platform is a platform or landing that an individual who uses a wheelchair or mobility device can use to lift or transfer onto the play structure and leave the wheelchair or mobility device behind at ground-level.



- 11 inches (280 mm) to 18 inches (455 mm) height of top surface
- Minimum 24 inches (610 mm) wide
- Minimum 14 inches (355 mm) deep
- Unobstructed side

Adding a transfer step that leads to the ground's surface increases access for children exiting components at the ground level.

Transfer steps in a play area are not required to satisfy the general ADAAG stair requirements.

Maneuvering space and clear space is not required on elevated structures or at elevated play components reached by a transfer system.

Clear floor or ground space - used for parking wheelchair or mobility devices (commonly called “wheelchair parking”) - is required at the transfer platform.

The 48-inch long side (1200 mm) of the “wheelchair parking” space must be parallel to the 24-inch (610 mm) side of the transfer platform.

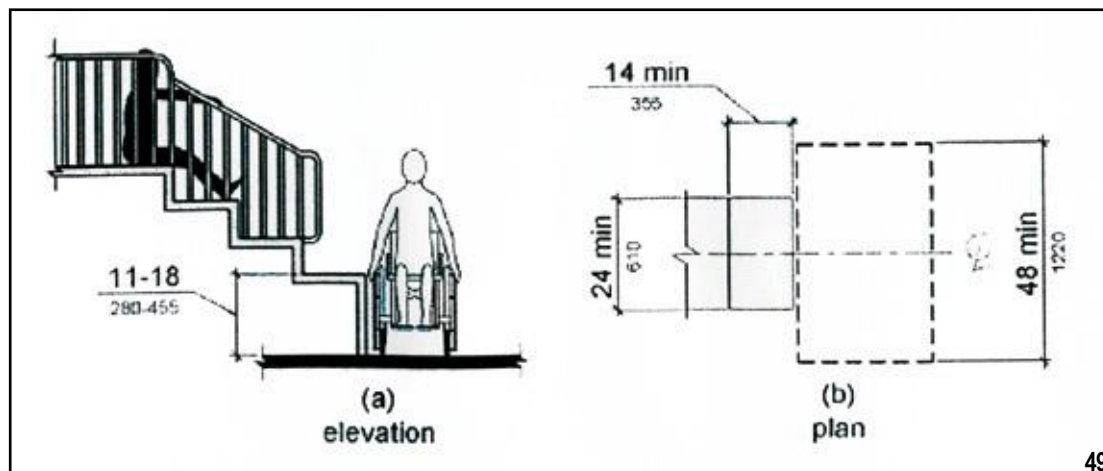

49



U.S. Access Board
A Summary of Accessibility
Guidelines for Play Areas

Transfer steps are level surfaces in a composite structure that can be used for transferring from different levels to access play components.

transfer Steps

- Minimum 24 inches (610 mm) wide
- Minimum 14 inches (355 mm) deep
- 8 inches (205 mm) maximum height

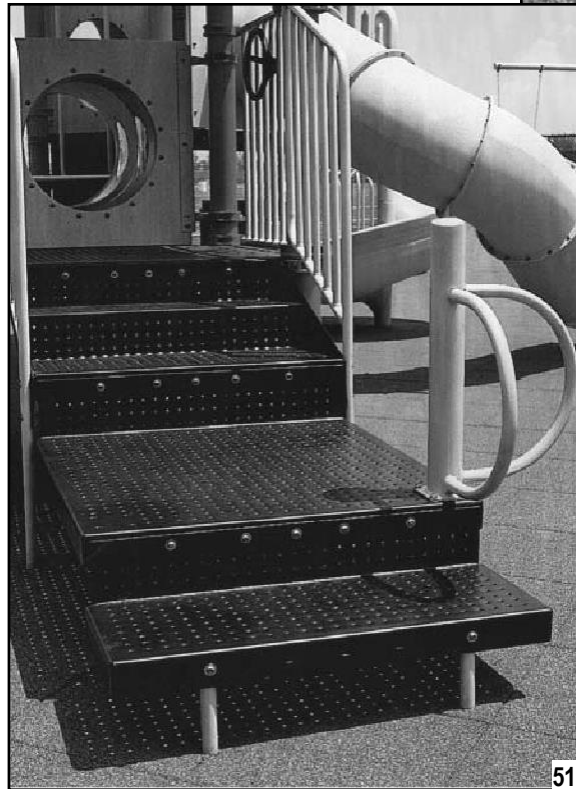

Play areas intended for smaller children should provide steps at smaller height increments. This will accommodate smaller sized children who must lift or “bump” up each step.



WHAT Are the requireMents For Accessible routes?

transfer Supports

Transfer supports must be provided on transfer platforms and transfer steps at each level where transferring is the intended method of access.

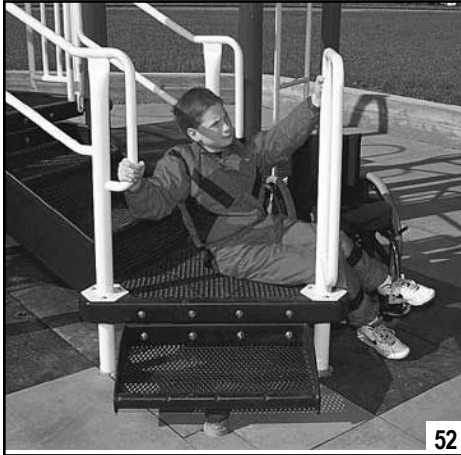

Materials in a variety of different shapes and sizes are used to manufacture transfer supports including metal, plastic, and rope.

A means of support is required when transferring into the entry or seat of a play component.

Transfer supports assist individuals with transferring and general mobility. They include handrails, handgrips, or custom designed handholds.



Aesthetically pleasing cut-out shapes and other design enhancements can provide hand supports for transferring.

Consideration must be given to the distance between the transfer system and the elevated play components it is intended to facilitate. Designers should minimize the distance between the point where a child transfers from a wheelchair or mobility device and the elevated play destination.

This transfer system provides access to exciting elevated play experiences like sliding while minimizing the distance individuals must traverse.

FDA, Inc.

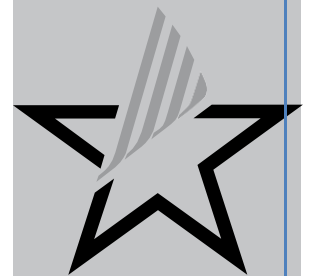
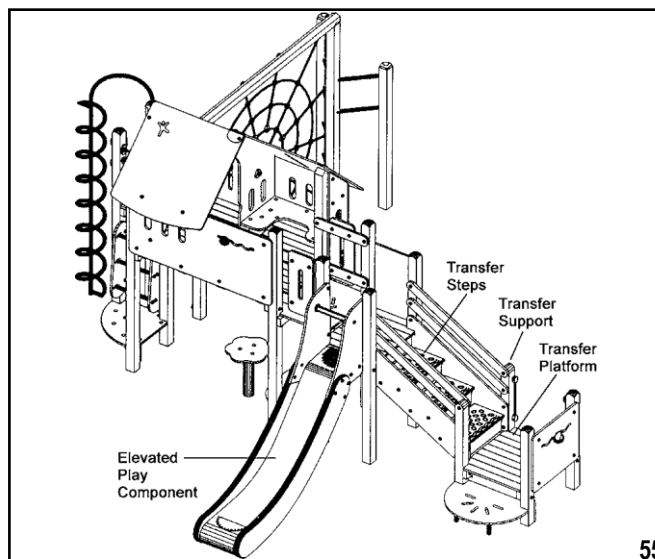

U.S. Access Board
A Summary of Accessibility
Guidelines for Play Areas

connected elevated components

Elevated play components that are connected to other play components count toward fulfilling the requirement for the number of elevated components on an accessible route where transfer systems are used.

When transfer systems are used, an elevated play component may connect to other elevated play components, providing an innovative, accessible route.

A crawl tube is an elevated play component in this composite structure. Going through the tunnel provides access to additional activities on the other side.



56

Consideration should be given to how a play component is utilized when it is selected to connect to other elevated play events. When a transfer system is provided, children move through a play component like this crawling tube, using their own strength without a mobility device.



57

Providing variety and excitement through elevated play spaces benefits all children. Tunnels and tubes make “getting there” an activity in itself.

FDA, Inc.

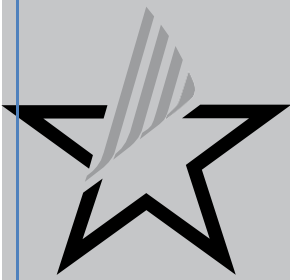

U.S. Access Board
A Summary of Accessibility
Guidelines for Play Areas

The play area guidelines address accessible routes connecting play components along with certain spaces that are crucial to making a play area usable for children with disabilities. The other requirements for play components are provided to promote general usability, with application to a variety of play components. Additional features will assist in making play components more accessible to more children. Designers are encouraged to consider components with back support, increased space for maneuvering adjacent to the play component, and other features that promote independent use.

clear Floor or Ground Space

Clear floor space - also known as ground space - provides unobstructed room to accommodate a single stationary wheelchair and its occupant at a play component on an accessible route.

- 30-inch (760 mm) by 48-inch (1220 mm) minimum area
- May overlap accessible routes and maneuvering spaces
- Slope not steeper than 1:48 in all directions



The clear floor space is permitted to overlap onto the landing area to provide access to this elevated window activity.

Play components come in a variety of shapes and sizes facilitating a broad range of experiences. A specific location for clear floor or ground space has not been designated. Each play component is unique and the spaces must be placed in the best location for the situation.

This interactive play component has a clear ground space that allows front or side reach interaction.



Elevated play components accessed by transfer systems do not require maneuvering or clear floor spaces, since mobility devices are left at ground level.

Clear floor or ground space is also sometimes called "wheelchair parking space."

The minimum clear floor or ground space on a composite structure may be positioned for a forward or parallel approach. It may overlap accessible routes and maneuvering spaces.



U.S. Access Board
A Summary of Accessibility
Guidelines for Play Areas

Maneuvering Space

Maneuvering space is defined as the space required for a wheelchair to make a 180-degree turn. At least one maneuvering space must be provided on the same level as elevated play components.

When providing access to ground level and elevated play components by ramps, space allowances to accommodate wheelchairs and mobility devices are required.

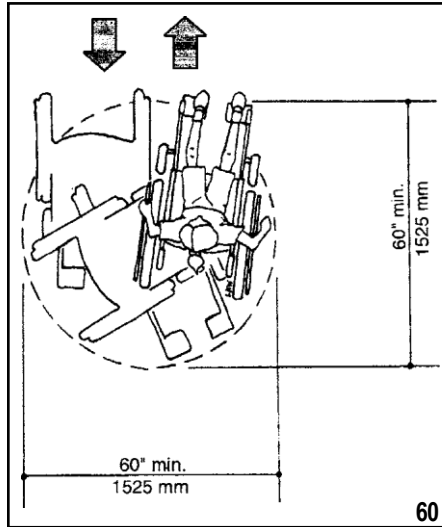

- A 60-inch (1525 mm) turning circle permits individuals with mobility devices to turn around
- A 60-inch (1525 mm) T-Shaped turn allows an individual to change directions by making a series of multi-point turns
- Slope not steeper than 1:48 in all directions

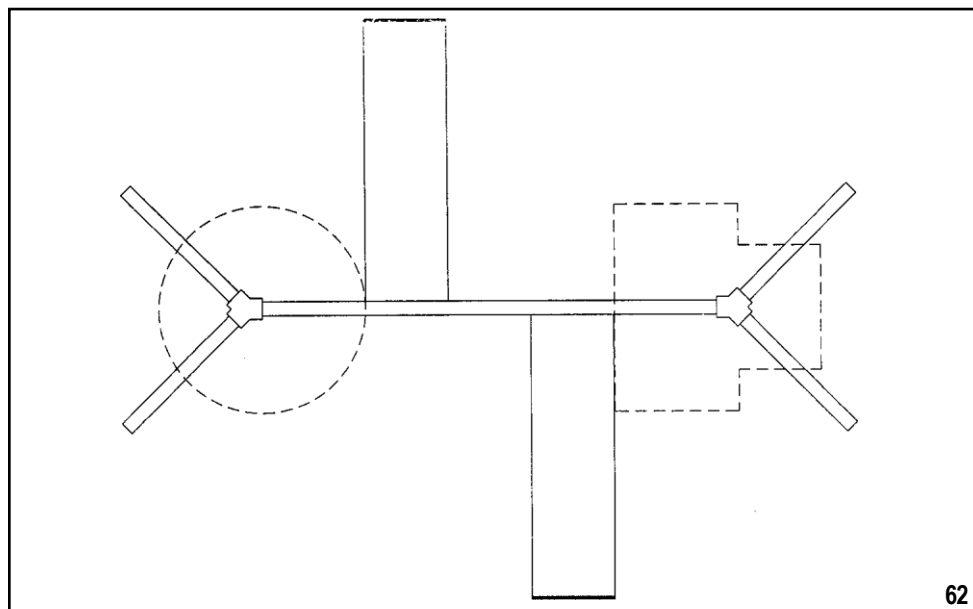
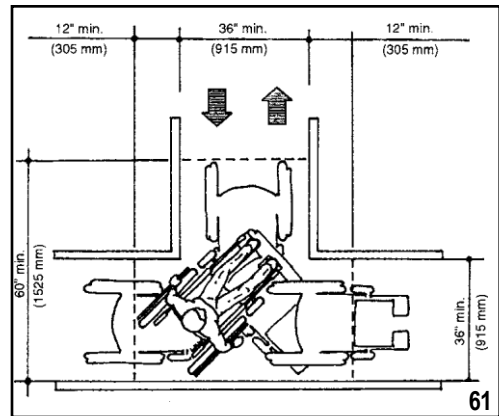

Maneuvering space is required for swings and must be located adjacent to the swing. This illustration shows options for either a 60-inch turning circle or a T-shaped turn. While this illustration shows the maneuvering space to the side of the swing, the space may be located behind or in front of the swing as long as it is immediately adjacent to the swing.

Objects are not permitted to protrude into ground level maneuvering spaces at or below 80 inches (2030 mm) above the ground or floor surface.

entry Points and Seats

Entry points and seats are features of play components where individuals would transfer, sit, or gain access. When play components are located on an accessible route, the height required to transfer directly to the entry point or seat of a play component has a minimum of 11 inches (280 mm) and a maximum of 24 inches (610 mm). A mid-level height of 18 inches (455 mm) is recommended.

The height of the entry point of a slide is not specified.



Examples of entry points and seats include swing seats, spring rocker seats, and crawl-tube openings.



Consider design features like open sides, back supports, and hand supports to help facilitate easy transfer and access.



U.S. Access Board
A Summary of Accessibility
Guidelines for Play Areas

Play tables

Play tables may be located at a ground or elevated level in a composite play structure. Consider the route, clear floor space and maneuvering spaces for tables intended to be accessible to individuals who use wheelchairs.

Play tables are surfaces, boards, slabs, or counters that are created for play. This includes tables designed for sand and water play, gathering areas, and other activities. Where play tables are located on an accessible route, the wheelchair knee clearance minimums are:

- 24 inches (610 mm) high minimum
- 30 inches (760 mm) wide minimum
- 17 inches (430 mm) deep minimum



67



68

Play tables designed primarily for children under 5-years-old, may provide a parallel approach instead of knee clearance if the rim is a maximum of 31 inches (785 mm) high.

The edge of this elevated sand table has been designed to provide access by providing a generous opening. The tops of rims, curbs, or other obstructions that would prevent access to a table surface should be 31 inches (785 mm) maximum in height.



69

Reach ranges are the recommended designated regions of space that a person seated in a wheelchair can reasonably extend their arm or hand to touch, manipulate, move, or interact with an object or play component.

Reach ranges should be considered when providing play components with manipulative or interactive features for children who use wheelchairs. Recommended forward or side reach ranges are:

- 20 to 36 inches for 3 to 4 year-olds
- 18 to 40 inches for 5 to 8 year-olds
- 16 to 44 inches for 9 to 12 year-olds

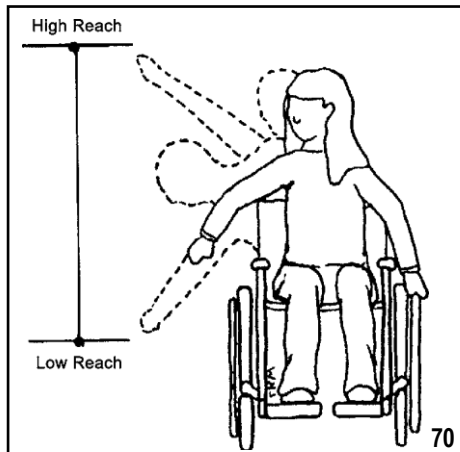

Side Reach

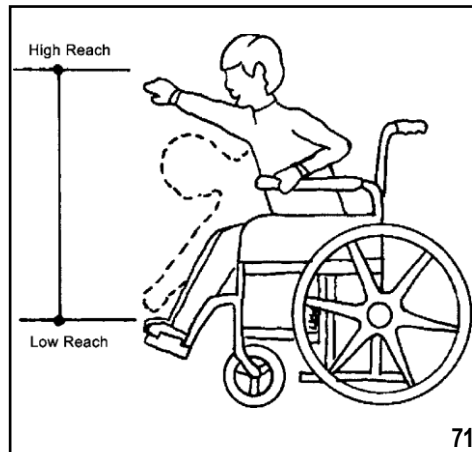

Forward Reach

The reach ranges appropriate for use by children who use wheelchairs to access play components are intended for ground-level components, and elevated components accessed by ramps. Reach ranges are not appropriate for play components reached by transfer systems.



Appropriate reach range heights will vary depending on how the play component is accessed. This interactive panel is mounted at a height appropriate for a child who uses a wheelchair.

The reach ranges in this guide are recommendations that should be considered when designing play components with manipulative features intended for use by individuals who use wheelchairs.

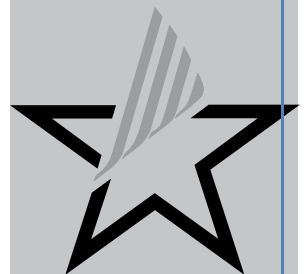

U.S. Access Board
A Summary of Accessibility
Guidelines for Play Areas

“Soft contained play equipment” is a play structure made of one or more components, on which an individual enters a fully enclosed play environment that uses pliable materials such as plastic, soft padding, and fabric.

Soft contained play structures must provide at least one entry point on an accessible route when three or fewer entry points are provided.

If four or more entry points are provided, at least two entry points must be located on an accessible route.

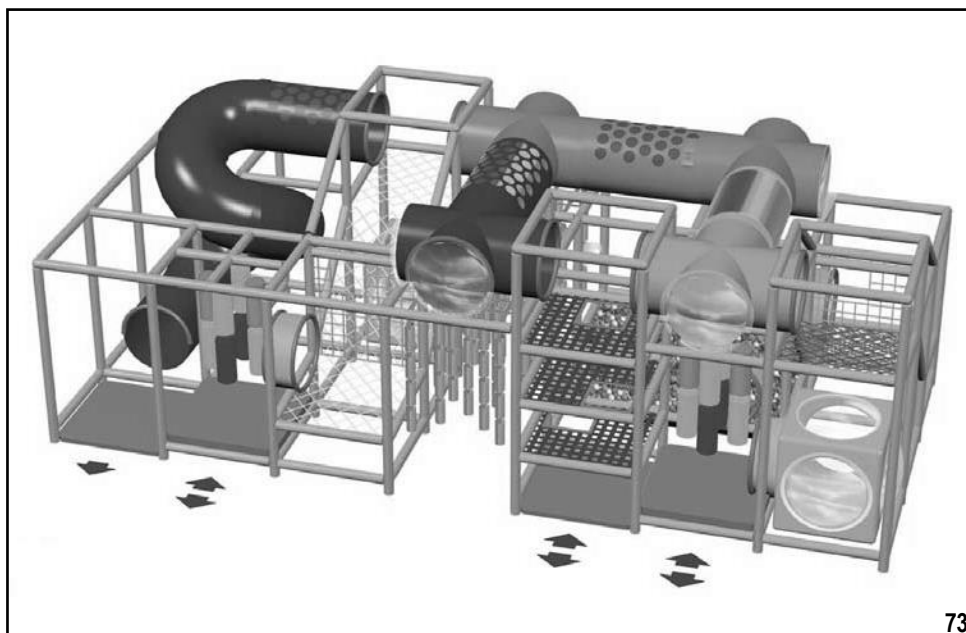

Soft contained play environments typically have limited entrance and exit locations, with play components integrated into the system design.



Transfer systems or platform lifts can serve as a part of an accessible route connecting entry points on soft-contained play structures.



U.S. Access Board
A Summary of Accessibility
Guidelines for Play Areas

The play area guidelines apply to alterations made to existing play areas that affect, or could affect, the usability of the play area. Examples include removing a climbing play component and replacing it with a spring rocker, or changing the ground surfacing.

Alterations provide an opportunity to improve access to existing play areas. Where play components are altered and the ground surface is not, the ground surface does not have to comply with the ASTM F 1951-99 standard for accessible surfaces unless the cost of providing an accessible surface is less than 20 percent of the cost of the alterations to the play components.

If the entire ground surface of an existing play area is replaced, the new ground surface must provide an accessible route to connect the required number and types of play components. The requirements for accessible routes are explained on page 19.



This play area was altered by adding two spring rockers. The seat of at least one spring rocker is between 11 inches (280mm) and 24 inches (610mm) maximum, and clear floor or ground space and maneuvering space is provided. If the ground surface is replaced in the future, an accessible route would have to be provided to the spring rocker.

Normal maintenance activities such as replacing worn ropes or topping off ground surfaces are not considered alterations.

If play components are relocated in an existing play area to create safe use zones, the guidelines do not apply, provided that the ground surface is not changed or extended for more than one use zone.

Replacing the entire ground surface does not require the addition of more play components.

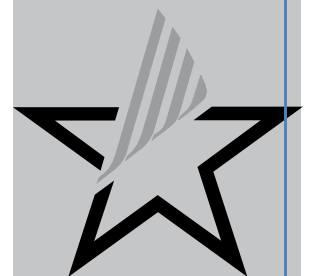

U.S. Access Board
A Summary of Accessibility
Guidelines for Play Areas

The Access Board would like to thank the following manufacturers for their generous assistance and for supplying appropriate photographs or illustrations: Bob Leathers, Columbia Cascade, GameTime, KOMPAN, Landscape Structures, Little Tikes, Miracle, Olympic Recreation, Playworld Systems, and Recreation Creations.

The numerical listing below shows the source of each photo or illustration.

- | | |
|------------------------------|--------------------------|
| Top Cover Photo - KOMPAN | 38. KOMPAN |
| Bottom Cover Photo - Miracle | 39. KOMPAN |
| 1. KOMPAN | 40. GameTime |
| 2. Little Tikes | 41. GameTime |
| 3. KOMPAN | 42. GameTime |
| 4. KOMPAN | 43. Playworld Systems |
| 5. KOMPAN | 44. Landscape Structures |
| 6. Little Tikes | 45. Miracle |
| 7. KOMPAN | 46. Landscape Structures |
| 8. Little Tikes | 47. Little Tikes |
| 9. KOMPAN | 48. Landscape Structures |
| 10. KOMPAN | 49. KOMPAN |
| 11. Landscape Structures | 50. Game Time |
| 12. Miracle | 51. Recreation Creations |
| 13. KOMPAN | 52. Miracle |
| 14. Little Tikes | 53. KOMPAN |
| 15. GameTime | 54. Playworld Systems |
| 16. Playworld Systems | 55. KOMPAN |
| 17. GameTime | 56. KOMPAN |
| 18. Little Tikes | 57. KOMPAN |
| 19. Landscape Structures | 58. Olympic Recreation |
| 20. Miracle | 59. Playworld Systems |
| 21. Recreation Creations | 60. KOMPAN |
| 22. Miracle | 61. KOMPAN |
| 23. Miracle | 62. Access Board |
| 24. Landscape Structures | 63. Playworld Systems |
| 25. Miracle | 64. Little Tikes |
| 26. Columbia Cascade | 65. Landscape Structures |
| 27. Playworld Systems | 66. GameTime |
| 28. GameTime | 67. Playworld Systems |
| 29. KOMPAN | 68. Landscape Structures |
| 30. Elizabeth Garufi | 69. Bob Leathers |
| 31. Little Tikes | 70. KOMPAN |
| 32. Playworld Systems | 71. KOMPAN |
| 33. KOMPAN | 72. Miracle |
| 34. Columbia Cascade | 73. GameTime |
| 35. KOMPAN | 74. Access Board |
| 36. KOMPAN | 75. Miracle |
| 37. Little Tikes | |





amusement rides boating facilities fishing piers & platforms golf courses miniature golf sports facilities swimming pools & spa

accessible amusement rides

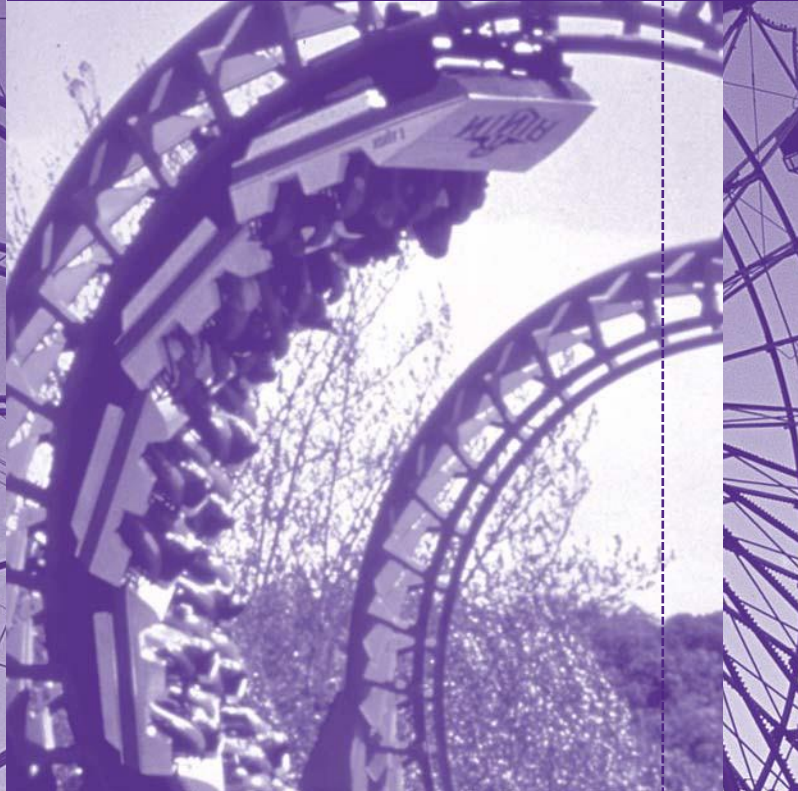

a summary of
accessibility guidelines
for recreation facilities

JUNE 2003

FDA, Inc.

Contents

Accessibility Guidelines for Recreation Facilities . . .	128
Introduction	128
Amusement Rides	131
Exceptions	132
Unique Attractions	133
Accessible Rides	133
Accessible Routes	133
Signage	135
Amusement Rides with Wheelchair Spaces	135
Amusement Ride Seats Designed for Transfer	139
Transfer Devices for Use with an Amusement Ride	141
Wheelchair Storage Space	142
More Information	142

This information has been developed and reviewed in accordance with the Access Board's information quality guidelines (www.access-board.gov/infoquality.htm).

Accessibility Guidelines for Recreation Facilities



Introduction

The Americans with Disabilities Act (ADA) is a comprehensive civil rights law that prohibits discrimination on the basis of disability. The ADA requires that newly constructed and altered state and local government facilities, places of public accommodation,

and commercial facilities be readily accessible to, and usable by, individuals with disabilities.

The ADA Accessibility Guidelines (ADAAG) is the standard applied to buildings and facilities. Recreational facilities, including amusement park rides, are among the facilities required to comply with the ADA.

The Access Board issued accessibility guidelines for newly constructed and altered recreation facilities in 2002. The recreation facility guidelines are a supplement to ADAAG. As a supplement, they must be used in conjunction with ADAAG. References to ADAAG are mentioned throughout this summary. Copies of ADAAG and the recreation facility accessibility guidelines can be obtained through the Board's website at www.access-board.gov or

by calling 1-800-872-2253 or 1-800-993-2822 (TTY). Once these guidelines are adopted by the Department of Justice (DOJ), all newly designed, constructed and altered recreation facilities covered by the ADA will be required to comply.

The recreation facility guidelines cover the following facilities and elements:

- Amusement rides
- Boating facilities
- Fishing piers and platforms
- Miniature golf courses
- Golf courses
- Exercise equipment
- Bowling lanes
- Shooting facilities
- Swimming pools, wading pools, and spas

This guide is intended to help designers and operators in using the accessibility guidelines for amusement park rides. These guidelines establish minimum accessibility requirements for newly designed or newly constructed and altered amusement park rides. This guide is not a collection of amusement ride designs. Rather, it provides specifications for elements of amusement rides to create a general level of usability for individuals with disabilities. Emphasis is placed on ensuring that individuals with disabilities are generally able to access the amusement ride and use a variety of elements. Designers and operators are encouraged to exceed the guidelines where possible to provide increased accessibility and opportunities. Incorporating accessibility into the design of an amusement ride should begin early in the planning process with careful consideration to accessible routes and providing access to rides.

The recreation facility guidelines were developed with significant public participation. In 1993, the Access Board established an advisory committee of 27 members to recommend accessibility guidelines for recreation facilities. The Recreation Access Advisory Committee represented the following groups and associations:

- American Ski Federation
- American Society for Testing and Materials (Public Playground Safety Committee)
- American Society of Landscape Architects
- Beneficial Designs
- City and County of San Francisco, California, Department of Public Works
- Disabled American Veterans
- Environmental Access
- Golf Course Superintendents Association of America
- Hawaii Disability and Communication Access Board
- International Association of Amusement Parks and Attractions
- Katherine McGuinness and Associates
- Lehman, Smith, and Wiseman Associates
- Michigan Department of Natural Resources
- National Council on Independent Living
- National Park Service
- National Recreation and Park Association
- New Jersey Department of Community Affairs
- Outdoor Amusement Business Association
- Paralyzed Veterans of America
- Professional Golfer's Association
- Self Help for Hard of Hearing People
- States Organization for Boating Access
- Universal Studios
- U.S. Army Corps of Engineers
- U.S. Forest Service
- Y.M.C.A. of the U.S.A.
- Walt Disney Imagineering



The public was given an opportunity to comment on the recommended accessibility guidelines, and the Access Board made changes to the recommended guidelines based on the public comments. A notice of proposed rulemaking (NPRM) was published in the Federal Register in July 1999, followed by a five-month public comment period. Further input from the public was sought in July 2000 when the Access Board published a draft final rule soliciting comment. A final rule was published in September 2002.

“Whenever a door is closed to anyone because of a disability, we must work to open it... Whenever any barrier stands between you and the full rights and dignity of citizenship, we must work to remove it, in the name of simple decency and justice. The promise of the ADA...has enabled people with disabilities to enjoy much greater access to a wide range of affordable travel, recreational opportunities and life-enriching services.”

President George W. Bush, New Freedom Initiative, February 1, 2001

Amusement Rides

The recreation facility guidelines described in this guide focus on newly designed or newly constructed and altered amusement rides. Other provisions contained in ADAAG address elements commonly found at an amusement park or theme park, such as accessible vehicle parking spaces, exterior accessible routes, and toilet and bathing facilities. ADAAG addresses only the built environment (structures and grounds). The guidelines do not address operational issues. Questions regarding operational issues should be directed to the Department of Justice, 1-800-514-0301 or 1-800-514-0383 (TTY).

An “amusement ride” is defined by the guidelines as a system that moves people through a fixed course within a defined area for the purpose of amusement. The guidelines do not apply to vehicles such as trams or gondolas, which, while they may be enjoyable, are designed primarily to transport people. These vehicles are addressed in the ADA Accessibility Guidelines for Transportation Vehicles, which can be found at www.access-board.gov/transit/html/vguide/htm.

New Rides

New rides refer to the “first use,” which is the first time amusement park patrons take a ride on a custom designed or newly manufactured ride. If a ride is moved to another area

of a park or to another park, it is not considered new. If the ride was purchased from another entity, “new” is the first permanent installation of the ride, whether it was purchased “off the shelf” or modified before installation.

Altered Rides

Altered rides refer to changes in structural or operational characteristics of an existing ride vehicle configuration from those specified by the manufacturer or the original design criteria. An existing ride is also considered an altered ride if the load or unload area is newly designed or constructed. Thus, if an existing ride is simply moved to another area of a park or to another park, it is not considered altered unless the load or unload area is newly designed or newly constructed. Routine maintenance, painting, or changing the theme boards is not considered an alteration.



Exceptions

There are four types of rides that are not covered by the guidelines. However, other ADA requirements still apply. The four types are:

- Mobile or portable amusement rides such as those in traveling carnivals, State and county fairs, and festivals, do not need to comply. Mobile rides are available that provide wheelchair access and other rides could provide transfer access with minor modifications.
- Rides that are controlled or operated by the rider (such as bumper cars and go-carts) are not required to comply with the guidelines, but an accessible route to the ride and a turning space (60-inch diameter circle or T-shaped turning space) in the load and unload area must be provided. (This exception does not apply if patrons can merely cause the ride to make incidental movements, but otherwise have no control over the ride.)

- Rides designed for children, assisted on and off by an adult, are only required to provide an accessible route to the ride and a turning space in the load and unload area. While the occasional adult user may ride, the exception applies only to those rides that are designed for children.
- Rides that do not have seats must only provide an accessible route to the load and unload areas and a turning space in the load and unload area.

Unique Attractions

There are amusement attractions that are not specifically addressed by the guidelines, for example, “virtual reality” rides when a device does not move on a fixed course through an area. For these attractions, the guidelines should be applied to the extent possible. An accessible route should be provided to connect to a reasonable number, but at least one, of these attractions. If appropriate technical provisions exist, they should be applied. Operators are still subject to all the other ADA requirements, including program accessibility or barrier removal and the obligation to provide equal opportunities.

Accessible Rides

Each newly constructed or newly designed amusement ride must provide at least one wheelchair space, or at least one ride seat designed for transfer, or a transfer device designed to transfer a person using a wheelchair from the load and unload area to a ride seat. The choice of which type of access that is provided for each ride is left up to the operator or designer.

Where possible, operators are encouraged to exceed the number of accessible ride seats so that more people with disabilities and their families can enjoy the rides at the same time.

Accessible Routes

Accessible routes are continuous, unobstructed paths connecting all accessible elements and spaces of a building or facility. For each accessible amusement ride, an accessible route

is required to connect to a wheelchair space, a ride seat designed for transfer, or a transfer device for use with an amusement ride. The accessible route must comply with ADAAG provisions for the location, width (minimum of 36 inches), passing space, head room, surface, slope (maximum of 1:12 or 8.33%), changes in level, doors, egress, and areas of rescue assistance, unless otherwise modified by specific provisions outlined in this guide.

As previously discussed, an accessible route is also required to connect the load and unload areas of rides that are not required to comply with the guidelines. This includes rides that are controlled by the rider, rides designed for children, and rides without seats.

Any part of an accessible route with a slope greater than 1:20 (5%) is considered a ramp, which limits the slope to 1:12 (8.33%) maximum. There are some exceptions to the accessible route requirements when connecting to an accessible amusement ride:

- In the load and unload areas or on the ride, the guidelines permit slopes as steep as 1:8 (12.5%), if it is structurally or operationally infeasible to limit ramps to slopes of 1:12 (8.33%). In most cases, this will be limited to areas where the route leads directly to

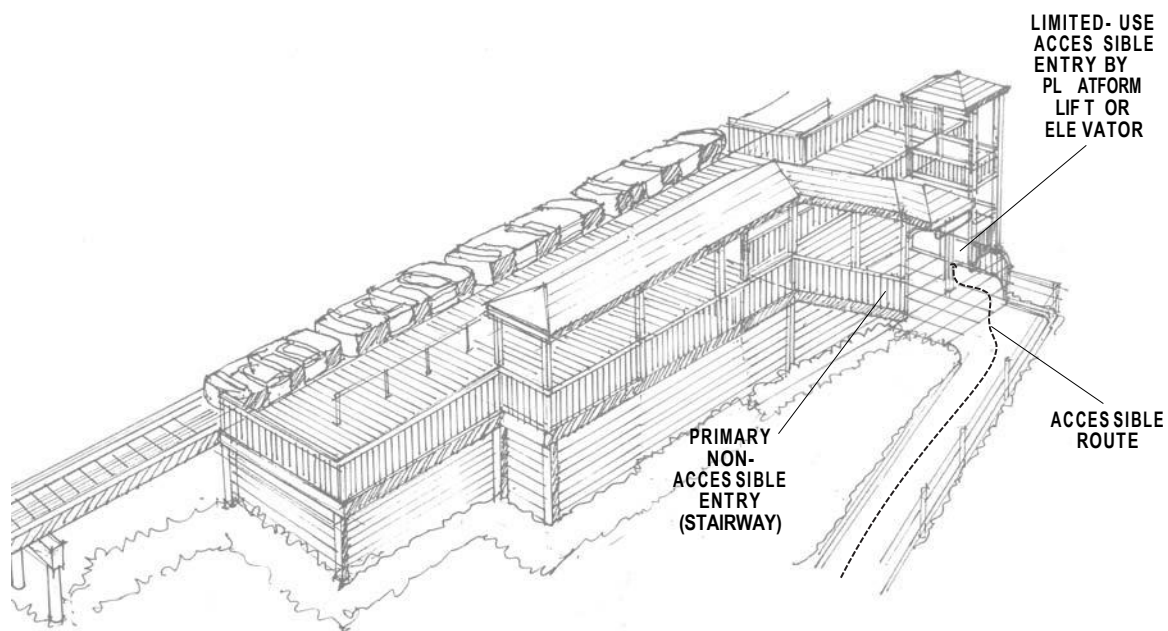

the ride and there are space limitations on the ride. This exception does not apply to the queue line.

- Handrails are not required on accessible routes that exceed 1:20 (5%) in the load and unload area or on the ride, if it is structurally or operationally infeasible to provide them.
- Limited-use/limited-application elevators (LULA's) and platform lifts may be provided as part of the accessible route serving the load and unload area. Platform lifts must comply with ADAAG.

The guidelines do not address the motion or speed of moving turntables and walkways as part of the accessible route because those can be stopped or slowed. Operators should adjust the speed to accommodate riders, where necessary.

Signage

Signage must be provided at the entrance of the queue or waiting line for each accessible amusement ride to identify the type of access provided on the ride (e.g., rides with wheelchair spaces or transfer rides). If the route to the accessible load area is different for persons with disabilities than for other riders, there must be signage indicating the location of the accessible load area so that riders can avoid unnecessary backtracking.

Amusement Rides with Wheelchair Spaces

Minimum space requirements and clearances for wheelchairs are specified where a ride provides a wheelchair space. If possible, designers and manufacturers should incorporate more space to enhance the ease of loading and unloading and to accommodate a greater variety of personal mobility devices.

Approach

Turning space (60-inch diameter or T-shaped space) for a wheelchair must be provided where the accessible route adjoins the ride, so that riders can access the ride. One side

of the wheelchair space must adjoin an accessible route. The turning space may overlap the accessible route and the required clear floor space.

Load and Unload Areas

The floor or ground surface in the load and unload areas must have a slope not steeper than 1:48 and be stable, firm, and slip resistant.

Gaps

Where wheelchair spaces are provided on amusement rides, the floors of rides must be coordinated with the floors of the load and unload areas so that when the ride is at the load and unload position, the vertical differences between the two floors are within 5/8 inch and the horizontal gap is not more than 3 inches, under normal conditions.

However, if compliance with those measurements is not operationally or structurally feasible, operators may use bridge plates, ramps or other devices. They must comply with the Board's vehicle guidelines (36 CFR 1192.83 (c), available at www.access-board.gov/transit/html/vguide.htm#LRVM).

Clearances

Wheelchair spaces on amusement rides must comply with the following provisions, with three exceptions:

- Securement devices may overlap required clearances.
- The wheelchair spaces may be mechanically or manually repositioned, for example, using a turntable.

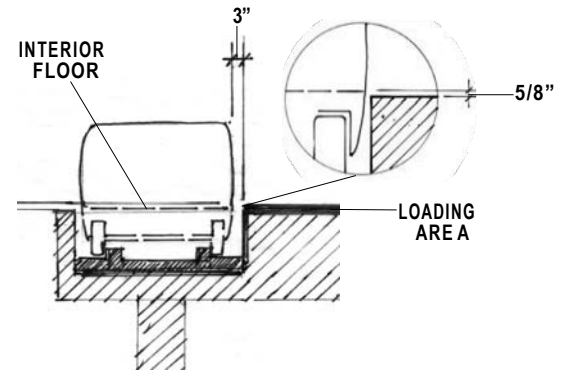

ALLOWABLE GAPS

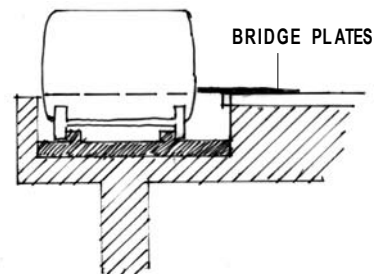

ALTERNATIVE METHOD

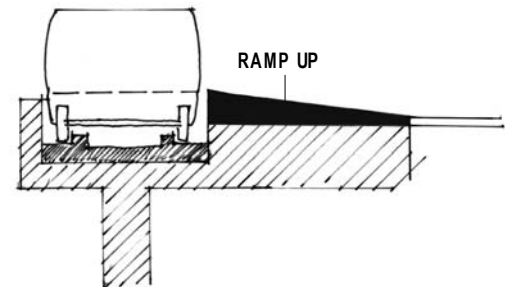

ALTERNATIVE METHOD

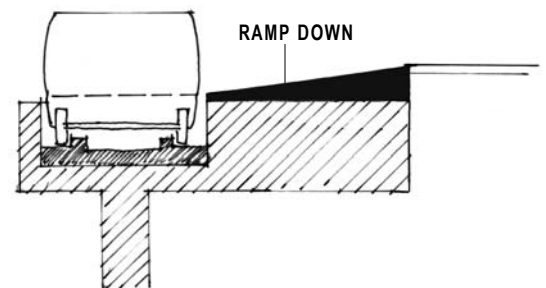

ALTERNATIVE METHOD

- There is no clear headroom requirement for wheelchair spaces on a ride since many rides move through confined spaces. The 80-inch minimum vertical clearance requirement remains for circulation areas and accessible routes in the queue line and load and unload areas.

Openings, Width and Length of Wheelchair Space

Openings and the width and length of wheelchair spaces need to be considered in relation to each other. Openings on rides that provide wheelchair spaces must be at least 32 inches wide. This minimum width is necessary for passage of a wheelchair or mobility device.

Wheelchair spaces must have a clear width of 30 inches minimum and a clear length of 48 inches minimum, measured to at least 9 inches above the floor surface. Wheelchair access can be provided onto the ride vehicle in many ways, including, but not limited to, rear entry, side entry, or side entry with a turntable.

Side Entry Openings, and Width and Length of Wheelchair Space

If the wheelchair space can only be entered from the side, the ride must be designed to permit sufficient turning space for people using a wheelchair or mobility device to enter and exit the ride. Designers must consider the position of the opening in relation to the wheelchair space and add clear space and larger openings as necessary. For example, an opening of 32 inches, combined with a 30-by-48-inch minimum wheelchair space, is not enough space for turning to face the front of the ride vehicle. If there is a 42-inch opening, a wheelchair space with a clear length of 60 inches minimum and a clear width of 36 inches minimum would be needed.

Protrusions

There may be some protrusions into wheelchair spaces on rides, but not into circulation areas, accessible routes, or load and unload areas. Where a wheelchair space is located on a ride, nothing may protrude into the front of the wheelchair space 9 inches from the

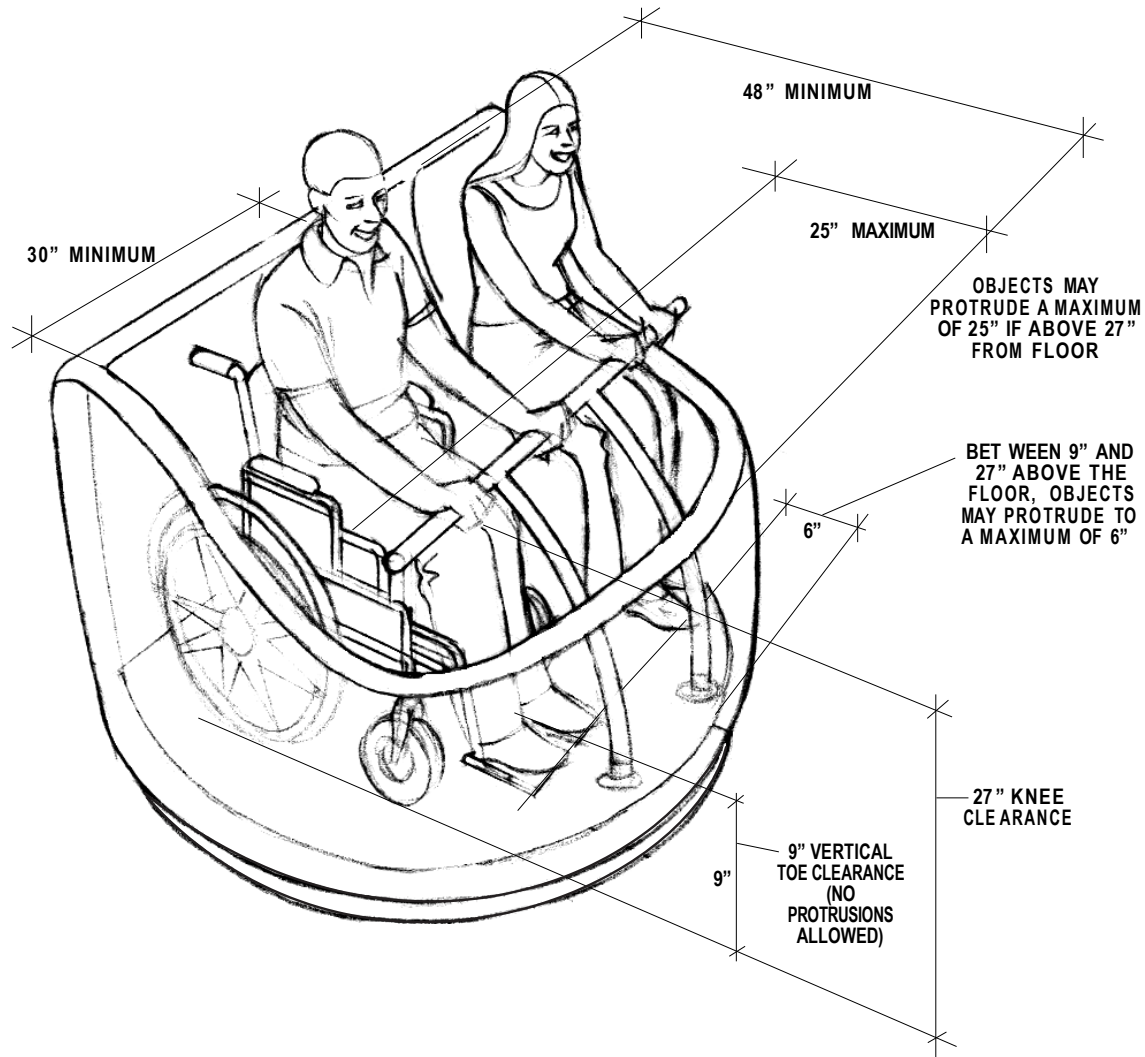

ALLOWABLE PROTRUSIONS INTO WHEELCHAIR SPACES

floor. Objects may protrude into the space a maximum of 6 inches along the front of the space, if they are between 9 inches and 27 inches maximum above the floor. Objects may protrude a maximum of 25 inches along the front of the space if they are more than 27 inches above the floor surface.

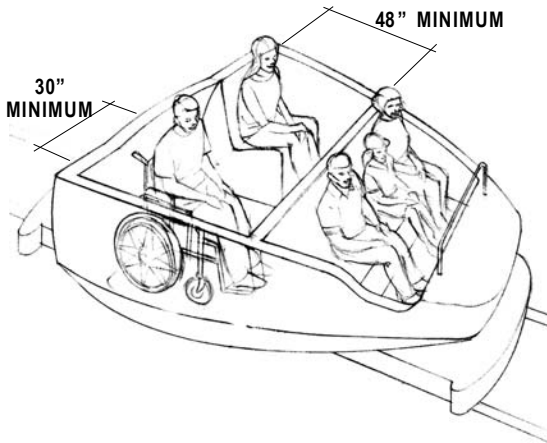

WHEELCHAIR SPACE WITH COMPANION SEATING

Companion Seats

Where companion seating is provided on a ride, companion seating adjacent to wheelchair spaces is also required in some cases. A companion seat is required if the interior of an amusement ride is more than 53 inches wide, there is seating for more than one rider, and the wheelchair doesn't need to be centered within the ride to maintain the center of gravity.

If the ride has shoulder-to-shoulder seating, the companion seating must be shoulder-to-shoulder with the adjacent wheelchair space. If shoulder-to-shoulder companion seating is not operationally or structurally feasible (i.e., in water rides where the rider's center of gravity is critical) operators must comply with this provision to the maximum extent feasible.

Amusement Ride Seats Designed for Transfer

Where an amusement ride seat is designed for transfer, it is expected that someone will transfer only once from a wheelchair or mobility device to the ride seat. Amusement ride seats designed for transfer should allow individuals to make independent transfers to and from their wheelchairs or mobility devices. There are many different ways that individuals transfer from their wheelchairs or mobility devices. Both the clear space and the height of the seat are critical for a safe and independent transfer. When greater distances are required for transfer, consideration should be given to providing gripping surfaces, seat padding, and avoiding sharp or protruding objects.

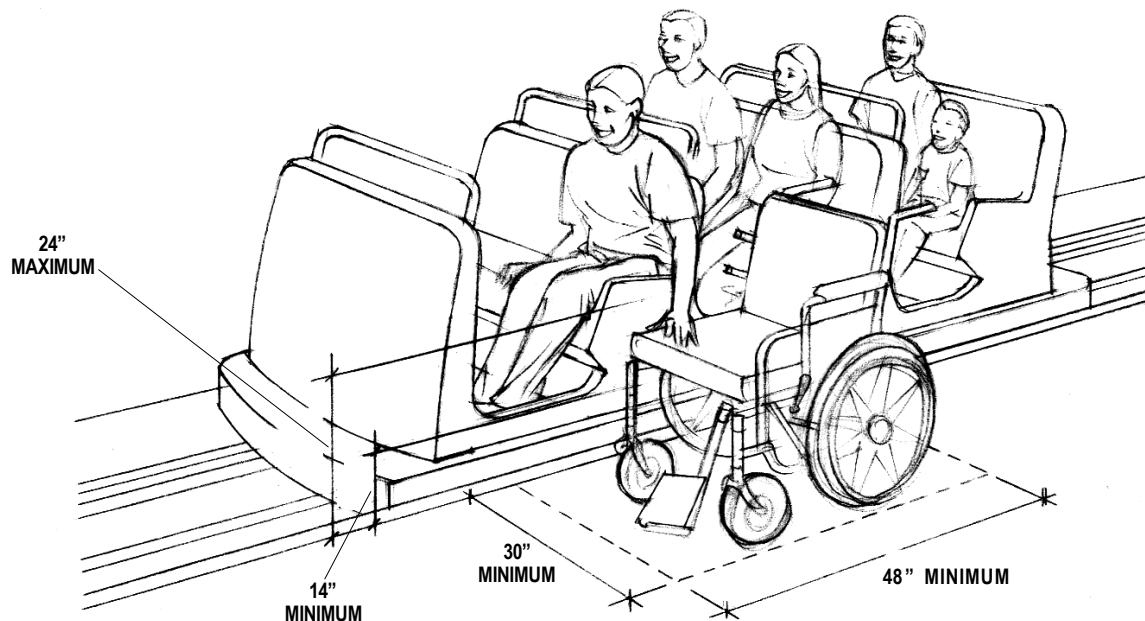

RIDE SEAT DESIGNED FOR TRANSFER

Clear Floor Space

The load and unload areas adjacent to ride seats designed for transfer must have a clear space of 30 by 48 inches minimum. Designers may decide which location is best suited for transfer on a particular ride. Because people transfer in different ways, providing additional space both in front of and to the side of the ride will increase flexibility and usability for a more diverse population.

Transfer Height

Ride seats designed for transfer must be between 14 and 24 inches above the load and unload area surface. Where possible, designers are encouraged to locate the ride seat within 17 to 19 inches above the load and unload surface.

Transfer Entry

There is a large amount of variance in amusement rides and the sides of the ride are often part of the restraint or securement system. For those reasons, the opening provided to

transfer from a wheelchair or mobility device must provide sufficient clearance for transfer.

Transfer Devices for Use with an Amusement Ride

Transfer devices may also be used to provide access onto an amusement ride. A transfer device can be either permanent or temporary and does not require modification to the ride. There are a variety of transfer devices available that could be adapted to provide access onto an amusement ride. Examples of devices that may provide for transfers include, but are not limited to, transfer systems, lifts, mechanized seats, and other custom designed systems.

Operators and designers have flexibility in developing systems that will facilitate individuals to transfer onto amusement rides. These systems or devices should be designed to be reliable and sturdy. A transfer board, provided by the operator, for example, may not be sufficient because it will not provide enough support or stability. However, people using mobility aids may prefer to use their own transfer boards in addition to devices provided by the operator.

Designs that limit the number of transfers required from one's wheelchair or mobility device to the ride seat are encouraged. When using a transfer device to access an amusement ride, the least amount of transfers for the least amount of distance is desired.

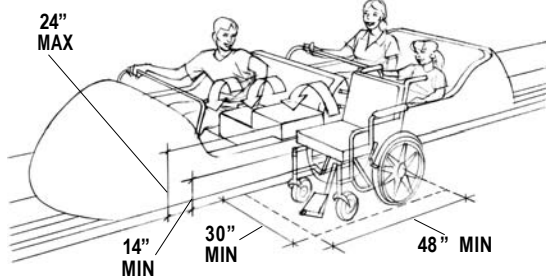

TRANSFER DEVICE: PORTABLE TIER

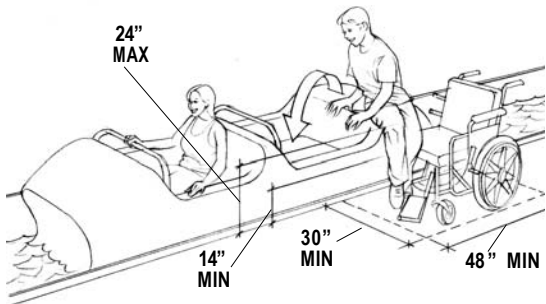

TRANSFER DEVICE: FIXED TIER

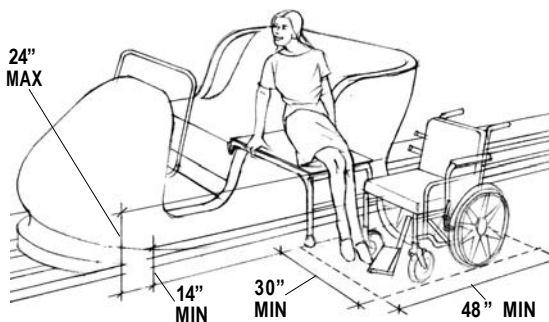

TRANSFER DEVICE: PORTABLE BENCH

Clear Floor Space

The load and unload areas adjacent to transfer devices must have a clear space of 30 by 48 inches minimum. Designers may decide which location is best suited for transfer on a particular ride. Because people transfer in different ways, providing additional space both in front of and to side of the ride will increase flexibility and usability for a more diverse population.

Transfer Height

The height of the transfer device must be between 14 and 24 inches above the load and unload area surface. Where possible, designers are encouraged to locate the transfer device seat within 17 to 19 inches above the load and unload surface. If greater distances are required for transfers, extra consideration should be given to providing gripping surfaces, seat paddings, and avoiding sharp or protruding objects in the path of transfer to better facilitate the transfer process. If multiple transfers are necessary to reach the amusement ride seat, it is recommended that each vertical transfer not exceed 8 inches.

Wheelchair Storage Space

People using wheelchairs and mobility devices need to leave their equipment when they transfer onto rides. There must be space in or adjacent to load and unload areas for each ride seat designed for transfer or transfer device. The space must be a minimum of 30 inches by 48 inches. For safety reasons, this space may not overlap any required means of egress or an accessible route. Most designs for load and unload areas will already include enough space. Operators are not required to provide a constructed element or lockers for storage, only a clear space.

More Information

You can obtain copies of the recreation facility guidelines, which include amusement rides, and further technical assistance from the U.S. Access Board at www.access-board.gov, 1-800-872-2253, or 1-800-993-2822 (TTY).



United States Access Board

1331 F Street, NW, Suite 1000
Washington, DC 20004-1111

voice (800) 872-2253

tty (800) 993-2822

www.access-board.gov



amusement rides boating facilities fishing piers & platforms golf courses miniature golf sports facilities swimming pools & spa

accessible fishing piers & platforms



a summary of
accessibility guidelines
for recreation facilities

JUNE 2003

FDA, Inc.

Table of Contents

Accessibility Guidelines for Recreation Facilities . . .	146
Introduction	146
Fishing Piers and Platforms.....	149
Accessible Routes	150
Gangways	150
Railings	153
Clear Floor or Ground Space	156
Turning Space.....	156
More Information	157

This information has been developed and reviewed in accordance with the Access Board's information quality guidelines (www.access-board.gov/infoquality.htm).

Accessibility Guidelines for Recreation Facilities



USDA FOREST SERVICE

Introduction

The Americans with Disabilities Act (ADA) is a comprehensive civil rights law that prohibits discrimination on the basis of disability. The ADA requires that newly constructed and altered state and local government facilities, places of public accommodation, and commercial facilities be readily accessible to, and usable by, individuals with disabilities. The ADA Accessibility Guidelines (ADAAG) is the standard applied to buildings and facilities. Recreational facilities, including fishing piers and platforms, are among the facilities required to comply with the ADA.

The Access Board issued accessibility guidelines for newly constructed and altered recreation facilities in 2002. The recreation facility guidelines are a supplement to ADAAG. As a supplement, they must be used in conjunction with ADAAG. References to ADAAG are mentioned throughout this summary. Copies of ADAAG and the recreation facility accessibility guidelines can be obtained through the Board's website at www.access-board.gov or by calling 1-800-872-2253 or 1-800-993-2822 (TTY). Once these guidelines are adopted by the Department of Justice (DOJ), all newly designed, constructed and altered recreation facilities covered by the ADA will be required to comply.

The recreation facility guidelines cover the following facilities and elements:

- Amusement rides
- Boating facilities
- Fishing piers and platforms
- Miniature golf courses
- Golf courses
- Exercise equipment
- Bowling lanes
- Shooting facilities
- Swimming pools, wading pools, and spas

This guide is intended to help designers and operators in using the accessibility guidelines for fishing piers and platforms. These guidelines establish minimum accessibility requirements for newly designed or newly constructed and altered fishing piers and platforms. This guide is not a collection of fishing pier designs. Rather, it provides specifications for elements on a fishing pier or platform to create a general level of usability for individuals with disabilities. Emphasis is placed on ensuring that individuals with disabilities are generally able to access the fishing pier and use a variety of elements. Designers and operators are encouraged to exceed the guidelines where possible to provide increased accessibility and opportunities. Incorporating accessibility into the design of a fishing pier should begin early in the planning process with careful consideration to accessible routes and maneuvering space.

The recreation facility guidelines were developed with significant public participation. In 1993, the Access Board established an advisory committee of 27 members to recommend accessibility guidelines for recreation facilities. The Recreation Access Advisory Committee represented the following groups and associations:

- American Ski Federation
- American Society for Testing and Materials (Public Playground Safety Committee)
- American Society of Landscape Architects
- Beneficial Designs
- City and County of San Francisco, California, Department of Public Works
- Disabled American Veterans
- Environmental Access
- Golf Course Superintendents Association of America
- Hawaii Disability and Communication Access Board
- International Association of Amusement Parks and Attractions
- Katherine McGuinness and Associates
- Lehman, Smith, and Wiseman Associates
- Michigan Department of Natural Resources
- National Council on Independent Living
- National Park Service
- National Recreation and Park Association
- New Jersey Department of Community Affairs
- Outdoor Amusement Business Association
- Paralyzed Veterans of America
- Professional Golfer's Association
- Self Help for Hard of Hearing People
- States Organization for Boating Access
- Universal Studios
- U.S. Army Corps of Engineers
- U.S. Forest Service
- Y.M.C.A. of the U.S.A.
- Walt Disney Imagineering



The public was given an opportunity to comment on the recommended accessibility guidelines, and the Access Board made changes to the recommended guidelines based on the public comments. A notice of proposed rulemaking (NPRM) was published in the Federal Register in July 1999, followed by a five-month public comment period. Further input from the public was sought in July 2000 when the Access Board published a draft final rule soliciting comment. A final rule was published in September 2002.

“Whenever a door is closed to anyone because of a disability, we must work to open it.... Whenever any barrier stands between you and the full rights and dignity of citizenship, we must work to remove it, in the name of simple decency and justice. The promise of the ADA...has enabled people with disabilities to enjoy much greater access to a wide range of affordable travel, recreational opportunities and life-enriching services.”

President George W. Bush, New Freedom Initiative, February 1, 2001

Fishing Piers and Platforms

The recreation facility guidelines described in this guide focus on newly designed or newly constructed and altered fishing piers and platforms. Other provisions contained in ADAAG address elements commonly found at a fishing facility, such as accessible vehicle parking



SPACE COAST SPORTFISHING FOUNDATION

spaces, exterior accessible routes, and toilet and bathing facilities. ADAAG addresses only the built environment (structures and grounds). The guidelines do not address operational issues. Questions regarding operational issues should be directed to the Department of Justice, 1-800-514-0301 or 1-800-514-0383 (TTY).

These guidelines only apply to facilities specifically designed and constructed for fishing. Structures that were not built specifically for fishing do not need to meet these requirements, even if people use them for fishing (for example, a bridge, flood control dam or breakwater jetty).

Accessible Routes

ADAAG requires that at least one accessible route connect accessible buildings, facilities, elements and spaces on the site. Accessible fishing piers and platforms and other accessible spaces and elements within a fishing facility must also be connected by an accessible route. The accessible route must comply with ADAAG provisions for the location, width (minimum of 36 inches), passing space, head room, surface, slope (maximum of 1:12 or 8.33%), changes in level, doors, egress, and areas of rescue assistance, unless otherwise modified by specific provisions outlined in this guide.



Gangways

A gangway is a variable-sloped pedestrian walkway linking a fixed structure or land with a floating structure. Where gangways are provided as part of accessible routes to connect floating accessible fishing piers or platforms, the following exceptions to ADAAG have been included to deal with the varying water level changes and other factors in this dynamic environment. Designers and operators should note that there are no exceptions to the accessible route requirements where the accessible route connects to a fixed fishing pier or platform.

Gangway Slope and Rise Exceptions

Gangways must be designed to provide for a maximum 1:12 (8.33%) slope but are not required to be longer than 30 feet in length. There is no maximum slope requirement for gangways 30 feet or longer. For example, where the vertical distance between where the gangway departs the landside connection and the elevation of the pier surface at the lowest water level is 4 feet, the gangway would have to be at least 30 feet long. As water levels rise and fall, gangway slopes also rise and fall. At times, this gangway slope may be less than 1:20 (5%) and at other times it may be more than 1:12 (8.33%). Designers are encouraged to provide the least possible gangway slope, where possible, to give independent access to persons with disabilities.

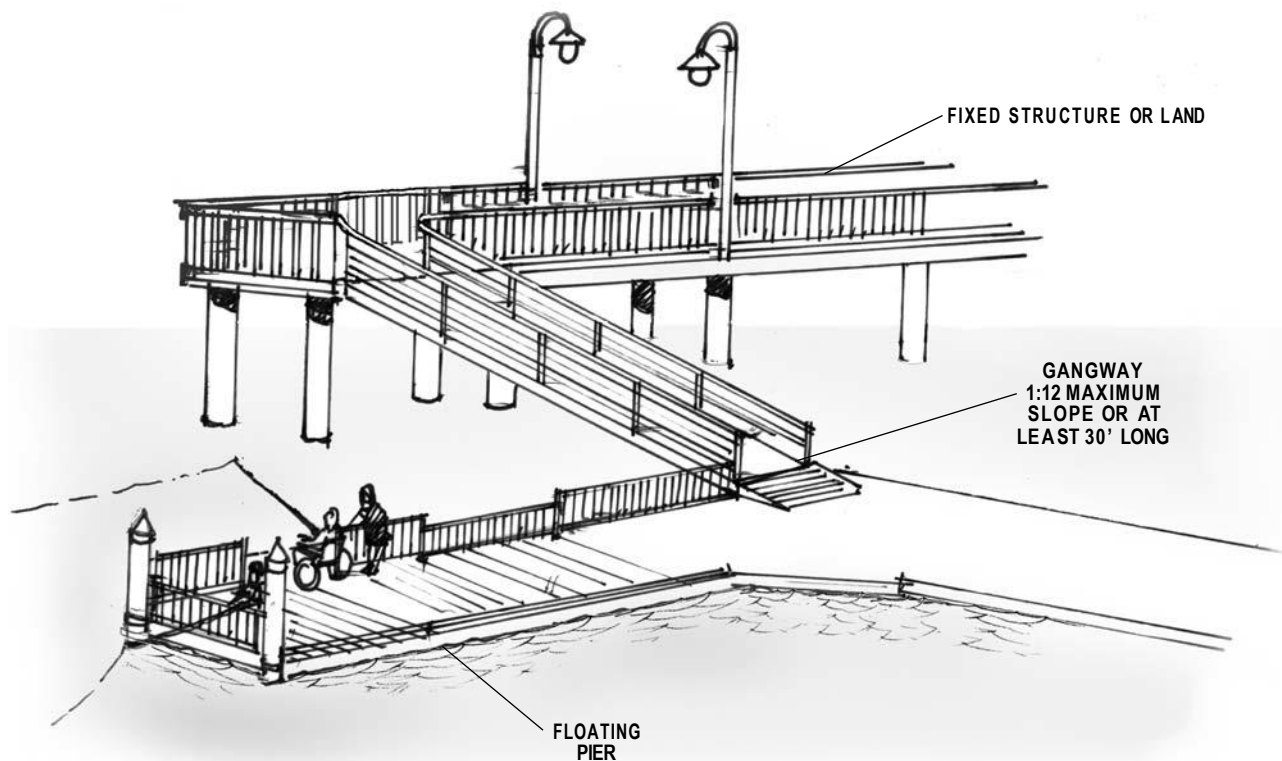

ACCESSIBLE GANGWAY SERVING ACCESSIBLE FLOATING PIER IN A LARGE FACILITY

The maximum rise requirements in ADAAG do not apply to gangways. As a result, no intermediate landings on the gangways are required and gangways may be any length.

The gangway slope and rise exceptions do not apply to other sloped walking surfaces that may be part of the accessible route. For example, where a non-gangway sloped walking surface greater than 1:20 (5%) is provided as part of an accessible route connecting accessible elements at a fishing facility, it must comply with ADAAG slope and rise requirements. This would include a ramp connecting a fixed pier or a float with fixed switchback ramps.

Gangway Alterations

Gangways on existing fishing facilities may be repaired or replaced without triggering the requirement to increase the gangway length. However, if the areas altered contain primary functions (such as a fishing station), existing gangways are considered part of the path of travel to the altered primary function areas and must be made accessible, if the cost to do so is not disproportionate. The Department of Justice has determined that it is not disproportionate to spend up to an additional 20 percent of the overall costs of alterations to the primary function area to make the path of travel accessible.

Transition Plates

Transition plates are sloping pedestrian walking surfaces located at the end of a gangway. Gangways are not required to have landings at the end, if transition plates are provided. If the slope of the transition plate is greater than 1:20 (5%), transition plates must have a landing at the end of the transition plate not connected to the gangway and comply with other ADAAG ramp requirements.

Handrail Extensions

ADAAG addresses handrail height, diameter, and extensions provided to the end of the gangway. Other specifications regarding vertical supports may be addressed in other building codes. Handrail extensions are not required where gangways and transition plates connect and both are provided with handrails. ADAAG does not require handrails



BUREAU OF LAND MANAGEMENT

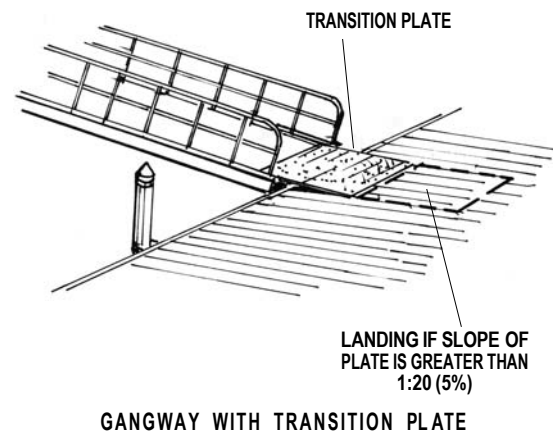

2000 International Building Code

1003.2.12.1 Height. Guards shall form a protective barrier not less than 42 inches (1067 mm) high, measured vertically above the leading edge of the tread, adjacent walking surface or adjacent seatboard.

Exception: For occupancies in Group R-3, and within individual dwelling units in occupancies in Group R-2, both as applicable in Section 101.2, guards whose top rail also serves as a handrail shall have a height not less than 34 inches (864mm) and not more than 38 inches (965mm) measured vertically from the leading edge of the stair tread nosing.

1003.2.12.2 Opening limitations. Open guards shall have balusters or ornamental patterns such that a 4-inch-diameter (102mm) sphere cannot pass through any opening up to a height of 34 inches (864mm). From a height of 34 inches (864mm) to 42 inches (1067mm) above the adjacent walking surfaces, a sphere 8 inches (203mm) in diameter shall not pass.

Exception: The triangular opening formed by the riser, tread and bottom rail at the open side of a stairway shall be of a maximum size such that a sphere of 6 inches (152mm) in diameter cannot pass through the opening.

[Exceptions 2 through 4 not reprinted.]

Source: Sections 1003.2.12.1 and 1003.2.12.2, International Building Code. Reprinted with permission of the International Code Council, Falls Church, Virginia.

on sloped surfaces that have a rise of less than 6 inches or a projection less than 72 inches, or a slope of 1:20 (5%) or less. If handrail extensions are provided, they do not need to be parallel with the ground or floor surface, since the surface may be moving due to water conditions.

Cross Slope

The cross slopes of gangways, transition plates and floating piers that are part of an accessible route must be designed and constructed not to exceed a maximum of 2 percent. Measurements, absent live loads, are to be made from a static condition (i.e., absence of movement that results from wind, waves, etc.). Where floating piers are grounded out due to low water conditions, slope requirements would not apply.

Elevators and Platform Lifts

In addition to regular elevators, limited use/limited application elevators or platform lifts that comply with ADAAG may be used instead of gangways as part of an accessible route connecting floating piers and platforms used for fishing.

Railings

Where railings, guards, or handrails are provided on a fishing pier or platform, they must meet ADAAG provisions.

Height

Where railings, guards, or handrails are provided on a fishing pier or platform, at least 25 percent of the rails must

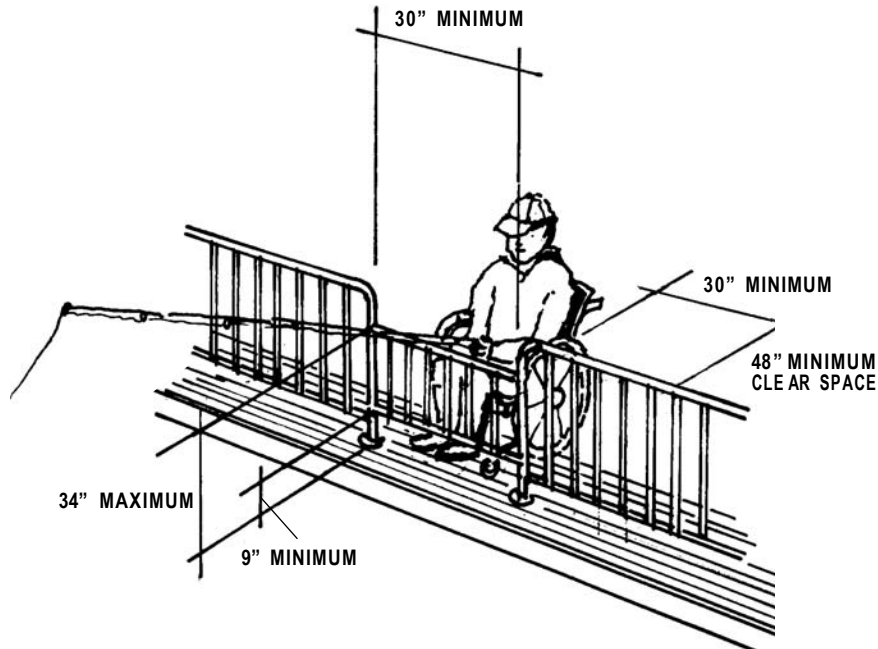

RAILING HEIGHTS AND CLEAR SPACE

be 34 inches or less in height above the ground or deck so a person using a wheelchair or other mobility device has the opportunity to fish. However, guardrails may be higher than 34 inches if the higher portion meets all the requirements of the International Building Code. (See sidebar.)

This will allow a design professional to increase the guardrail height if a specific location needs enhanced safety measures or a local building code applies.

Dispersion

Anglers who can stand are able to fish from any part of a pier or platform and change locations. To provide anglers with disabilities similar opportunities, the accessible 34-inch

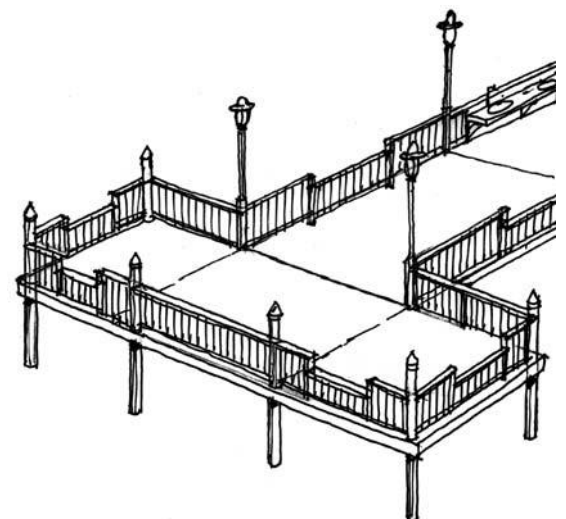

DISPERSION

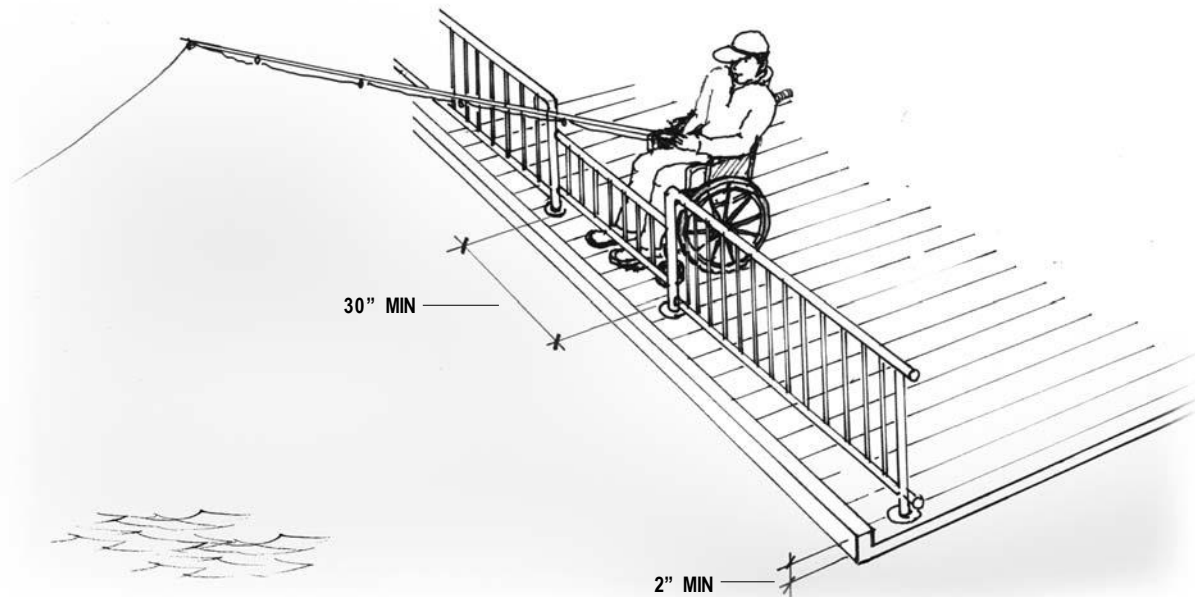

2-INCH EDGE PROTECTION AT PIER

maximum railing must be located in a variety of places on the pier or platform to offer a variety of locations to fish from. Different fishing locations may provide different water depths, shade or sun, vegetation, and proximity to the shoreline or bank.

Edge Protection

Where railings, guards, or handrails are provided, edge protection must be provided and extend a minimum of 2 inches above the ground or deck surface. This protection will prevent persons using wheelchairs or other mobility devices from slipping off the pier or platform.

Edge protection is not required where a railing, guardrail, or handrail is provided, if the deck surface extends a minimum of 12 inches beyond the inside face of the railing. This design allows a person using a wheelchair or other mobility device to pull into a clear space and move beyond the face of the railing to view the water in different directions. Toe clearance

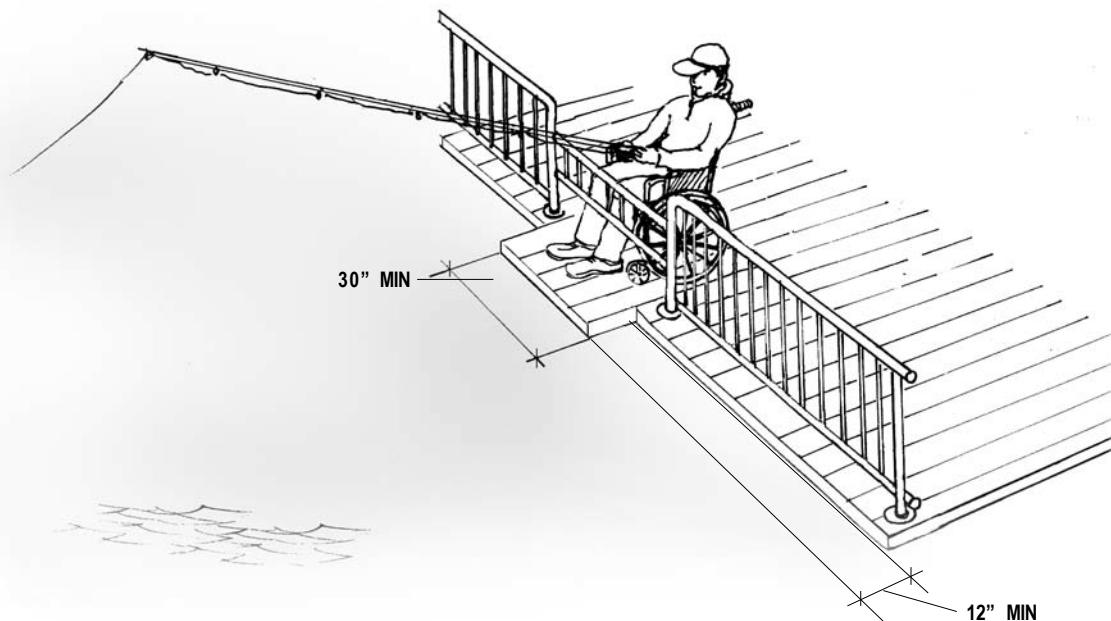

12-INCH DECK EXTENSION WITHOUT EDGE PROTECTION

must be at least 30 inches wide and a minimum of 9 inches above the ground or deck surface beyond the railing.

Clear Floor or Ground Space

At least one clear floor or ground space (30 inches by 48 inches minimum) must be provided at each location that has a railing height of 34 inches maximum. If there are no railings, at least one clear space must be provided on a pier or platform. (See top illustration on page 9.)

Turning Space

Piers and platforms must have at least one turning area, either a 60-inch turning space or T-shaped space, to allow a person using a mobility device or wheelchair to make a 180-degree turn. The space may overlap the accessible route and clear floor or ground space.

More Information

You can obtain copies of the recreation facility guidelines, which include fishing piers and platforms, and further technical assistance from the U.S. Access Board at www.access-board.gov, 1-800-872-2253, or 1-800-993-2822 (TTY).



United States Access Board

1331 F Street, NW, Suite 1000
Washington, DC 20004-1111

voice (800) 872-2253

tty (800) 993-2822

www.access-board.gov