

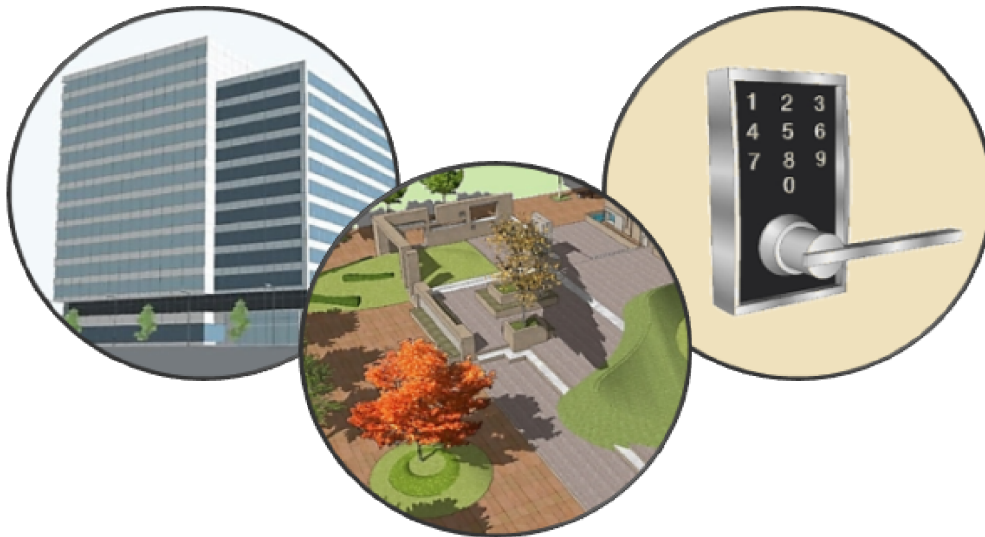

# ADA- Operable Parts, Drinking Fountains & Stairways



**3**

**Professional Development Hours (PDH) or  
Continuing Education Hours (CE)  
Online PDH or CE course**

# Operable Parts

This guide explains requirements in the ADA Standards for operable parts.

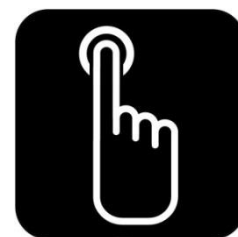

## Operable Parts Covered [§205]

Compliance is required for operable parts located in accessible spaces and along accessible routes. Operable parts include light switches, electrical and communication receptacles, thermostats, alarm pulls, automatic door controls, and other elements used by facility occupants.

### Examples of Operable Parts

*Compliance is required for the operable portions of fixed elements, such as cabinet hardware, but not for inoperable portions or to non-fixed components, such as fire extinguishers.*

*Electrical outlets, alarm pulls, and many other types of receptacles and controls are covered.*

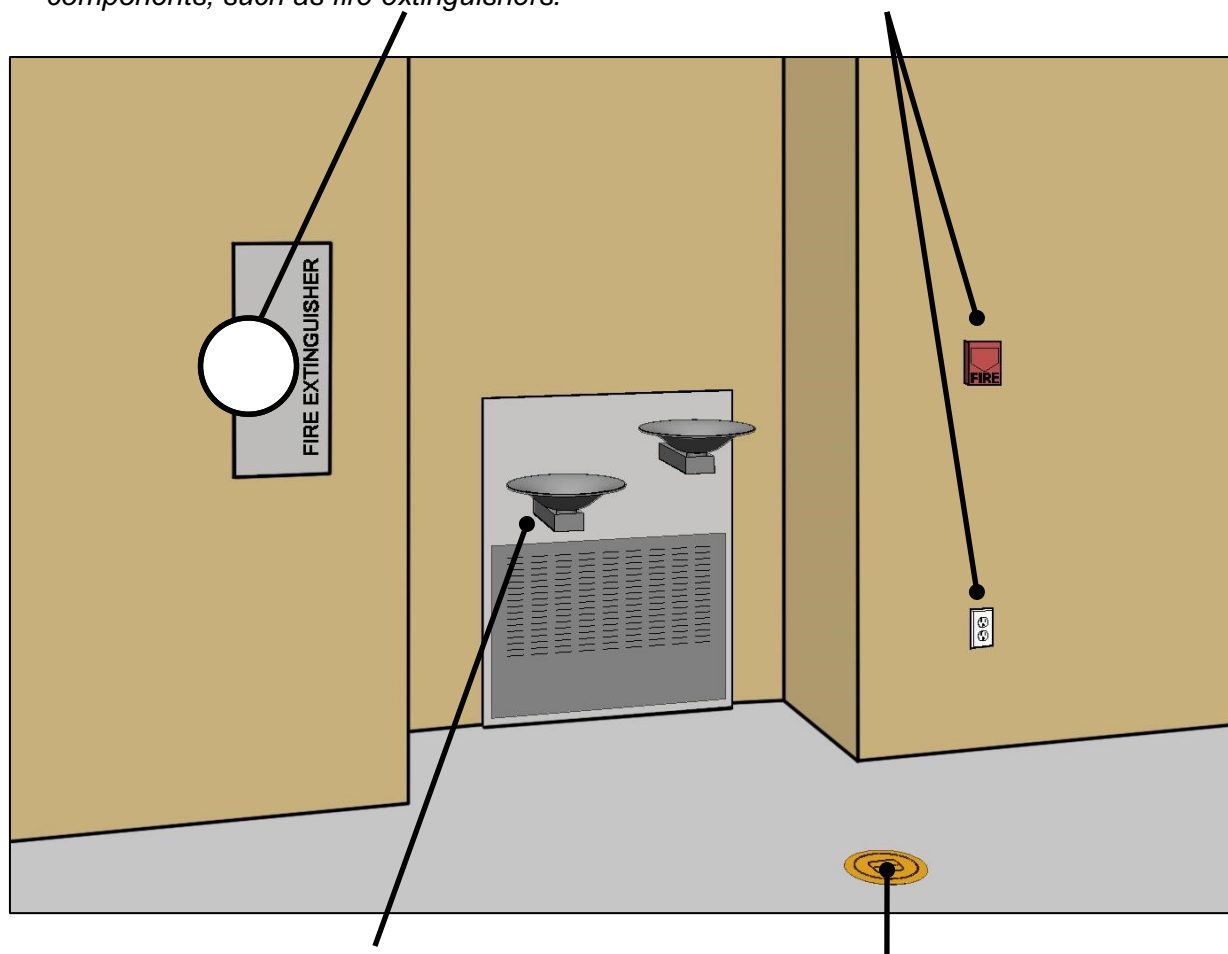

*Provisions for drinking fountains and other elements covered by the standards also apply the criteria for operable parts.*

*Exempt: floor receptacles and operable parts used only by service or maintenance personnel.*

## Examples of Operable Parts in Kitchens

*Electrical outlets, switches, and faucet controls are required to comply.*

*Exempt: HVAC diffusers and dedicated electrical or communication receptacles.*

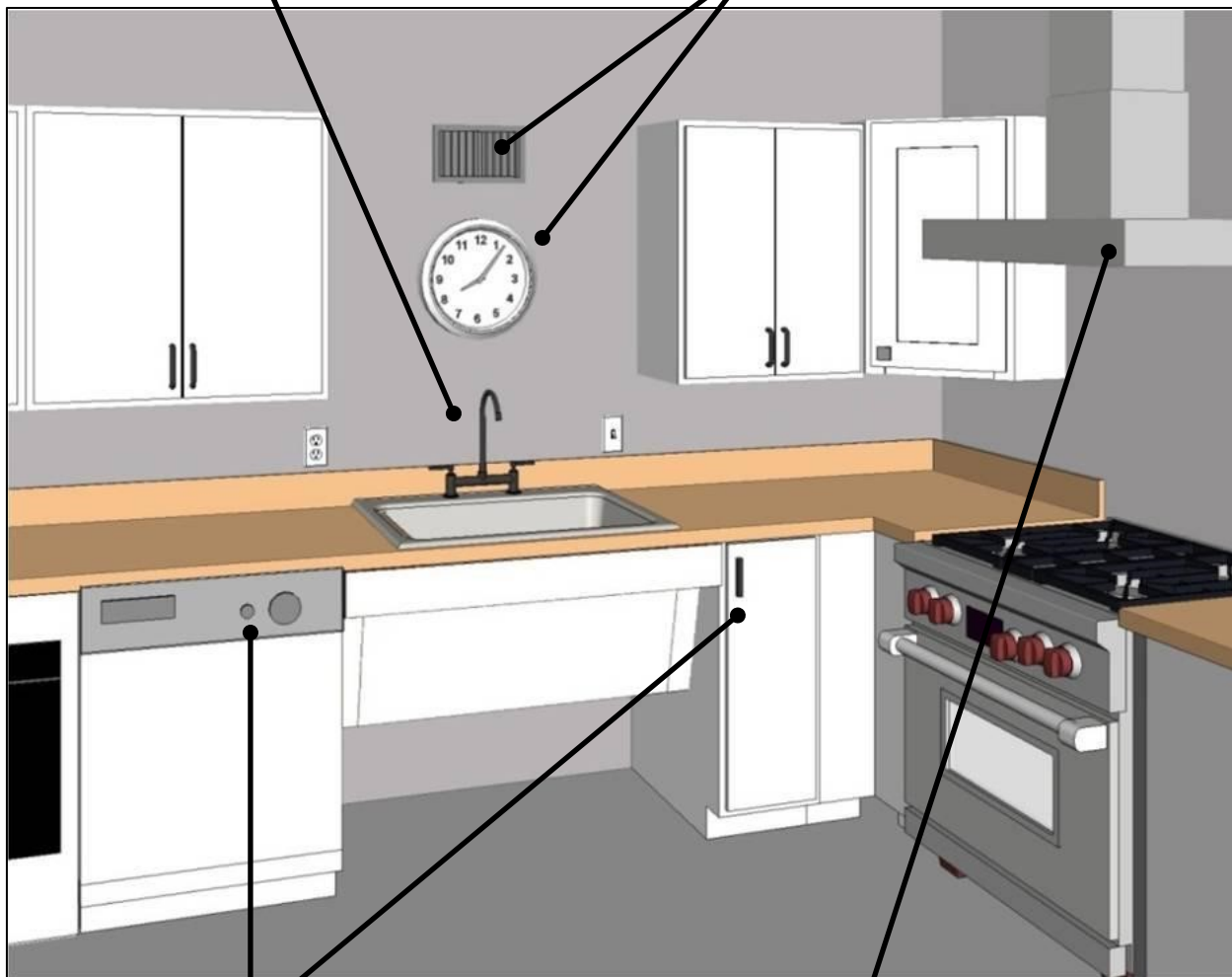

*Appliance controls and handles to accessible storage are also covered operable parts. control.*

*Controls on elements outside reach range, such as range hoods, require provision of a second as*

*If redundant controls (other than light switches) are provided for an element, one control in each space is not required to comply.*

## Operable Parts [§309]

Requirements apply generally to all types of operable parts covered. They are also referenced by technical sections of the standards covering drinking fountains, faucet and flush controls, ATM and fare machines, appliances, storage, windows, and door and gate hardware, and other elements.

### Accessible Features of Operable Parts

*Operable portions meet usability criteria and are within accessible reach ranges (non-operable portions can be located outside reach range)*

*Clear floor space for approach and positioning*

*An unobstructed side of the clear floor space adjoins a connecting accessible route*



### Forward and Side Approaches

At most elements, clear floor space can be positioned for either a forward approach or a side approach. A forward approach is required at some elements, such as drinking fountains and lavatories, for easier access.

## Forward Approach and Reach

### Clear Floor Space [§309.2]

Clear floor space for forward approaches must extend up to or, if knee or toe space is provided, below operable parts. This facilitates access since the forward reach does not extend beyond a wheelchair user's toes.

If clear floor space is obstructed on both sides more than half the minimum required depth, a wider clearance (36" min.) is required for maneuvering and sway.

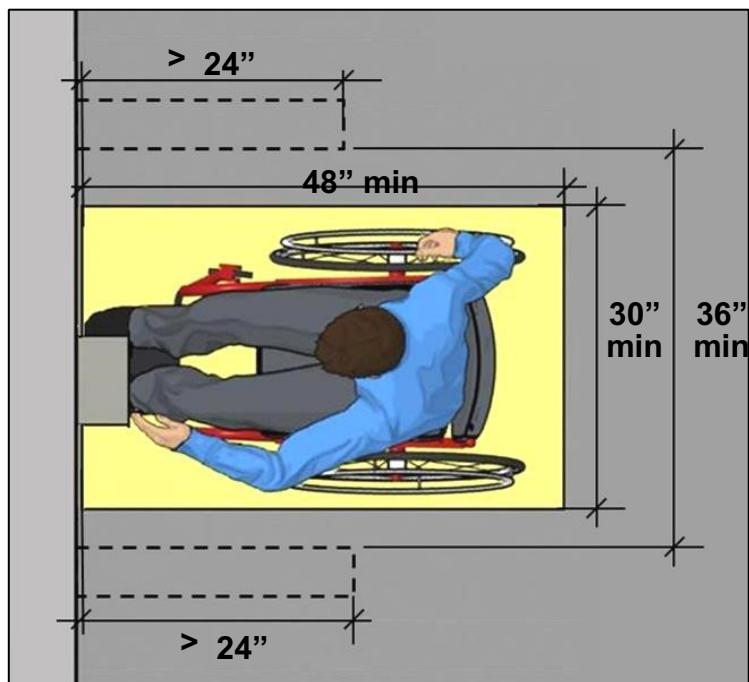



### Forward Reach [§308.2]

The range for unobstructed reaches (15" – 48") applies only to those portions of elements that are operable. Non-operable portions can be located outside the range.

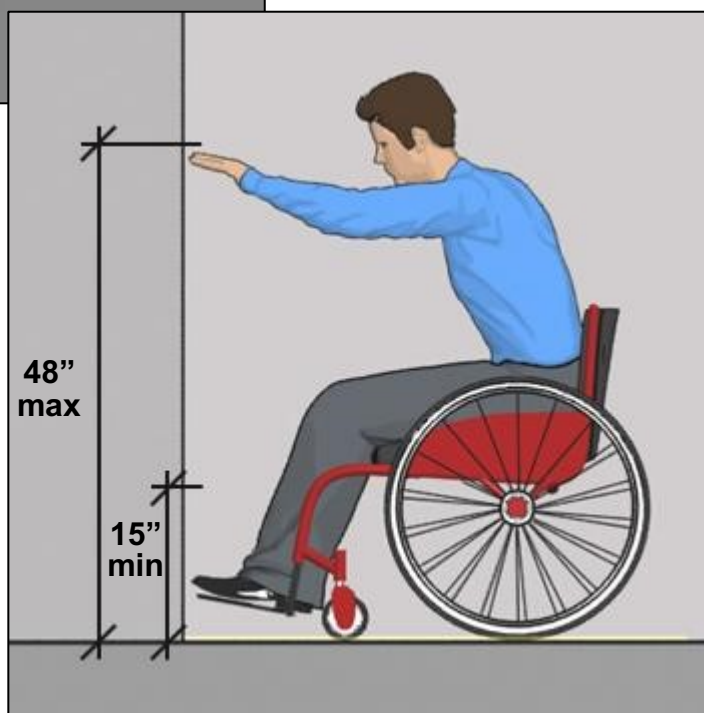

### Knee and Toe Space

If the forward reach to operable parts extends over an obstruction, such as a counter, clearances for toes and knees is required below. The knee and toe space must be at least as deep as the reach depth measured from the leading edge of the obstruction.

## Obstructed High Reach

The maximum reach of 48" is reduced to 44" when the depth of reach over an obstruction exceeds 20." Knee and toe space must extend the full depth of reach.

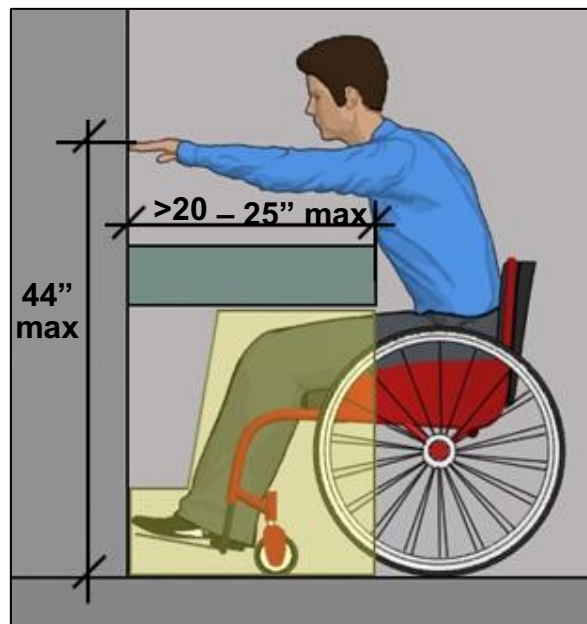
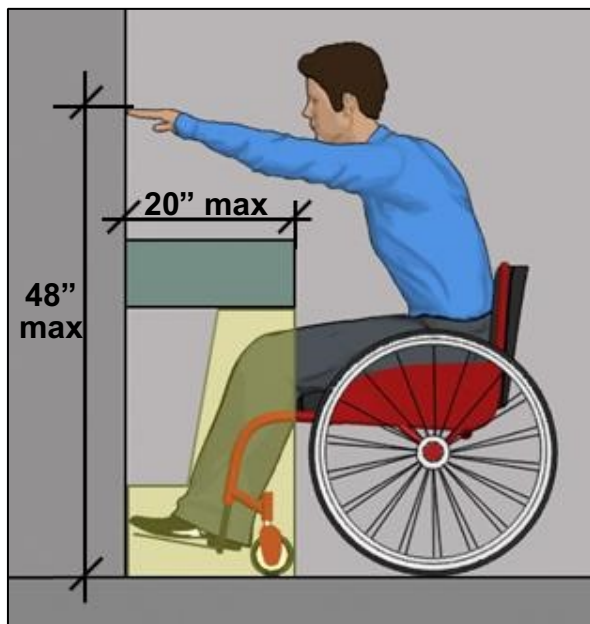

## Side Approach and Reach



## Clear Floor Space [§309.2]

Clear floor space can be oriented for a side approach instead of a forward approach at most operable parts. Nominal centering of the space on operable portions of elements is advisable, but not required (except at washers and dryers).

### Clear Floor Space

Additional clearance is required if the space is obstructed on three sides for more than half the depth to allow easier maneuvering into the space.

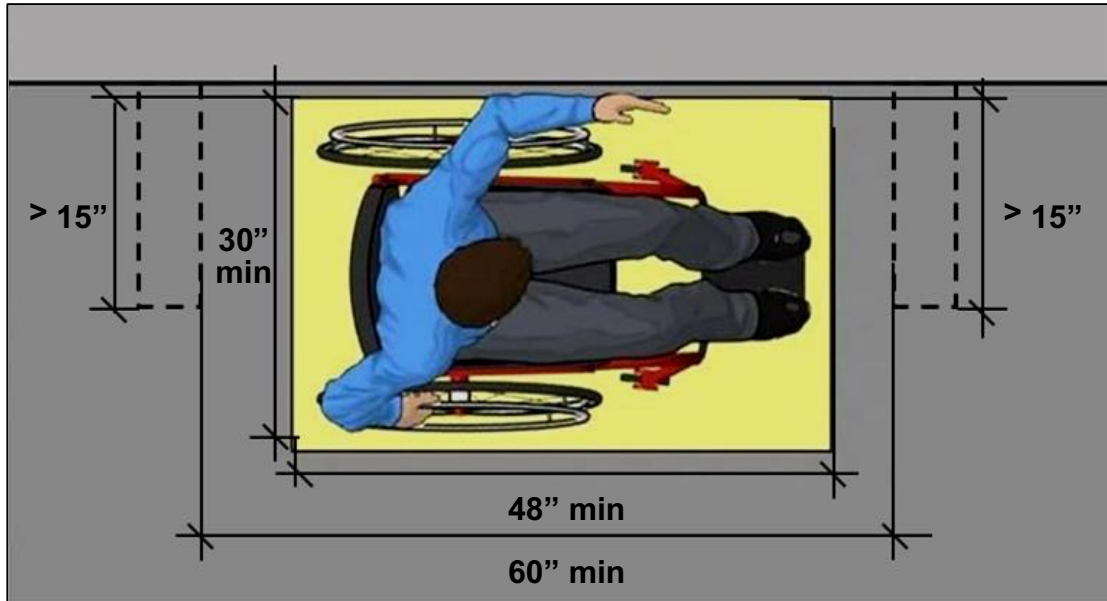

#### **Fuel Dispensers**

*The operable parts of fuel dispensers located on existing curbs can be up to 54" high.*



### Side Reach [§308.3]

The range for side reach, like forward reach is 15" to 48" if unobstructed. The maximum reach depth for this range is 10" measured from the available clear floor space.

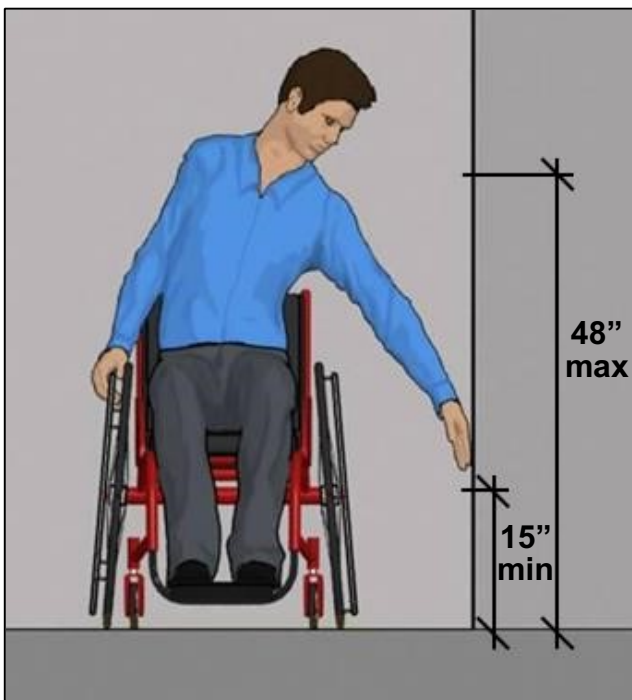

### Obstructed High Reach

The maximum high reach is reduced to 46" when the reach over an obstruction is deeper than 10" (to a maximum of 24"). Obstructions at side reaches are limited to a height of 34".

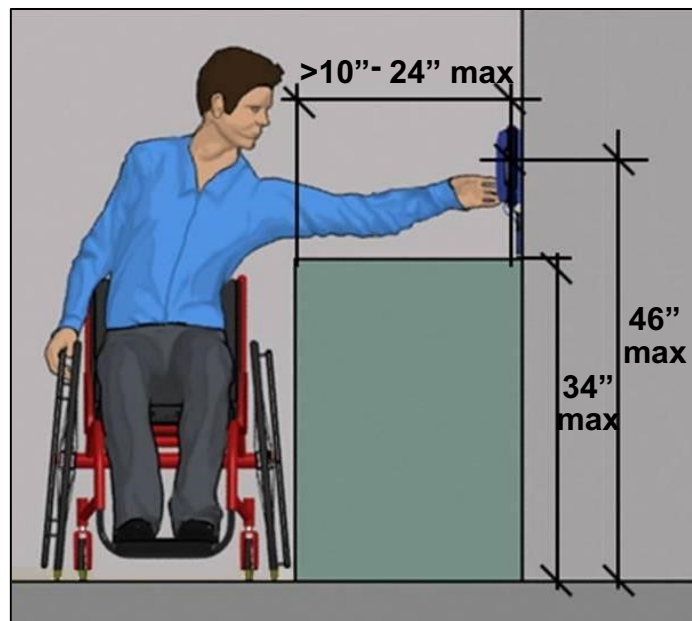
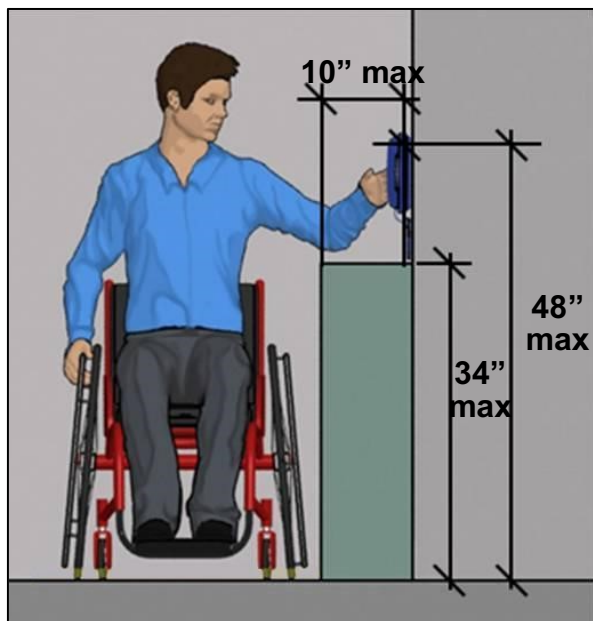

## Side Reach Radius

Elements located in corners can be difficult to reach from a side approach.



*Recommendation:* Where a side reach is provided, locate elements away from corners in consideration of the typical reach radius.

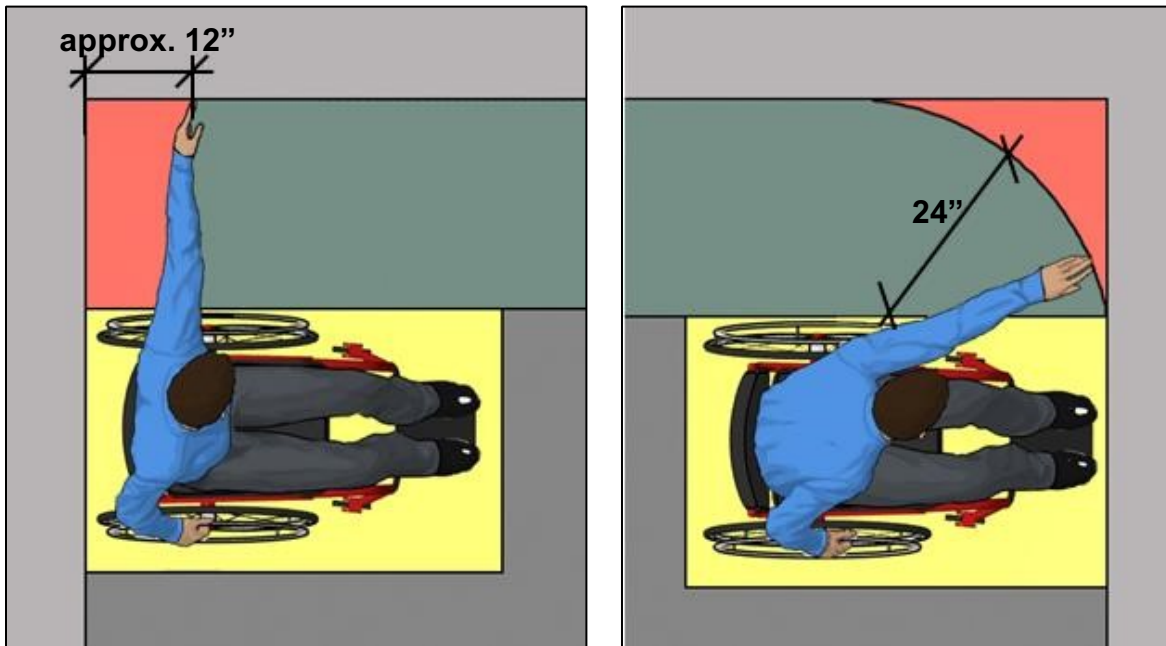

## Advisory Reach Range for Children

The standards include advisory (non-mandatory) reach ranges based on children's dimensions that can be followed when operable parts are designed for use by children. This guidance provides reach ranges recommended according to three age groups.

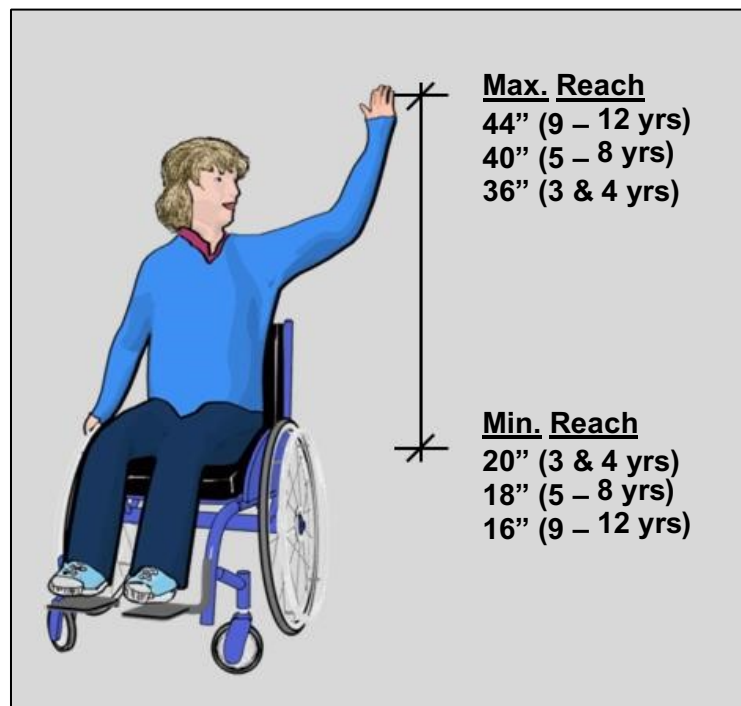

## Operation [§309.4]

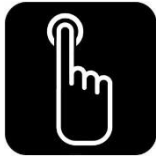

Operable parts must be usable with one hand and not require:

- tight grasping, pinching, or twisting of the wrist, or
- more than 5 pounds of force (lbf) to operate.

Parts that can be operated without hand or finger dexterity, fine motor movement, or simultaneous actions provide easier access and accommodate a broader range of users.

## Push Plates, Buttons, and Bars

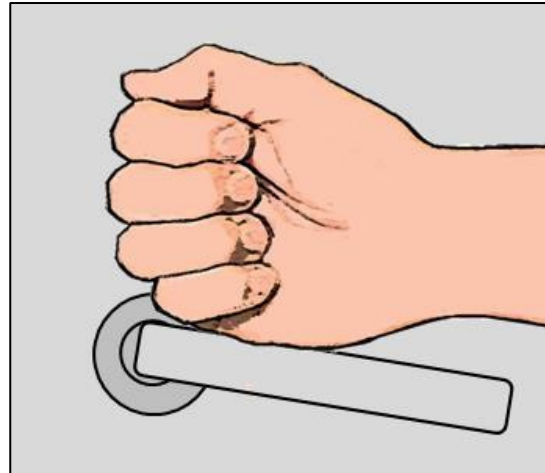

*Operability with a closed fist is a reliable test of usability, but is not required by the standards.*

Push-activated controls not requiring more than 5 lbf are acceptable. Buttons that are raised or flush are easier to use than those that are recessed. (Elevator control buttons cannot be recessed, and input keys at ATM and fare machines must be raised.)

## Handles, Pulls, and Knobs



Standard U-shaped pulls and lever-shaped handles are acceptable. Stationary knobs with a shape that can be loosely gripped also are

acceptable. Knobs that require a full hand grip and turning, including round door knobs and shower controls, do not comply because they require twisting

of the wrist.

## Latches and Locks



Latches and locks with small parts that must be manipulated can be difficult to use and will not comply if pinching is necessary. However, non-fixed portions of locks and other operable parts, such as keys and access cards, are not required to comply (but those that do not require pinching or turning provide better access). Hardware that does not require simultaneous actions are better, but some types, such as handles with thumb latches are acceptable.

## Controls and Switches



Dials and other controls that can be turned with the fingers but not the full hand can be used if they do not require twisting of the wrist or pinching. Flip switches and similar controls are acceptable, though push plate types can provide easier access.

## Common Questions



*Are redundant controls for an element required to comply?*

If redundant controls, other than light switches, serve a single element, one control in each space is not required to comply. If a redundant control is located in a different space, however, it must comply. All light switches are required to comply.

*What types of electrical or communication receptacles are exempt because they serve a “dedicated use”?*

Electrical receptacles serving a dedicated use include those installed for appliances, including refrigerators, ranges, and dishwashers, and wall clocks. Floor electrical receptacles are also exempt. Communication receptacles serving a dedicated use include phone jacks, data ports, network and audio-visual connections. Electrical receptacles provided for portable communication devices such as TTYs are not covered by this exception and must comply.

*Do reach range requirements apply to elements or only to operable parts of elements?*

Reach range requirements apply to the operable portions of elements, including handles, controls, switches, buttons, control pads and other mechanisms that must be activated or manipulated for use. Non-operable portions of elements do not have to be within accessible reach ranges.

*Must operable parts be usable with a closed fist?*

Closed-fist operation is a good performance test but is not required by the standards. Many types of operable parts, such as pull handles, satisfy the requirements even though they may not be operable with a closed fist.

*Are turn-key locks prohibited by the standards?*

Key locks or key cards are not prohibited by the standards which apply only to the fixed portions of operable parts. Similarly, items dispensed by ATMs and fare machines, such as receipts, cash, fare cards, and vending machine products are not covered by the standards.

# Drinking Fountains

This guide explains requirements in the ADA Standards for drinking fountains.



## Required Compliance [§211]

Where drinking fountains are provided, access is required for both people who use wheelchairs and for standing persons. This dual access must be provided on each floor of a facility equipped with drinking fountains, as well as an exterior site and each secured area of a building where drinking fountains are provided. Where one unit is planned in any of these locations, at least two units or a combination high-low unit must be provided for dual access in each such location. If multiple units are planned on a floor, exterior site, or secured area, then 50% must be wheelchair accessible and 50% accessible for standing persons (rounding up for either type in the case of odd numbers).

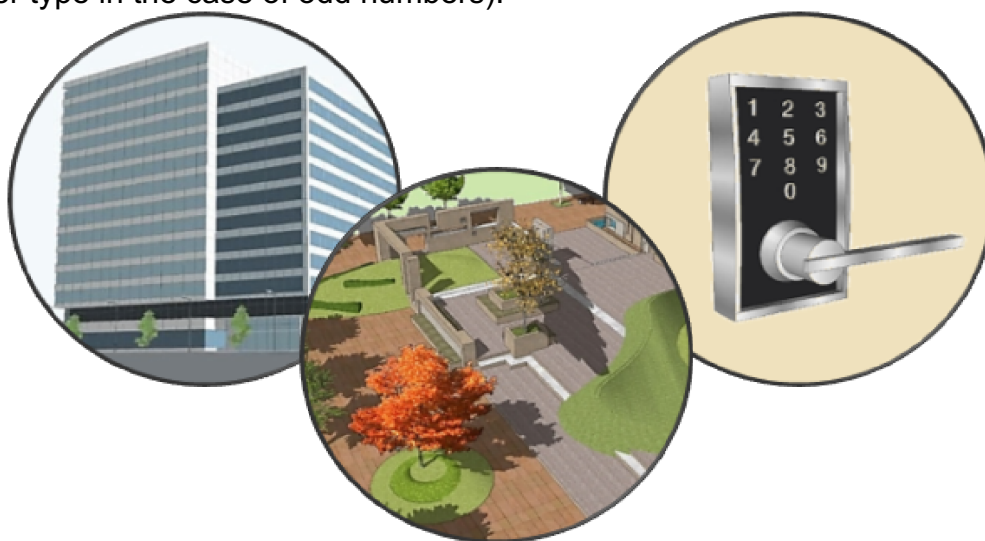

*Scoping for drinking fountains applies separately to each floor of a facility, secured area, and exterior site that contains drinking fountains. In each such location with drinking*

*fountains, half of the units must be wheelchair accessible and the other half accessible for standees. If only one unit is planned in any of these locations, at least two separate units or a combination high-low unit is required for dual access.*



**Recommendation:** Where multiple units are provided on a floor, exterior site, or secured area, provide both wheelchair and standing access at each location for greater convenience, especially if units are separated by significant distances.

## Secured Areas

The Standards specifically address access to drinking fountains located within secured areas because they often serve only a portion of a facility's occupants. The term "secured area" is intended to apply to any space where entry is restricted or controlled. Levels of security can range from rooms entered only with an access card to high-security environments such as holding areas of prisons and jails. (In detention and correctional facilities, units that only serve inaccessible housing or holding cells but not accessible cells are exempt (§211.1, Ex).)



## Alterations and Additions [§202]

In alterations and additions, requirements for drinking fountains apply where units are altered, replaced, or added to a facility (§202.2, §202.3). Access to drinking fountains is also required when alterations or additions are made to areas containing a primary function (i.e., a major activity intended for a facility). Primary function areas that are altered or added to a facility must be connected by an accessible path of travel which includes, where provided, compliant drinking fountains, as well as restrooms and telephones, serving the primary function area. The accessible path of travel is required to the extent that it does not cost more than 20% of the cost of the work to the primary function area (§202.4). See the Alterations and Additions Guide. [See ABA text – p.8]

## Water Coolers and Bottle Fillers

If a drinking fountain is provided, a water cooler, bottle filler, or nearby sink cannot substitute for either the wheelchair accessible or the standing height drinking fountain in new construction, additions, or alterations. Water coolers and bottle fillers can be provided at, or integrated with, compliant drinking fountains. No drinking fountains are required where none are planned, including where water coolers or bottle fillers are provided.

When provided, fixed or built-in water coolers and bottle fillers must meet requirements for operable parts (§309), including:

- location on an accessible route;
- clear floor space for either a forward or side approach; and
- controls, if hand-operated, that are within accessible reach range and are usable with one hand and without tight grasping, pinching, twisting of the wrist, or more than 5 pounds force.

Bottle fillers must comply where provided, including when integrated with drinking fountains. If only one bottle filler is provided at only some drinking fountains or at one bowl of a hi-lo unit, it is advisable to locate it at the wheelchair accessible unit or bowl.

## Wheelchair Accessible Drinking Fountains [§602.1 – §602.6]

Provisions for wheelchair accessible units require access for a forward approach and address spouts, water flow, and operable parts. Units can be wall mounted or free-standing.

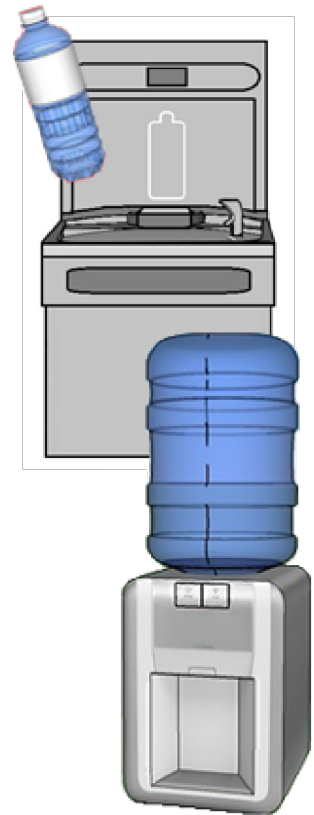

## Wheelchair Accessible Drinking Fountains

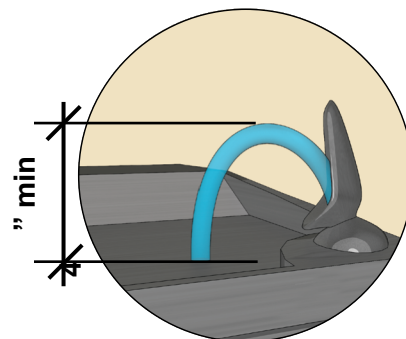
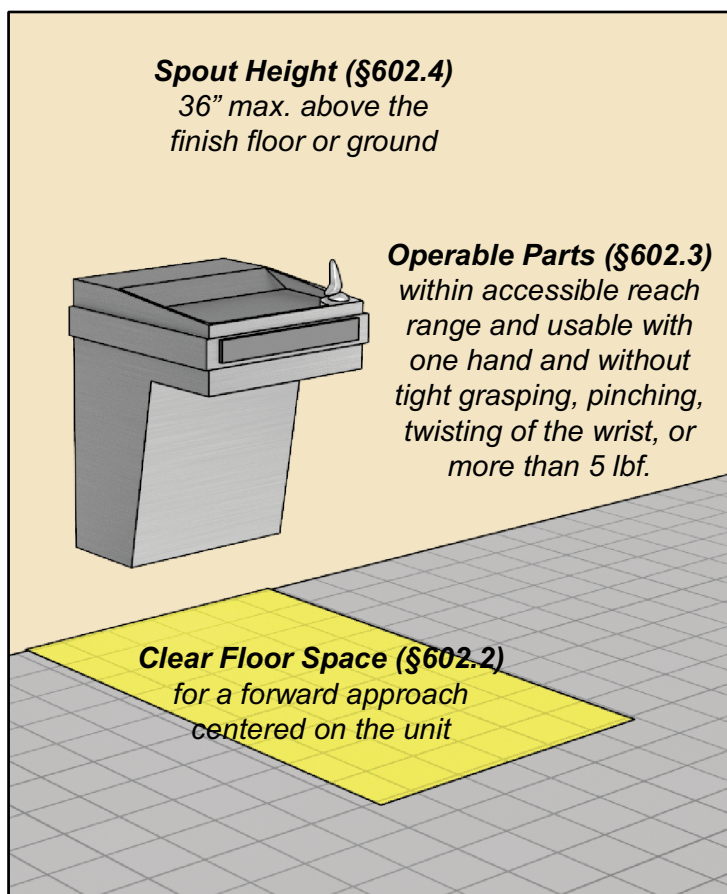

**Water Flow (§602.6)**  
The water flow must be 4" high min. The maximum angle of the water stream is based on the distance of the spout from the front of the unit.

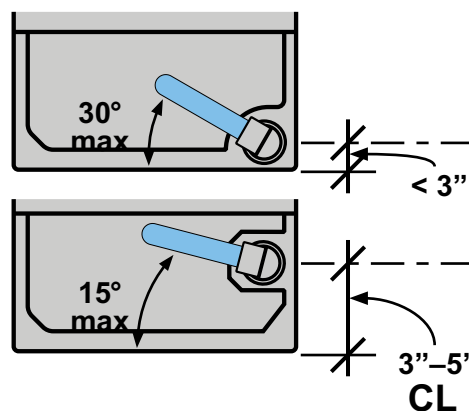

## Spout Location (§602.5)

Spouts must be 15" min. from the vertical support and 5" max. from the unit's front edge, including bumpers.

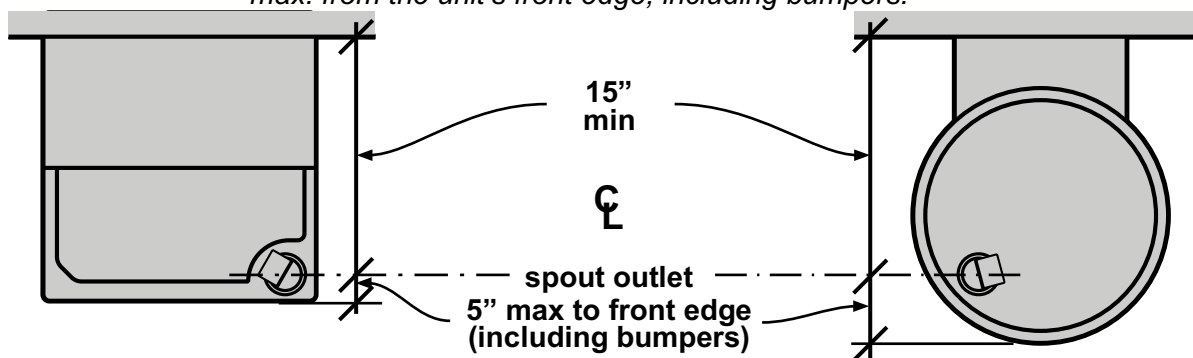



## Clear Floor or Ground Space [§602.2, §305]

Clear floor or ground space for a forward approach must be centered on the unit.

Additional clearance is required if the space is obstructed on both sides for more than half the depth, such as at alcoves.

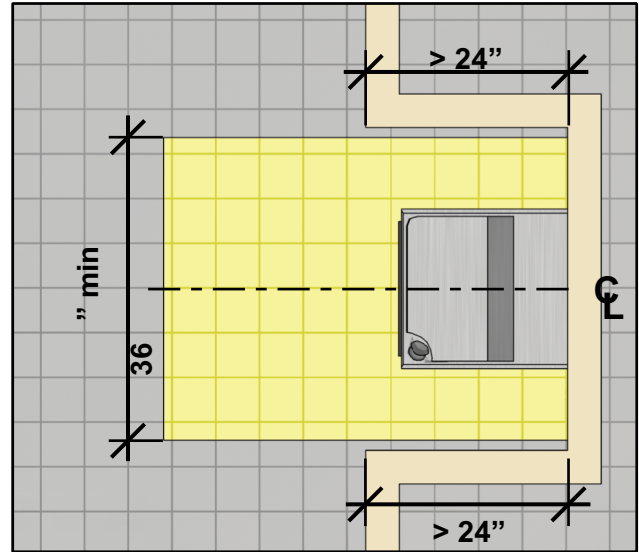
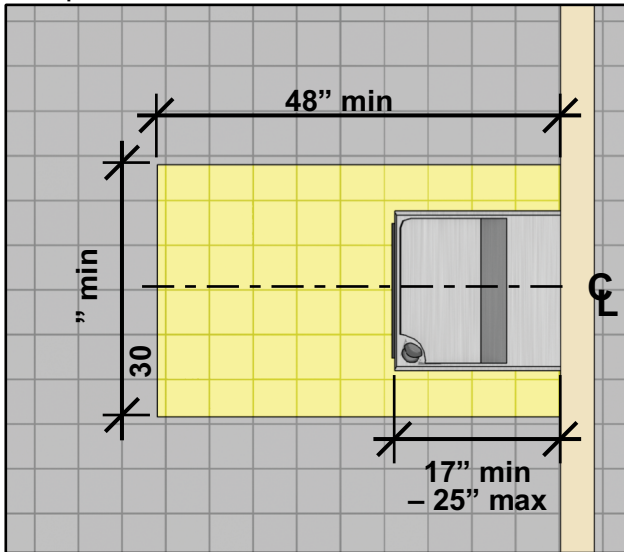

Knee and toe space is required below the unit. The combined depth of the knee and toe space must be at least 17" (and 25" max.) measured from the leading edge of the unit, including bumpers.

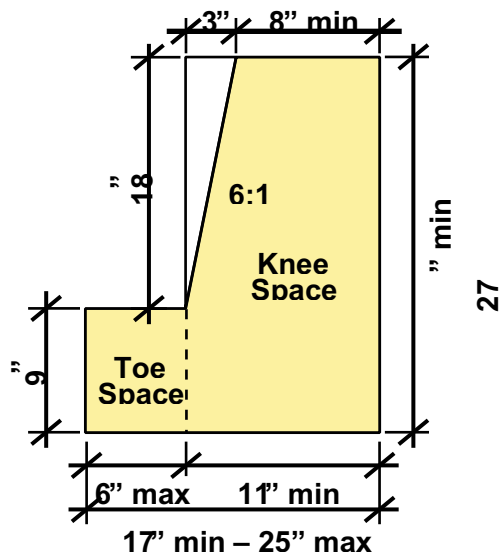
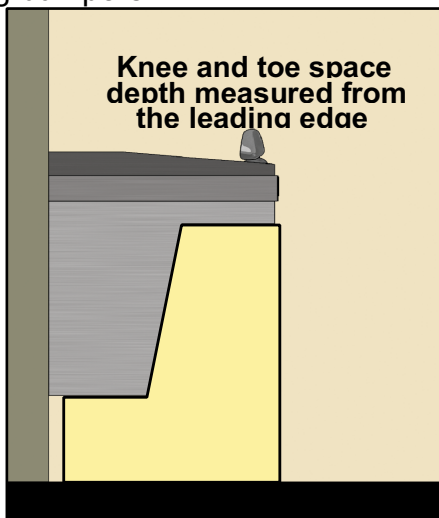

## Drinking Fountains for Children's Use [§602.1 – §602.6]

Drinking fountains designed specifically for children ages 12 and younger can provide a parallel approach instead of a forward approach if the spout is 30" high max. and no more than 3½" from the front edge of the unit, including bumpers (§602.2, Ex). Parallel clear floor space is not required to be centered on the unit.

### Children's Drinking Fountain

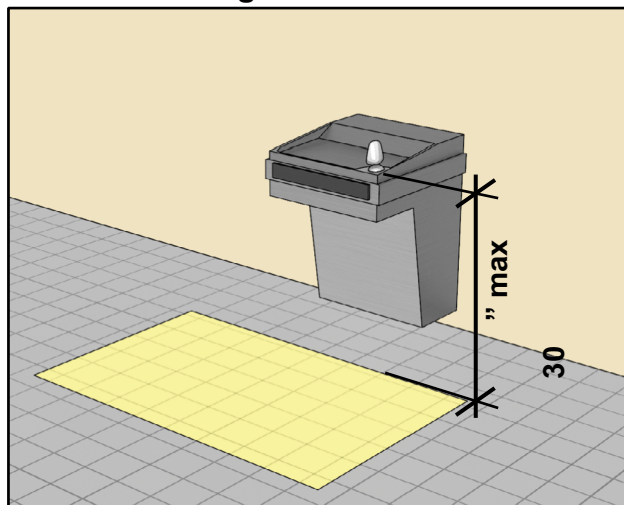
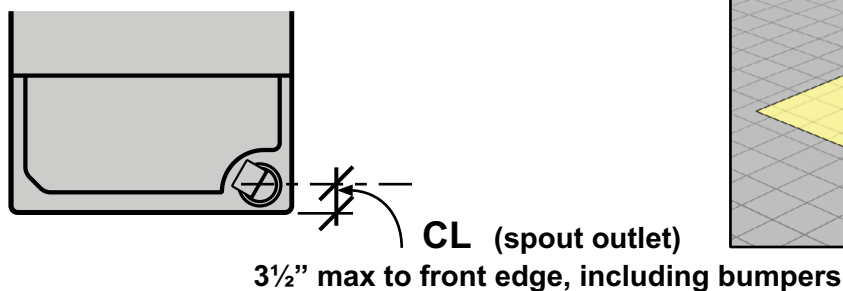

## Drinking Fountains for Standing Persons [§602.7]

Drinking fountains for standing persons must have spouts 38" to 43" high and compliant operable parts and be located on an accessible route. They cannot obstruct the forward approach clearance, including knee and toe space, required at wheelchair accessible units.

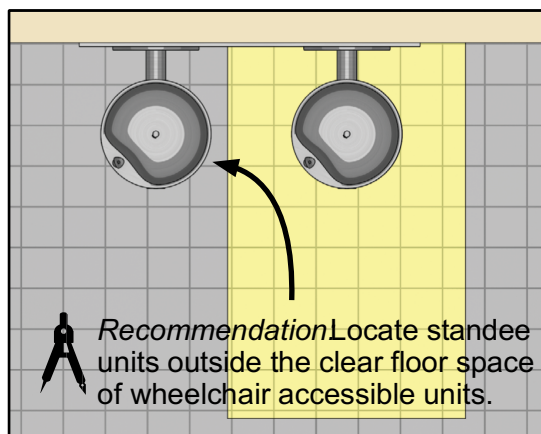
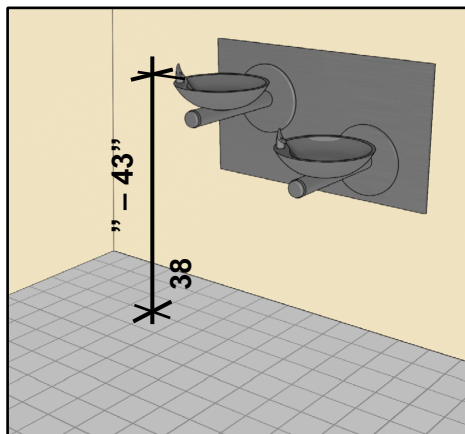

*Recommendation:* Although cantilevered units for standing persons with knee and toe space can overlap the clear floor space of adjacent wheelchair accessible units, it is better to locate them outside this clear floor space so that they do not impact access to low units.

## Drinking Fountains as Protruding Objects [§602.1, §307]

Requirements for protruding objects (§307) apply to drinking fountains. Drinking fountains with leading edges higher than 27" must be recessed in alcoves or otherwise treated so that they do not protrude more than 4" into circulation paths. Alcoves must be sized to accommodate the clear floor space required at wheelchair accessible units.

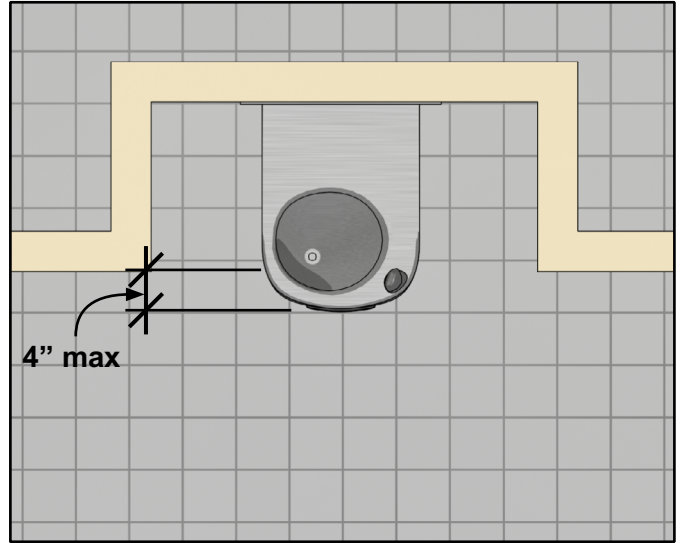
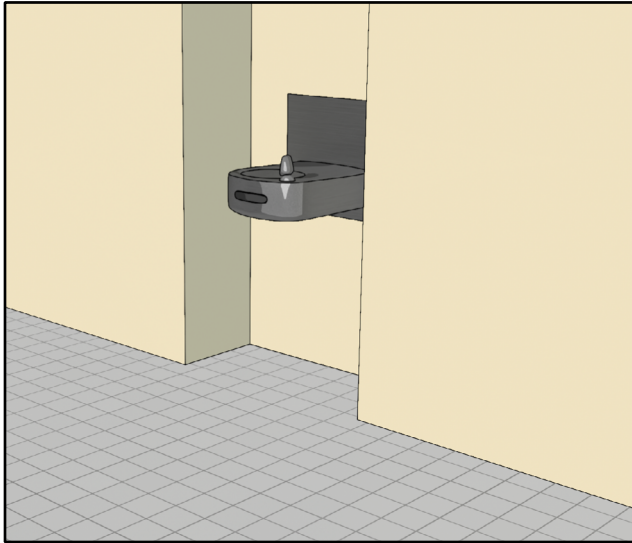

Wheelchair accessible units that provide, but do not exceed, the 27" minimum knee clearance do not require treatment as a protruding object because the leading edge is at the maximum limit for cane detectability. Such units can be used to enclose one side of cantilevered units for standees. Other fixed objects, such as benches and planters, can be used to recess drinking fountains.

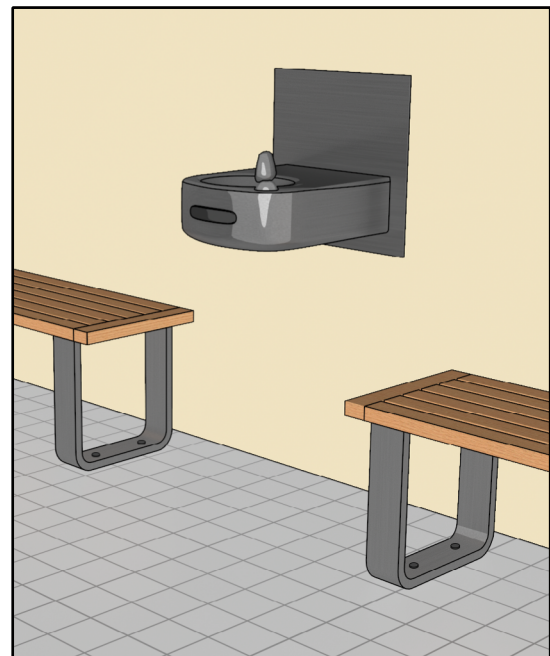
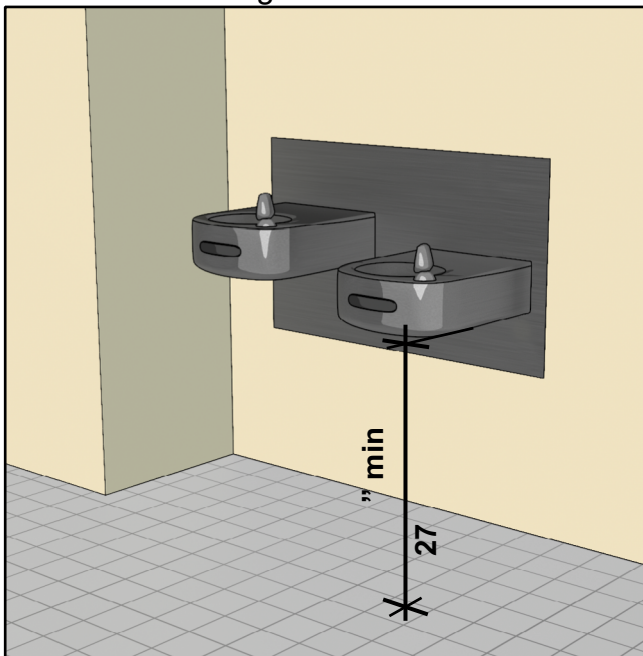

## Common Questions



*Can water coolers or bottle fillers substitute for accessible drinking fountains?*

If drinking fountains are provided, water coolers or bottle fillers cannot be used as a substitute for either a wheelchair accessible unit or a unit for standees in new construction, alterations, or additions. Water coolers and bottle fillers can be provided in addition to, or be integrated with, drinking fountains. If no drinking fountain is provided, a compliant drinking fountain is not required even if water coolers or bottle fillers are provided. Water coolers and bottle fillers that are fixed or built-in must comply as operable parts (§205, §309) but are not subject to other requirements for drinking fountains.

*When must drinking fountains be designed for use by children?*

The Standards do not specify where units must be mounted or designed specifically for children. This determination is left to other building codes or regulations, good practice, client preference, or other factors. Instead, the Standards provide an exception that can be used when the decision is made to mount drinking fountains at heights for children ages 12 and younger. Under this exception, a parallel approach is permitted instead of a forward approach with knee and toe clearance in order to accommodate a lower unit height provided that the spout is no higher than 30" and no more than 3½" from the front edge of the unit, including bumpers (§602.6).

*Do drinking fountains have to meet requirements for protruding objects?*

Yes, the Standards limit the protrusion into circulation paths of those objects, including drinking fountains that have leading edges higher than 27" above the finish floor or ground. Cantilevered units with leading edges higher than 27" must be recessed or protected as protruding objects. Wheelchair accessible units with a 27" absolute knee clearance below do not require treatment as protruding objects.

*Can units for standees overlap the clear floor space required at wheelchair accessible units?*

Units for standing access (or other elements) that do not have compliant knee and toe clearance cannot overlap or protrude into the clear floor space at adjacent wheelchair accessible units. Cantilevered units for standees with compliant knee and toe space can overlap the clear floor space at wheelchair accessible units but it is advisable to locate them outside the clearance since they can interfere with use of the lower unit when located in close proximity.

# Stairways



This guide explains requirements in the ADA Standards for stairways.

## **Required Compliance [§210]**

Interior and exterior stairs that are part of a required means of egress must meet the Standards. Compliance is required for all stairs on required egress routes, including those comprised of a single riser. The Standards do not apply to stairways that are not part of a required means of egress nor to alternating tread devices and “ship’s ladders.” The Standards exempt aisle stairs in assembly areas, stairs in non-public areas of detention and correctional facilities, and stairs of play components.

*Stairs that are part of a required means of egress must comply.*

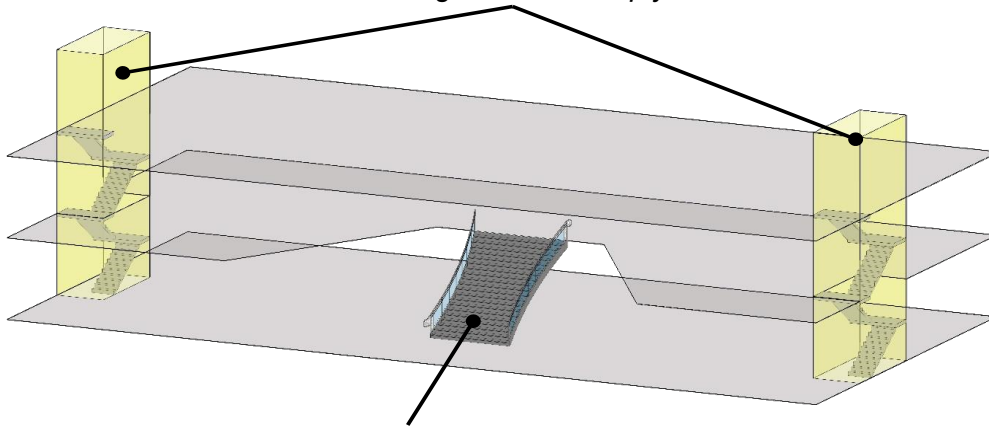

*Compliance is not required for monumental stairs and other stairs if they are not part of a required means of egress.*

*Stairs that are part of exit discharge or other components of a means of egress must comply.*

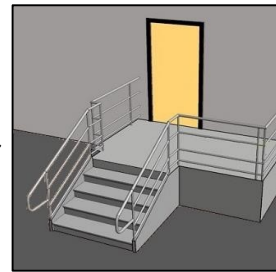

### **Alterations**

In alterations, stairs between levels that are connected by an accessible route (e.g., ramp or elevator) are not required to meet the Standards, but handrails must comply when stairs that are part of a means of egress are altered (§210.1, Ex. 2).

### **Stairways [§504]**

Requirements for stairways address treads and risers, surfaces, nosings, and handrails.

#### ***Treads and Risers (§504.2 and §504.3)***

*All steps on a flight must have uniform riser heights within a range of 4" – 7" and uniform tread depths that are 11" min. Open risers are prohibited.*

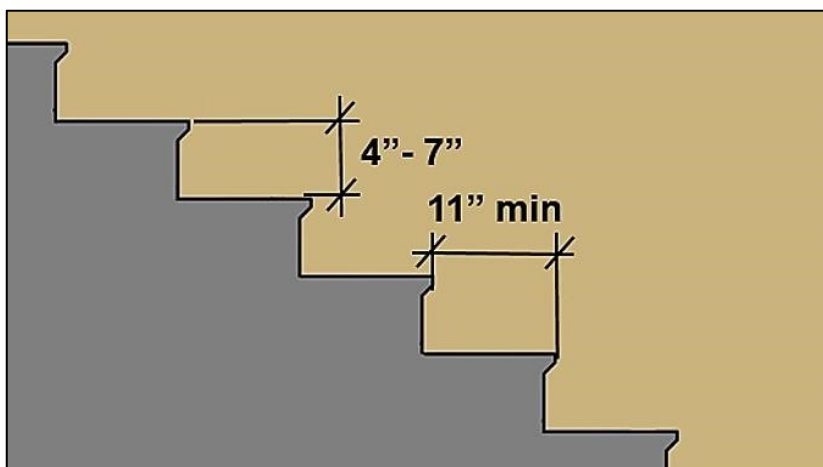

#### **Tread Surface and Wet Conditions (§504.4 and §504.7)**

Tread surfaces must comply with requirements for ground and floor surfaces (§302) and cannot have changes in level other than slopes not steeper than 1:48. Treads and landings subject to wet conditions must be designed to prevent the accumulation of water.

#### **Nosings (§504.5)**

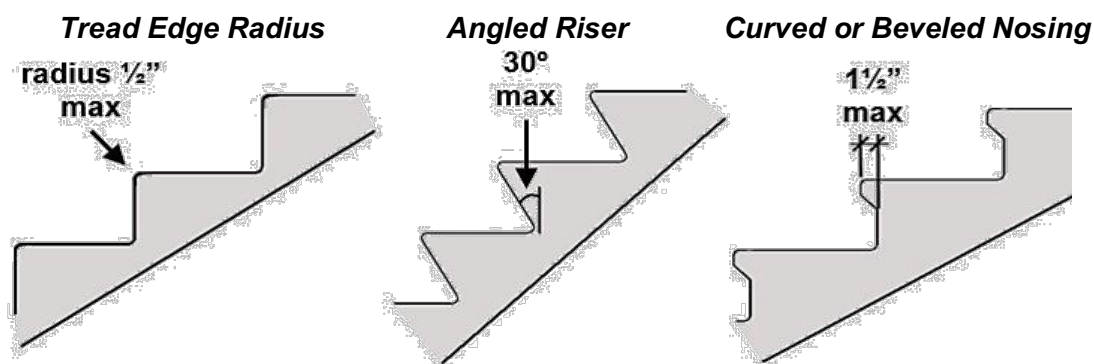

The radius of curvature at the leading edge of the nosing cannot exceed 1/2 inch. Risers can slope under the nosing at an angle not exceeding 30° from vertical. Nosings cannot project more than 1 1/2 inches over the tread, and the tread must be 1/2 inch max. The underside of the leading edge of the nosing must be curved or beveled.



**Recommendation:** Providing visual contrast (light-on-dark or dark-on-light) on the top and bottom steps that is approximately 2 inches wide and located either on nosings or at the leading edges of treads is helpful for people with low vision.

#### **Handrails [§504.6, §505]**

Handrails are required on both sides of stairs and must be continuous within the full length of each stair flight. Inside handrails on switchback or dogleg stairs must be continuous.

### Stairway Handrails

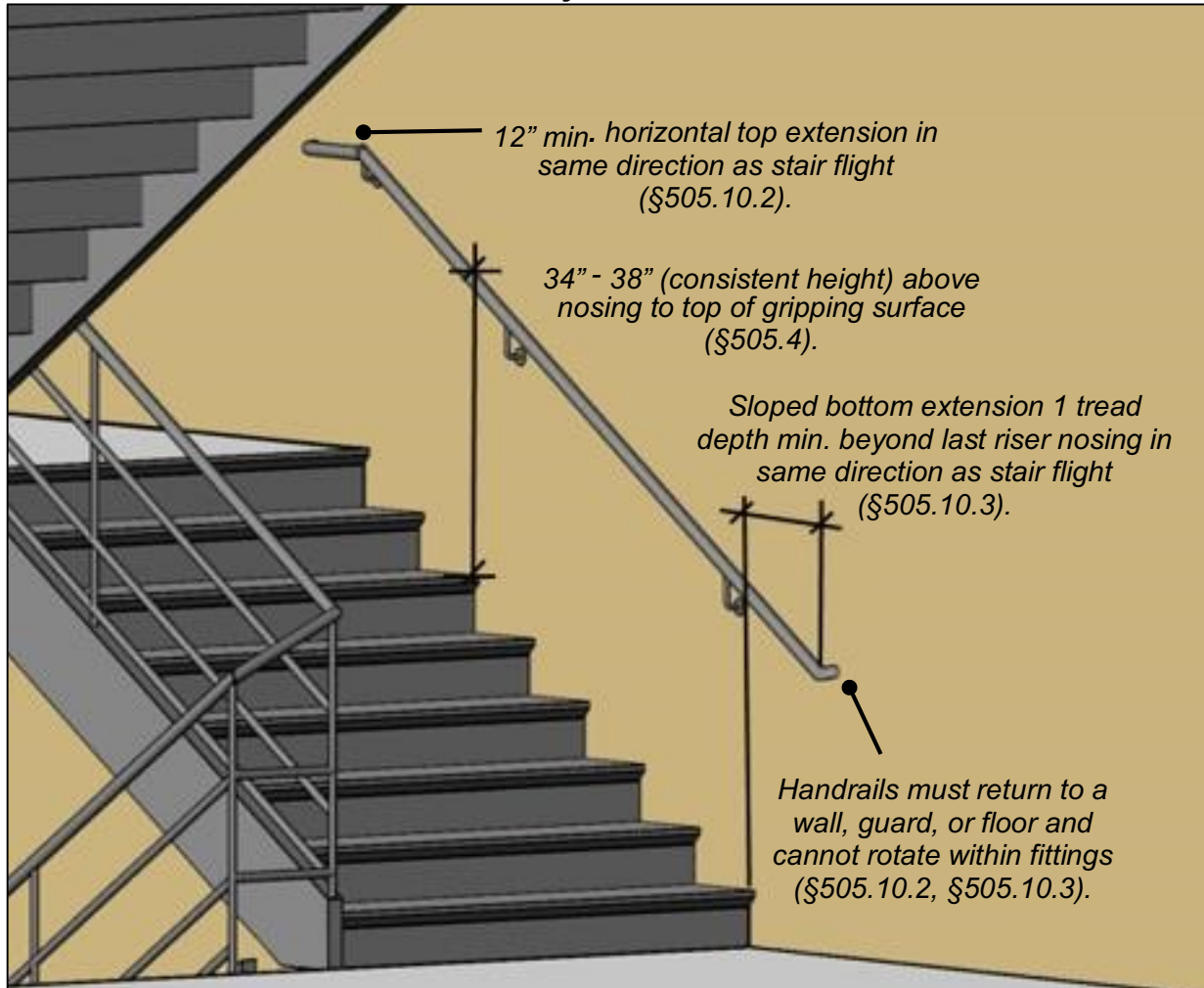

Inside handrails at switchback/dogleg turns must be continuous (extension not required) (§505.3).

Top and sides of gripping surface cannot be obstructed; bottom can be obstructed up to 20% of the length (§505.6).



In alterations, full handrail extensions are not required where they would project into circulation paths and pose a hazard (§505.10, Ex. 3).



**Recommendation:** In facilities that primarily serve children, a second set of stairway handrails 28" high maximum above stair nosings is advisable. A vertical clearance 9" minimum between upper and lower handrails will help prevent entrapment.



## Handrail Extensions [§505.10]

Handrail extensions at the top and bottom must return to walls, guards, or floors and horizontal portions must comply as protruding objects. The length is measured to the start of the return radius.

*Top Handrail Extension*

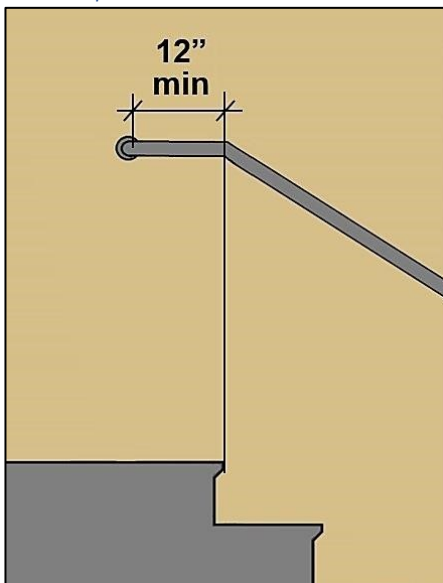

*Handrails at the top of stairways must extend 12" minimum horizontally above the landing beginning directly above the first riser nosing or be continuous to the handrail of an adjacent stair flight (§505.10.2).*

### *Extensions as Protruding Objects*

*Objects mounted on posts with leading edges higher than 27" cannot protrude into circulation paths more than 12" (§307.3). With handrails, this applies only to horizontal portions, not sloped portions. Horizontal top extensions that return to posts can protrude any amount if the leading edge is 27" max. above the finish floor or ground.*

*Bottom Handrail Extension*

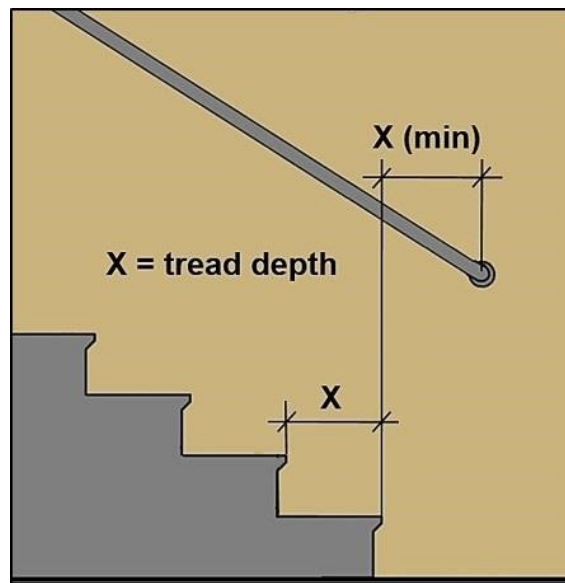

**Recommendation:** Treat freestanding bottom extensions as protruding objects if they have leading edges higher than 27".

*Handrails at the bottom must extend beyond the last riser nosing at the slope of the stair flight for a distance at least equal to one tread depth or be continuous to the handrail of an adjacent stair flight protruding objects.*

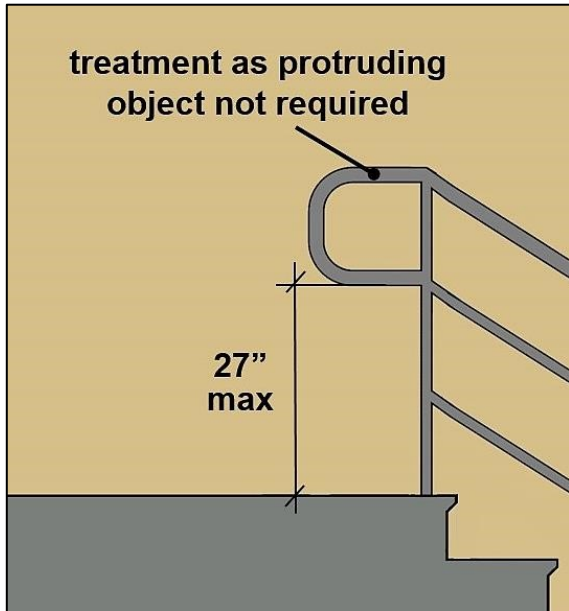

**Handrail Clearance and Cross Section [§505.5, §505.7]**

Surface requirements and clearances facilitate a power grip along the length of handrails. Handrails can have circular or non-circular cross-sections, but must have rounded edges. The gripping surface and adjacent surfaces must be free of abrasive or sharp elements. Wall-mounted handrails with leading edges higher than 27" cannot protrude more than 4½" into circulation paths (§307.2).

**Circular Cross Section and Clearance**

*Specifications for handrails also address the diameter of circular cross sections and required knuckle clearance.*

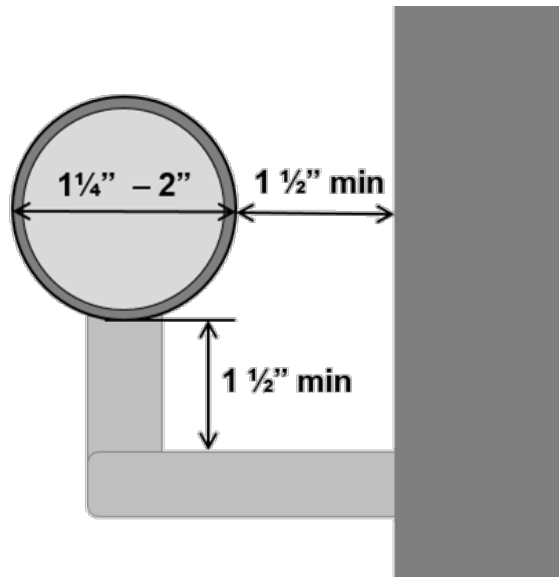

**Non-Circular Cross Section and Clearance**

Non-circular cross sections must have rounded edges and meet perimeter and

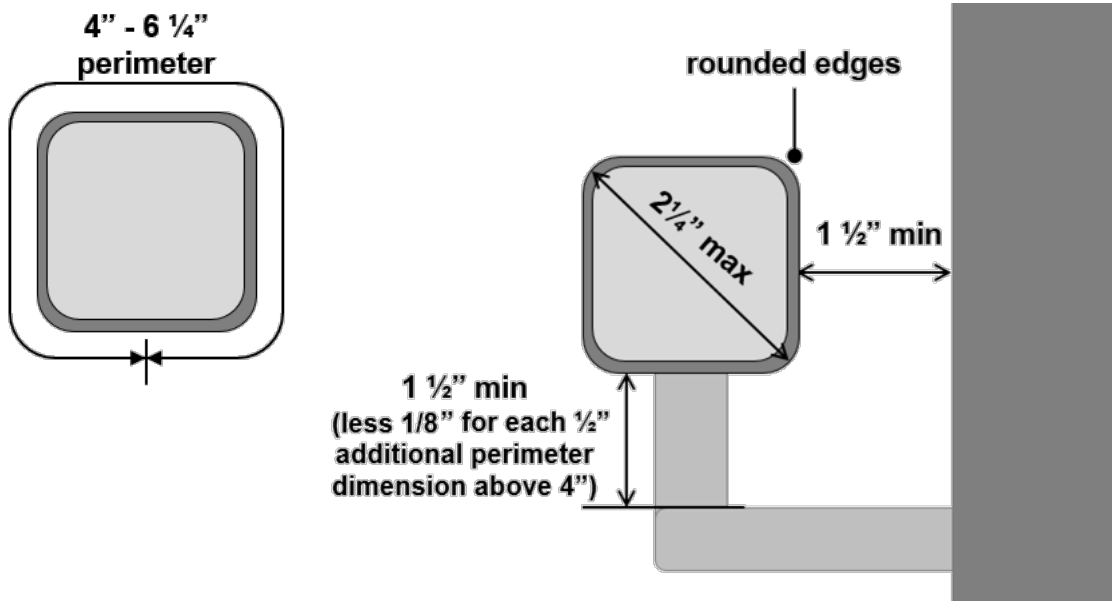

cross-section dimensions. Other profiles meeting these criteria are permitted.



**Recommendation:** Projecting objects above handrails can impact their usability. Keep wall surfaces above handrails free of any protrusions.

### Escalators

The ADA Standards address escalators in rail and fixed guideway stations (§810.9) but not those provided in other types of facilities. Escalators must have a clear width of at least 32" and meet specific provisions in the ASME A17.1 Safety Code for Elevators and Escalators. The referenced ASME criteria require steps to be demarcated by yellow lines 2" wide maximum along the back and sides (§6.1.3.5.6) and specify at least 2, but no more than 4, flat steps at escalator entrances and exits (§6.1.3.6.5).



**Recommendation:** Apply the requirements for escalators in rail and fixed guideway stations to escalators provided in other types of facilities.



## Common Questions

*Are stairs that are not part of means of egress required to comply with the Standards?*

No, interior or exterior stairs that are not part of a required means of egress do not have to meet the Standards.

*Are exterior stairs required to comply with the Standards?*

The Standards apply to both exterior and interior stairs that are part of a required means of egress. This includes exterior stairs that are part of exit discharge (i.e., the path from an exit to a public way such as a street or alley).

*Is there a minimum number of risers a stairway must have for it to be covered?*

No, the Standards apply to any stairs that are part of a means of egress regardless of the number of risers.

*Are stairs in residential dwelling units covered by the Standards required to comply?*

Yes, stairs that are part of a means of egress must comply in mobility accessible residential dwelling units covered by the Standards. Egress stairs of residential facilities that are located outside individual dwelling units also must comply.

*Can stair treads and risers be perforated?*

Stair treads must meet requirements for floor or ground surfaces which specify that surface openings not allow passage of a sphere more than ½ inch in diameter (§302.3). Risers cannot be open, but perforations or openings in riser surfaces that prohibit passage of a sphere not more than ½ inch in diameter are acceptable.

*Can handrail extensions wrap or turn?*

Handrail extensions must be in the same direction as the stair flight, but continuous handrails can wrap at the inside turn of switchback or dogleg stairways. In alterations where the required extension would project into circulation paths and pose a hazard, they can turn, wrap, or be shortened as necessary.

*Can handrails overlap door maneuvering clearances?*

No, door maneuvering clearances must be free of any overlapping objects, even those providing knee and toe clearance, which can interfere with maneuvering at doors and doorways. However, door maneuvering clearances can be offset up to 8" from the face of the door or gate to accommodate wall thickness, casework, shelves, or other elements adjacent to doorways, including handrails. The door

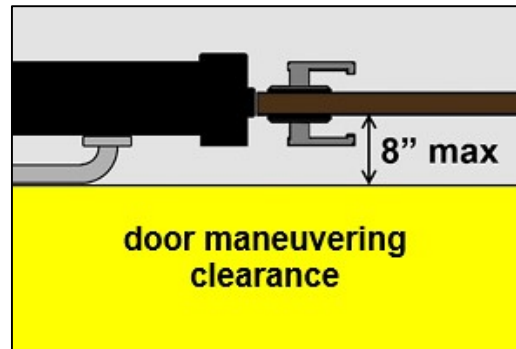

maneuvering clearance must be *Handrails and other elements cannot overlap the door maneuvering clearance elements so that the full clearance is free but can be located within the 8" max. of any obstruction. offset from the face of the door.*

*Can handrails be attached to guard rails?*

Yes, handrails can be installed on guard rails if all applicable requirements are met.

*Is a center handrail required at wide stairways?*

No, a center handrail at stairs is not required by the Standards. If a center handrail is provided, compliance with the handrail specifications, while advisable, is not required.

*Is color contrast required for stair nosings?*

Visual contrast on stair nosings or the leading edges of treads is helpful for people with low vision, but it is not required by the Standards except at escalators in rail and fixed guideway stations which must meet the ASME A17.1 Safety Code for Elevators and Escalators. The ASME A17.1 code requires escalator steps to be demarcated by yellow lines 2" wide maximum along the back and sides.

*Can guards or collars be attached to handrails to prevent skateboard traffic?*

No, handrail gripping surfaces at egress stairs subject to the Standards must be unobstructed on the top and sides and free of sharp or abrasive elements so that users can maintain a continuous grip along the full length (§505.6 and §505.8).