



Natural Site Design Preservation and Protection



8

Professional Development Hours (PDH) or

Continuing Education Hours (CE)

Online PDH or CE course

Contact information

www.DiscountPDH.com

fdapdh@gmail.com

Telephone: 713-787-6810

Corporate Mailing address:

2500 Tanglewilde, Suite 220

Houston, Texas 77063

For all your questions and instructor support please contact us via email or phone.

All emails and phone calls are addressed within 24 hours.

Operating hours: 9 am – 4 PM central time

Tel: 713-787-6810

Fax: 713-787-6825

Email: fdapdh@gmail.com



Planning Principles & Design Considerations

Planning Principles & Design Considerations	4
Preservation & Protection – Natural Site Design.....	6
Preservation of Natural Vegetation.....	7
Riparian Buffer Zones.....	9
Wetlands	13
Floodplains.....	15
Steep Slopes	17
Karst.....	19
Land/Site Utilization	23
Soil Properties	25
Reduce Limits of Clearing & Grading.....	29
Fit the Design to the Existing Terrain.....	33
Utilize Undisturbed Areas & Natural Buffers	35
Planning Principles	37
Creative Development Design	39
Roadway Design	43
Building Footprints	47
Parking Lot Footprints	49
Setbacks & Frontages.....	53
Natural Drainageways vs. Storm Sewers.....	55

Above photo source:
Natural Resources Conservation Service, Iowa

PLANNING PRINCIPLES & DESIGN CONSIDERATIONS

Project planning, design, and layout can begin once all site information and data has been collected and analyzed. The first step in planning, design, and layout is to develop a set of construction plans including a comprehensive site plan.

A site plan is a graphical depiction showing the layout of a project. Site plans typically include the location, design, and specifications for roads, streets and parking areas; storm water management systems, wastewater management systems, utilities, and other infrastructure; structures; landscaping and common areas; and other facilities associated with the project.

Development of the site plan should take into consideration all of the information collected during the site assessment and data collection process. When making planning, design, and layout decisions, it is extremely important to take advantage of the strengths and overcome the limitations of project site features identified in the assessment process. Adapting a plan design to existing site conditions and the natural features of the landscape can greatly reduce the project's environmental impacts.

Storm water management, including erosion and sediment control and post-construction pollution prevention measures, needs to be an integral part of the site planning process and not just an afterthought. Again, it is extremely important to take into consideration details for land clearing, grading, and cut and fill operations that will be used during the construction process when developing the site plan. Therefore, the best approach to developing a set of comprehensive construction plans is to prepare the site plan and storm water pollution prevention plan simultaneously.

This section contains several basic planning principles and design considerations that should be reviewed and incorporated into the site planning process whenever possible. Using these principles and design considerations will help reduce environmental impacts and minimize project construction costs.

The following illustrations show a comparison of conventional design versus a design that incorporates planning principles and consideration for the natural site features.

PLANNING PRINCIPLES & DESIGN CONSIDERATIONS

Conventional Design



Source: Georgia Stormwater Management Manual, 2001

Improved Site Design

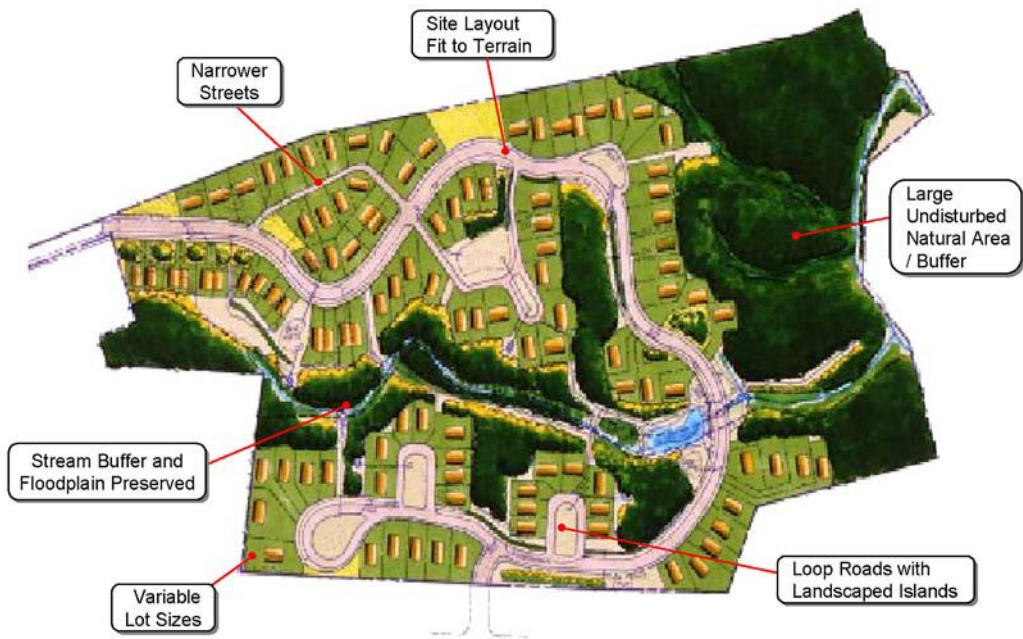

Source: Georgia Stormwater Management Manual, 2001

PRESERVATION & PROTECTION—NATURAL SITE DESIGN

One of the first activities that should be performed at a project site is a site assessment of resource issues. This process includes inventory and data collection of the resources that are associated with the project site. This process is described in more detail in Chapter 2 of this manual.

This section provides an in depth discussion of key natural features that may be encountered at a project site. The intent of this section to provide an understanding of each of these resource features and issues with an emphasis on protection. Incorporating these natural features into the design and layout of the project site can minimize the overall impact of the project. Benefits include but are not limited to a reduction of impervious surfaces, decreased generation of pollutants, and treatment of storm water runoff.

PRESERVATION & PROTECTION—NATURAL SITE DESIGN

Preservation of Natural Vegetation



The preservation of natural vegetation during construction provides natural buffer zones, protects soils from water and wind erosion, removes sediments and other pollutants from storm water runoff, and is aesthetically pleasing. This technique can be applied to all types of sites.

Key Benefits

- Vegetation absorbs the energy of falling rain.
- Dense root structures hold soils in place and increase the soil's absorptive capacity.
- Plant roots hold soil particles in place and preserve and promote development of soil structure, resulting in increased soil permeability which increases the soil's ability to absorb storm water runoff.
- Vegetation also:
 - Slows the velocity of runoff and acts as a filter to trap sediment.
 - Serves as a buffer zone against noise.
 - Enhances aesthetics of the area.
 - Provides areas where wildlife can remain undisturbed.
 - Provides a source of shade during summer months.
 - May add to the value of residential and commercial properties.
 - Usually requires less maintenance than planting new vegetation.

Planning Consideration

- Extremely well-suited for use in areas prone to high rates of soil erosion where other soil erosion control measures would be difficult to establish, install, or maintain.
- Use in areas where it is desirable to reduce storm water runoff sheet flow velocities.
- Can be used to protect unique or endangered plant species.

PRESERVATION OF NATURAL VEGETATION

Discussion

Soil erosion is a leading cause of water quality problems in Indiana. It impacts water quality by degrading the habitat of aquatic organisms and fish, promotes the growth of nuisance weeds and algae, and decreases its recreational value. During construction, if disturbed land is left unprotected its erosion potential increases, storm water runoff volumes and sediment loadings increase, and the potential for surface water degradation increases.

The preservation of vegetation should be planned before any site disturbance begins. Planners should note the locations where vegetation should be preserved and consider this when determining the location of roads, buildings, or other structures. Highly visible barricades and signs should be erected to protect vegetation boundaries selected for preservation. Preventing damage is less costly than correcting it.

Planning should include the maintenance requirements of the existing vegetation. Based on soil types and climate, different species will require different maintenance activities such as mowing, fertilization, irrigation, pruning, and weed/pest control. These activities should be performed regularly during construction.

PRESERVATION & PROTECTION—NATURAL SITE DESIGN

Riparian Buffer Zones



Source: Natural Resources Conservation Service, Iowa

Riparian buffer zones are natural vegetative zones along creeks, streams, channels, or other waterbodies. They typically consist of tree, shrub, and grass plantings.

Key Benefits

- Riparian buffer zones help:
 - Maintain the integrity of stream channels and shorelines.
 - Remove pollutants such as suspended solids, phosphorous, nitrates, trace metals, pesticides, and hydrocarbons from storm water runoff.
 - Remove nutrients and other pollutants from subsurface flow through filtering and plant uptake.
- Riparian buffer zones supply food, cover, and shade (thermal protection) to fish and other wildlife.
- Riparian buffer zones provide:
 - Green space and wildlife corridors.
 - Recreational areas such as parks and walking trails.

Planning Consideration

- Use along fields, housing developments, industrial and commercial sites, etc. where it is desirable to protect streambanks and drainage channels and to decrease nonpoint source pollution of waterbodies.
- Can be used along streams and drainage channels where it is desirable to preserve native vegetation and buffers both during and after active land-disturbing activities.
- Well suited for setting aside areas for wildlife food and habitat.

RIPARIAN BUFFER ZONES

Discussion

Riparian buffer zones are typically found connecting a stream system and a people-based system such as agriculture, housing, or industry. From the water's edge and continuing up slope, the area can be viewed in zones. The "three-zone buffer concept" is the most common type of riparian buffer zone system. Zone 1 is a mix of undisturbed, native trees and provides bank stabilization as well as shading and protection for the stream. This zone may also include wetlands and any critical habitats. Zone 2 is a transition zone consisting of native trees, shrubs, and grasses. This area can be used for various purposes such as timber harvesting, wildlife habitat, and outdoor recreation. Zone 3 consists of a dense mixture of grasses and forbs (broad-leaved herbaceous plants and wildflowers). This zone acts as a further setback between the waterbody and impervious surface areas. It provides more permeable surface area for infiltration of storm water runoff into the soil. The vegetation in this zone also helps convert concentrated storm water runoff into sheet flow, maximizing surface area for infiltration of runoff.

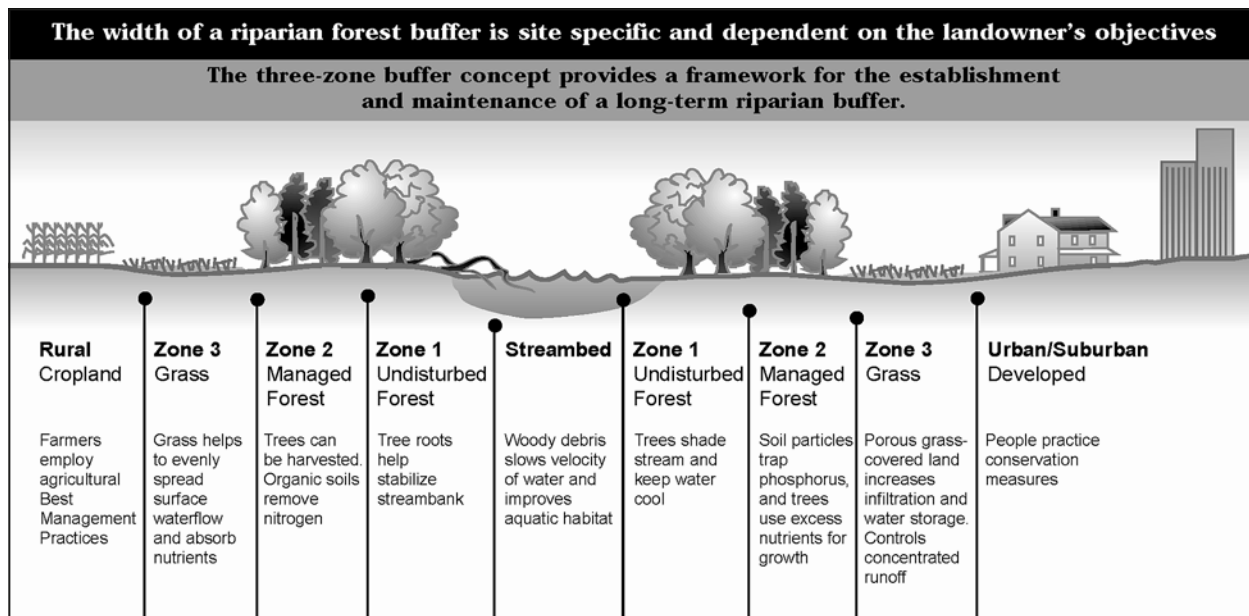

Source: Maryland Cooperative Extension, Fact Sheet FS724, 1998

Riparian buffer zones are very important in minimizing nonpoint source pollution of waterways from adjacent land, protecting aquatic environments, enhancing wildlife habitat, and increasing biodiversity. The roots of riparian vegetation also help stabilize streambanks and shorelines and therefore are important in minimizing streambank and shoreline erosion potential.

RIPARIAN BUFFER ZONES

During construction of a project, riparian buffers that are to be preserved should be protected from excessive sediment loads by installing appropriate erosion and sediment control measures.

In general riparian buffer zones should be kept in their natural state. However, some upkeep such as planting to minimize concentrated flow, removal of exotic species, and removal of damaged or diseased trees may be necessary.

Installation of riparian buffer zones on agricultural lands should take into consideration the location of crop lands, grazing lands, livestock enclosures, and pasture lands. Developments along stream channels and drainageways in urban areas should utilize riparian buffers whenever feasible to protect the stream from nonpoint source pollution and provide for community recreational use. Urban riparian buffers should have easements allowing for protection and maintenance of the vegetation. Urban riparian buffer zones can also be an effective selling point when landowners want the benefits a buffer can provide or where a high level of benefit can be derived at an acceptable cost to the landowner and the public.

This page was intentionally left blank.

PRESERVATION & PROTECTION—NATURAL SITE DESIGN

Wetlands



Wetlands are areas that are saturated by surface water or ground water for extensive periods of time and have the ability to support water-loving plants as a result of hydric soil conditions.

Key Benefits

- Wetlands help remove excess nutrients and trap sediments and other pollutants contained in storm water runoff via infiltration, absorption, ion exchange, precipitation, and biodegradation thereby preventing pollutants from reaching rivers, lakes, and other waterbodies.
- Wetlands help slow and absorb flood waters.
- Wetlands provide habitat for thousands of species of aquatic and terrestrial plants and animals.

Planning Consideration

- Well suited for use in areas designated to be set aside for the preservation of plant and animal life and biodiversity.
- Can be used in areas where it is desirable to capture storm water runoff and allow ground water recharge.
- May be used to reduce flooding potential.
- Consider limited capacity for handling increased flows and pollutant loadings.
- Natural wetlands should not be used as a primary treatment measure to capture pollutants; consider pretreatment.

WETLANDS

Discussion

Wetlands serve important water quality improvement functions within the landscape. They are a major link between land and water. One of the functions performed by wetlands is the filtering of nutrients such as phosphorous and nitrogen. Due to their unique position in the landscape, wetlands serve as natural receptacles for storm water runoff and can absorb enough water to help control flooding. Wetlands also have the ability to soak up storm water runoff during storms and then slowly release the water over extended periods of time.

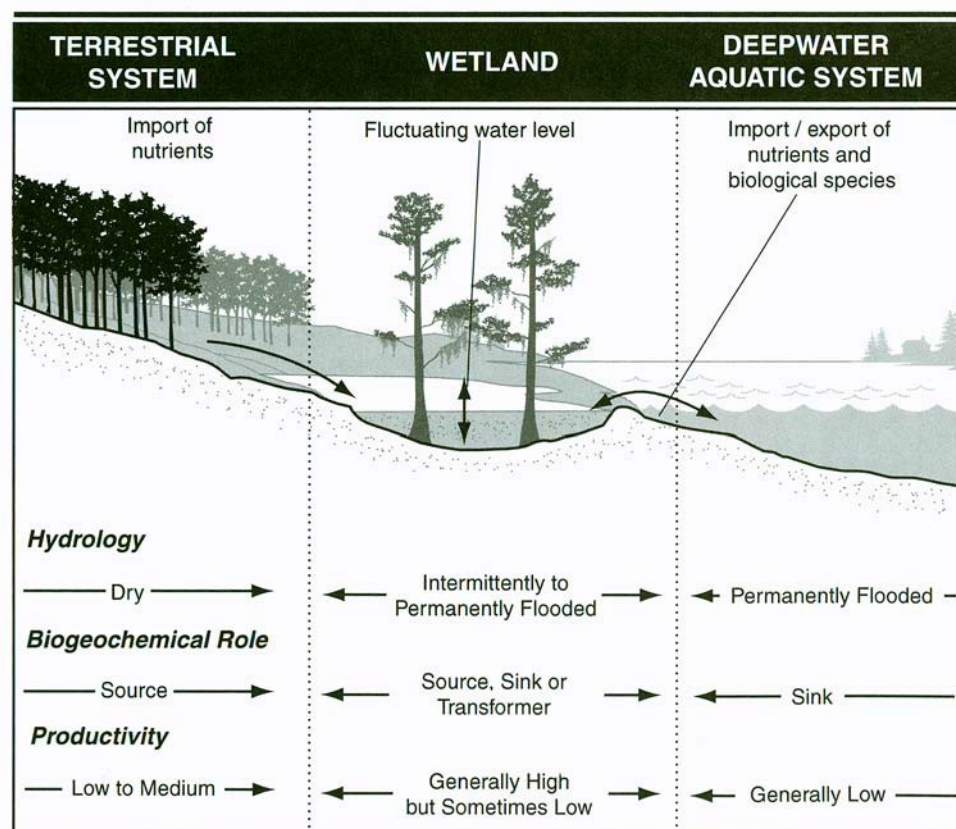

Source: Adapted from *Wetlands*, 3rd Ed., 2000 by Mitsch, William J. and Gosselink

The above functions should be taken into consideration when developing storm water management strategies for lands undergoing land use changes. However, when considering diverting flows to a wetland (either from storm water sources or non-storm water sources), it is important to consider that they do have a limited capacity for handling increased flows or additional pollutant loadings. In urban areas wetlands are dramatically altered by uncontrolled runoff, either through natural drainage to those systems or direct discharge.

PRESERVATION & PROTECTION—NATURAL SITE DESIGN

Flood Plains



Flood plains are areas consisting of drainage channels and adjoining dry land areas that are susceptible to being inundated by water from any natural source.

Key Benefits

- Flood plains provide a natural right-of-way and temporary storage for large flood events.
- Flood plains protect people and structures from flood water harm and damage.
- Flood plains help preserve riparian ecosystems and habitats.
- Flood plains may be used in conjunction with riparian buffer zones to create linear greenways.

Planning Consideration

- Consider using in areas where there is a need to protect humans or structures from flood water harm or damage.
- Use where it is desirable to preserve aquatic and terrestrial habitats and biodiversity.

Discussion

A flood plain consists of a stream or drainage channel and low-lying areas bordering the stream or channel. When the stream or channel reaches its capacity after a heavy rain or a significant snow melt event, the channel overflows into the flood plain. This makes flood plains very beneficial because of their storage and conveyance capacity and ability to reduce the volume and velocity of flood waters. By reducing flood water volumes and velocities, flood

FLOOD PLAINS

plains have the added benefit of allowing for the settlement and removal of sediments and other suspended solids commonly found in storm water runoff. Flood plains are also very important to the survival of aquatic and terrestrial life and preservation of biodiversity.

Streams and other water-courses should be allowed to naturally flow through their own corridors. When development encroaches on a flood plain, its ability to convey storm water is greatly reduced and the potential for human or structural harm is elevated.

Most communities regulate the use of flood plains in order to avoid these

risks. Ideally the 100-year flood plain should be avoided for clearing and building. The best case scenario is one in which the entire 100-year flood plain is left in a natural state. Many times this area coincides with the riparian stream buffer. Both practices preserve the stream corridor in its natural state and protect existing wildlife habitat and vegetation. The boundaries of the 100-year flood plain may lie within or outside the riparian stream buffer zone.

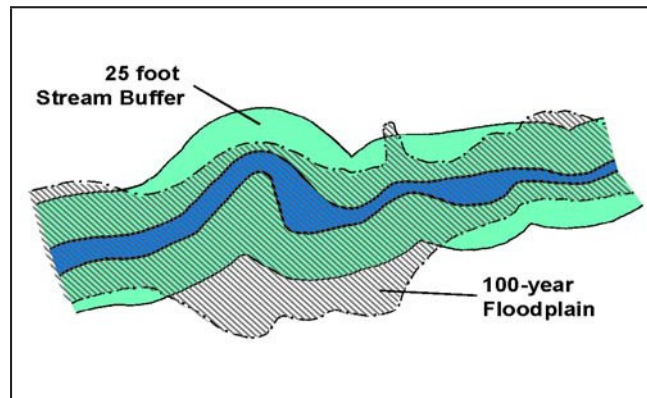

Source: Georgia Stormwater Management Manual, 2001

Maps of 100-year flood plains are generally available through local planning, zoning, or building departments. It is important to note that developers and building designers must comply with Federal Emergency Management Agency requirements.

Flood plains are often inconspicuous on smaller conveyance systems, but they serve the same function as flood plains on larger creeks, streams, and rivers. To maintain the integrity and function of flood plains, construction activities and the placement of fill materials in the flood plain should be avoided. Wherever possible, construction activities and development in flood plains should be avoided. In many instances, flood plains can be integrated into the project design to create a level of aesthetic value and /or used as a natural or recreational area.

The Indiana Department of Natural Resources' Division of Water regulates activities conducted within the floodway of Indiana creeks, streams, rivers, and other conveyance systems. Site designers should ensure that activities associated with the project do not impact flood plains and that appropriate permits are obtained for flood plain areas that will be impacted by project operations before the actual activity commences.

PRESERVATION & PROTECTION—NATURAL SITE DESIGN

Steep Slopes



Steep slopes consist of areas where the slope gradient is typically 15 percent or greater. These areas can occur on hillsides, ridges, or along the sides of ravines.

Planning Consideration

- Avoid development on steep hill, ridge, and ravine slopes, especially those with side slopes of 15 percent or greater.
- Preserve existing vegetation to minimize erosion potential and generation of sediment. (Preservation of existing vegetation eliminates the difficulty of trying to re-establish vegetation in these areas.)
- Build on flatter areas to reduce soil cut-and-fill volumes and the cost of grading operations.

Discussion

Developing on steep slopes causes increased soil erosion and storm water runoff during and after construction. U.S. Department of Agriculture Natural Resources Conservation Service studies have shown that soil erosion is greatly increased on slopes that have a grade of 15 percent or more. Developing on steep slopes also results in excessive sediment loading of storm water runoff. Therefore, developing on slopes with a grade of 15 percent or greater should be avoided whenever feasible in order to minimize erosion, soil loss, degradation of surface water, and excessive storm water runoff. Furthermore, slopes with a grade of 25 percent or more should be avoided altogether.



STEEP SLOPES

More land is disturbed when developing steep slopes versus development of flat ground. Ideally, steep slopes should be left in their natural, undisturbed state to preserve the natural topography and character of the site, the natural soil and associated soil characteristics, and existing vegetation. Leaving areas undisturbed will minimize erosion potential, protect water quality, and minimize grading costs.

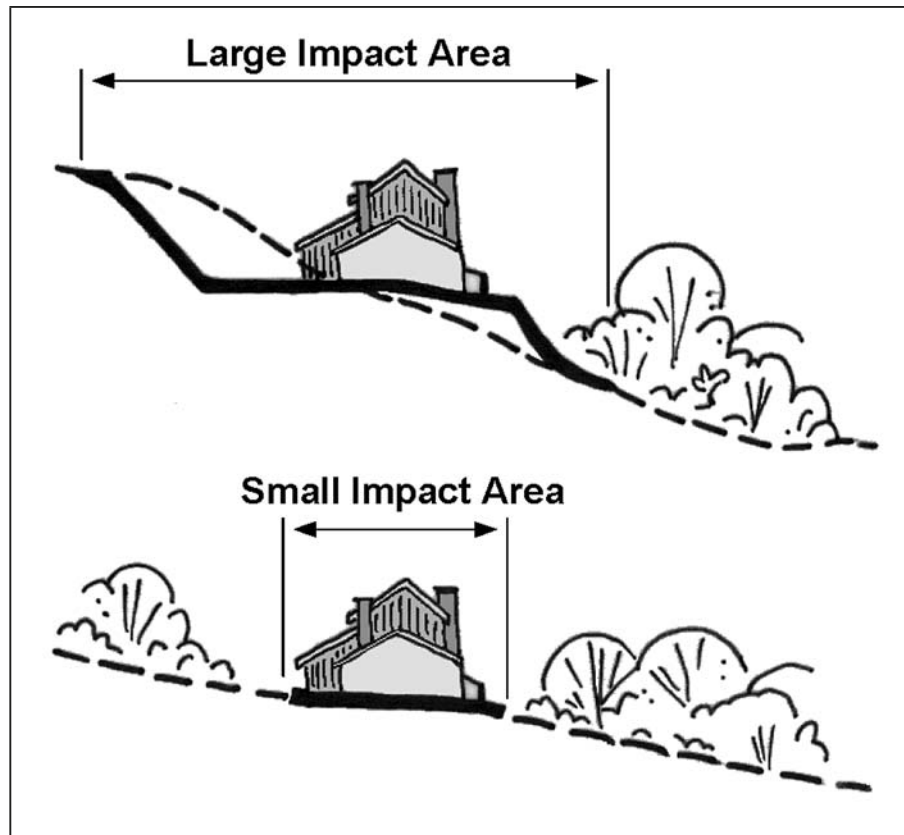

Source: Georgia Stormwater Management Manual, 2001

PRESERVATION & PROTECTION—NATURAL SITE DESIGN

Karst



Source: Richard Fields, Indiana Department of Natural Resources

Karst is a landscape feature characterized by sinkholes, ravines, crevices, and underground streams and caves formed in soluble calcium carbonate or dolomite (calcium magnesium carbonate) limestone bedrock. These features are formed when the bedrock is dissolved by water.

Planning Consideration

- Measures should be used to reduce concentration of runoff.
- Storm water conveyance structures should be used to allow increased infiltration and reduce pollutants generated.
- Investigate areas underlain by carbonate rock to identify sink holes.
- Where feasible, direct storm water runoff 1000 feet or more away from the edge of existing sinkholes and if possible, discharge it to an area that is not underlain by limestone bedrock.

Discussion

From a storm water management perspective it is very important to identify karst sinkholes, fractures, and cavities due to their potential to pose environmental threats and/or construction hazards.

In karst areas, surface water flows very quickly into caves and sinkholes resulting in very little time for storm water to infiltrate into the soil. Storm water runoff often picks up contaminants such as human and animal waste, pesticides, fertilizers, petroleum products, and other pollutants as it flows across the earth's surface. When this contaminated runoff enters karst features it can travel great distances underground and may result in the contamination of wells, springs, and aquifers. Spills of pollutants such as chemicals and hazardous materials are of special concern in these areas. In addition, impacts on aquatic cave-dwelling species can result in adverse effects of biologic communities. For example,

KARST

endangered species such as the blind cave fish are especially prone to the adverse effects of contaminated storm water runoff.

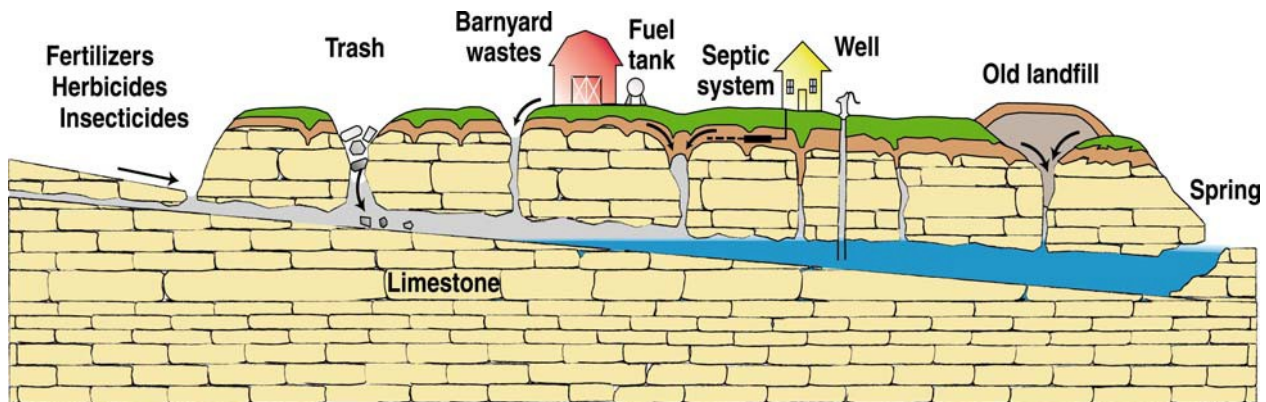

Diagram concept by Indiana Geological Survey, R.L. Powell; drafted by R.S. Taylor

Percolation of surface water into the soil and underlying limestone bedrock of karst areas often results in sinkholes and underground caves. Construction activities often accelerate sinkhole formation due to the disturbance of existing soil and bedrock conditions and the alteration of existing hydrology and drainage patterns. To help reduce the impact, emphasis should be placed on reducing runoff through aggressive mulching and seeding measures. In addition, the increase in impervious surface cover and increased structural loads on the soil frequently result in ground failure. For these reasons detention/retention ponds should be designed and constructed with a liner and discharges from storm water management facilities and impervious surfaces should be routed to stable areas. The use of buffers are encouraged adjacent to karst features, especially in areas where

large amounts of impervious surface must be added. One way to accomplish this is to maintain large vegetative strips on slopes to help filter and slow runoff. In addition, alternative measures can be substituted for impervious surfaces to allow more absorption of flow and less runoff. These measures include but are not limited to porous pavers, pervious concrete, and porous asphalt. The use of infiltration measures should be carefully evaluated before their use. Where feasible, storm water flows should be directed away from limestone bedrock.

For the protection of ground water quality, storm water conveyance measures that are to be used in karst areas should be designed to spread or disperse storm water runoff over the largest area practicable. Dispersion of storm water runoff helps eliminate concentrated flows and the pooling or ponding of runoff. Grass waterways are another effective storm water management measure that can be used in karst areas.

KARST

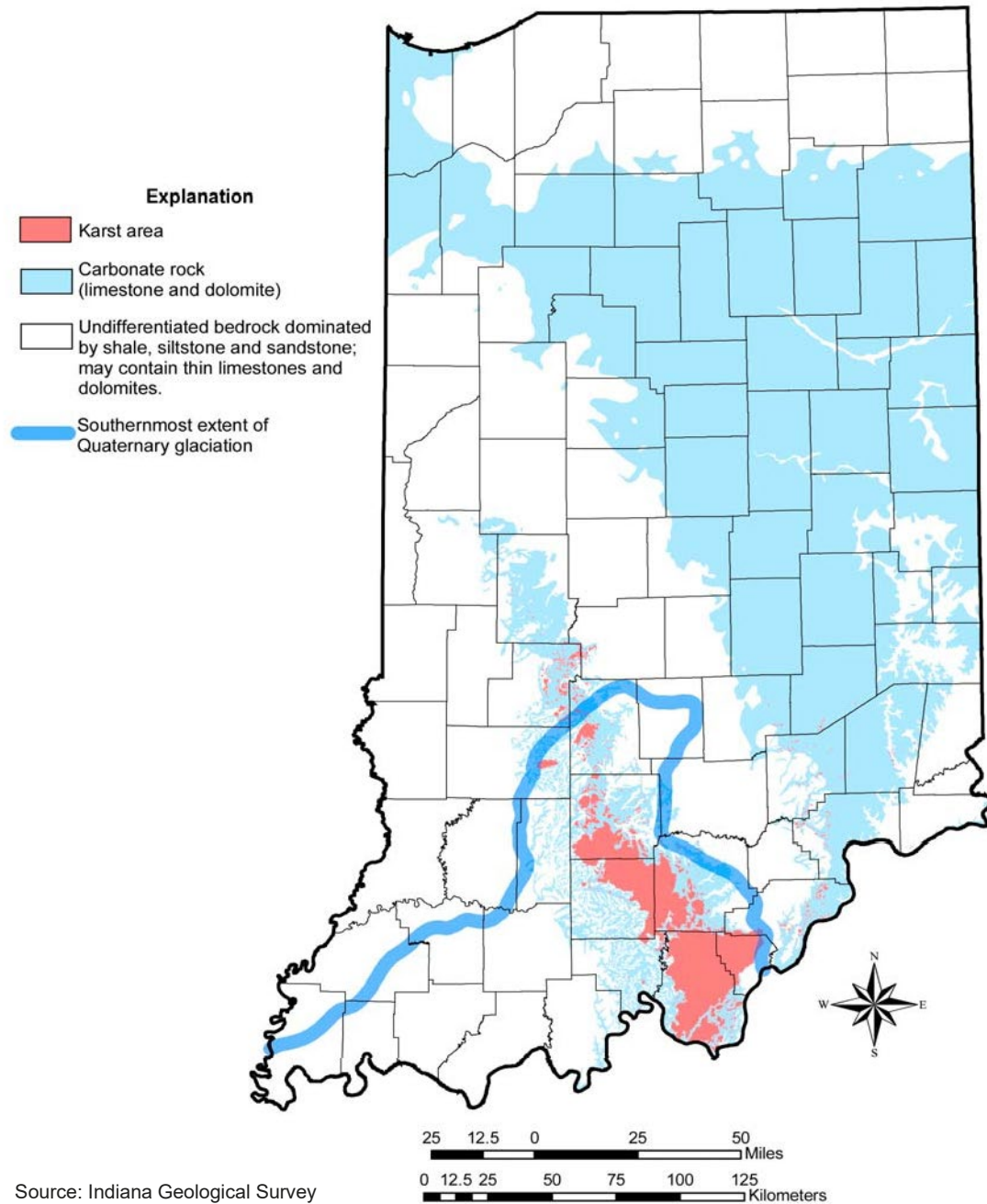

Additional Resources

Internet:
Indiana Geological Survey
<http://igs.indiana.edu/index.cfm>

This page was intentionally left blank.

LAND/SITE UTILIZATION

After gaining an understanding of the natural resources occurring on the project site it is time to begin to understand how the project can be designed with each of these features in mind.

This section provides an in-depth discussion of several project management activities that should be considered early in the design process. These activities include fitting the design and layout of the project to the natural landscape, restricting land disturbance in unique resource areas, planning land disturbance in an orderly fashion to reduce the amount of bare earth exposed at a given time, and utilizing existing buffers, riparian corridors, and vegetated areas as either amenities or part of the storm water management system. There is also a discussion of the importance of soil properties and how soils are directly related to site planning, design, and the selection of storm water measures.

Incorporating these land use decisions into the design and layout of the project site can minimize the overall impact of the project. Benefits include but are not limited to site aesthetics, reduction of impervious surfaces, decreased generation of pollutants, and treatment of storm water runoff.

This page was intentionally left blank.

LAND/SITE UTILIZATION

Soil Properties



Source: Natural Resources Conservation Service

Soil properties, limitations, and hazards play a very important part in the planning, design, and layout of a project. This planning principle affects nearly every aspect of a project.

Planning Consideration

- Leave highly erodible or unstable soils in their natural condition to prevent erosion, sedimentation, and water quality degradation problems.
- Leave highly erodible or porous soils as undisturbed conservation areas.
- Use permeable soils as nonstructural storm water infiltration zones.

Discussion

Soils generally have the greatest impact on project planning, design, and layout. Their inherent properties, limitations, and hazards can literally dictate the layout of building lots/pads, roads and streets, storm sewers, on-site sewage disposal facilities (where applicable), and other project infrastructure. Soils also play a significant role in the selection and installation of construction and post-construction storm water management measures.

Planning, Design, and Layout

Soil characteristics such as depth to bedrock, depth to the seasonal water table, permeability, shrink-swell potential, texture, erodibility, etc. need to be evaluated and factored into the design and layout of a project. Soils data must also be taken into account when evaluating, selecting, locating, and designing construction and post-construction storm water management measures for the management and treatment of storm water runoff.

General soils maps, found in Natural Resources Conservation Service county soil surveys, are often an excellent place to start when incorporating soils information into the site plan and storm water management plan. General soils maps

SOIL PROPERTIES

provide groupings of soils with similar properties. Depending on the size of the project, general soils maps can be used to guide the placement of buildings and impervious surfaces and select the most suitable areas of the project site for common areas, greenways, buffer zones, and natural preservation.

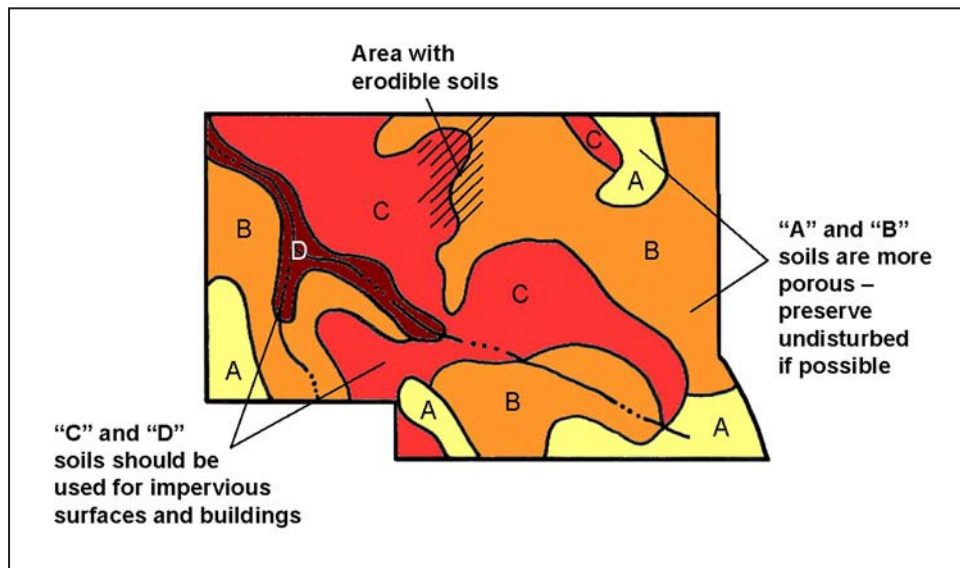

Source: Georgia Stormwater Management Manual, 2001

Local soil resource maps and interpretive tables, also found in Natural Resources Conservation Service county soil surveys, can be useful in the planning, design, and layout of a project site. The soil resource maps can be used to identify and delineate specific soil types on the site plan and the tables can be used to group soils with similar characteristics, properties, limitations, and hazards. For example, these maps and tables can be used to identify highly erodible soils and unstable soils that should be maintained in their natural state to minimize erosion potential and sediment impacts and avoid potential structural damage to buildings.

Construction

Soils can have a significant impact on the location and stability of buildings and roads and streets. Soils with a seasonal high water table can affect the stability of roads and streets and result in frost action problems in colder climates. A high water table can result in flooded crawl spaces or basements of buildings.

Development of the site plan must take soil properties, limitations, and hazards into account when determining the location of buildings and roads and streets. Areas of highly erodible or unstable soils should be avoided to the greatest extent practicable to avoid erosion, sedimentation and potential structural problems. If structures must be located on highly erodible soils, the storm water pollution prevention plan should identify storm water measures that can be used to minimize erosion on these areas.

SOIL PROPERTIES

Permeable soils suitable for infiltration of storm water runoff should be left in their natural state and to the greatest extent practicable, preserved for use as natural space such as common areas and greenways. On projects requiring the construction of buildings and roads/streets, locate the structures on soils with more restrictive permeabilities or very rapid permeabilities and reserve the permeable soils for storm water infiltration and treatment.

Post-Construction

Soils play a major role in the selection and implementation of post-construction storm water quality measures. Soil properties can literally dictate whether or not to use filtration and/or infiltration measures. For example, the use of filtration and infiltration practices may be severely restricted or impractical in soils with a seasonal high water table unless there is some way to artificially lower the water table. Infiltration measures will be ineffective in soils that have a high clay content or soils that have an extremely high gravel content.

Porous sandy and gravelly soils allow storm water runoff to infiltrate and recharge ground water supplies. Dispersion of storm water runoff over these highly permeable soils helps reduce the amount of runoff and reduces peak discharges. Areas of permeable soils should be considered as a storm water management option, provided that the soils are not easily erodible or unstable.

Permeable soils, such as sands and sandy loams (hydrologic soil group A and B), provide infiltration into the subsoil at a rate that allows for the removal of some storm water pollutants. Conversely, very rapidly permeable soils like coarse sands and gravel provide little opportunity for the removal of storm water pollutants.

This page was intentionally left blank.

LAND/SITE UTILIZATION

Reduce Limits of Clearing & Grading



Reducing the limits of clearing and grading is a planning principle that can be used to preserve existing vegetation, natural drainage patterns, and the aesthetics of a project site. In addition, this principle helps minimize the clearing and grading costs associated with a construction project.

Planning Consideration

- Natural conservation areas and other site features can be protected using these techniques.
- More undisturbed natural area on a site is preserved.
- Set up limits of disturbance for development activities.
- Limit the site footprint to reduce the clearing and disturbance of a site.

Discussion

Minimizing clearing and grading on a construction site helps to preserve existing vegetation and natural drainage patterns of the site. Preservation of these features often enhances the project's aesthetics and helps minimize the costs associated with clearing and grading of the project. Clearing and grading of areas highly susceptible to erosion generally requires the installation of more sophisticated and costly storm water quality measures to control erosion and sedimentation on the construction site.

To the greatest extent practicable, clearing and grading activities should be confined to the least critical areas on the project site. Long, steep slopes, areas of highly erodible soils, unique natural areas, etc. should be used as open space or natural areas on the project site. Where possible, minimize the number and width of site access roads and locate them in areas that will be used later for streets, utility corridors, and rights-of-way. Locate areas designated for staging of construction equipment, employee parking areas, construction offices/trailers,

REDUCE LIMITS OF CLEARING & GRADING

and construction material and soil stockpile areas in zones designated for future clearing and grading.

There are several methods that can be used to reduce the limits of clearing and grading. These methods are typically referred to as minimal disturbance methods. The most common minimum disturbance methods used include limiting the footprint of land disturbance and development, fitting the site design to existing terrain, and using special procedures and equipment.

The limit of disturbance should reflect reasonable construction techniques and equipment needs together with the physical characteristics of the development site such as soils or slope. Limit of disturbance distances may vary depending on the type of development, the size of the project site, and the specific development features involved.

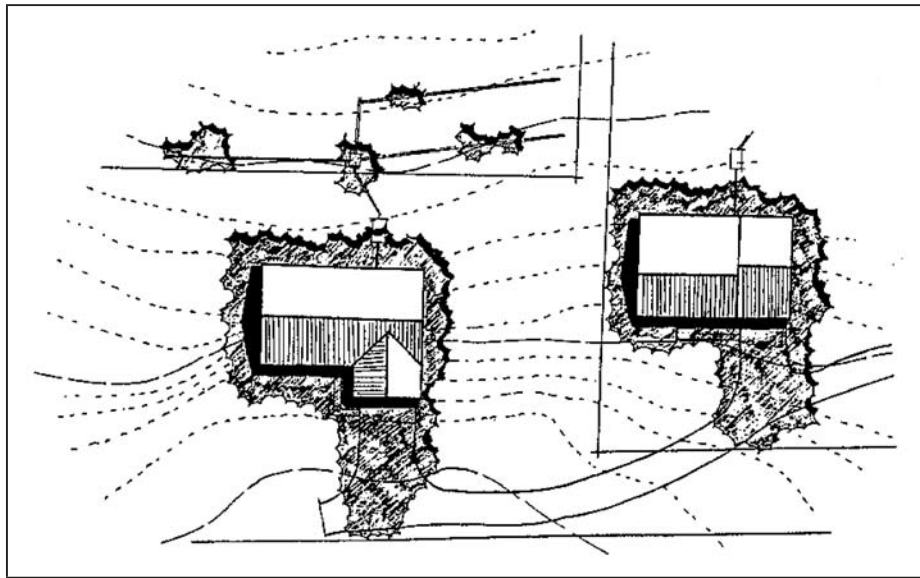

Source: Delaware Department of Natural Resources and Environmental Control and the Brandywine Conservancy, 1997

Limiting the footprint of construction is another method that can be used to reduce the limits of clearing and grading. This method maps all of the limit of disturbances to find the smallest possible area to be cleared or disturbed. The photograph on the next page illustrates the use of this method to minimize disturbance of existing vegetation.

REDUCE LIMITS OF CLEARING & GRADING



Source: Georgia Stormwater Management Manual, 2001

The third method used to reduce the limits of clearing and grading is fitting the project site design to the existing terrain. This method and the use of special procedures and equipment is discussed further in other sections of this manual.

This page was intentionally left blank.

LAND/SITE UTILIZATION

Fit the Design to the Existing Terrain



Fitting the design to the existing terrain allows for the planning, design, and placement of buildings, roads/streets, utilities, and other infrastructure in a manner that compliments the existing topography and minimizes the amount of clearing and grading of the project site.

Source: Georgia Stormwater Management Manual, 2001

Key Benefits

- Aids in preserving the natural hydrology and drainageways of a site.
- Decreases the need for grading and land disturbance.
- Minimizes erosion potential, environmental impacts, and project costs.

Planning Consideration

- Plan and lay out roads and streets to follow natural landforms.
- Position buildings and other impervious surfaces away from steep slopes, drainageways, and flood plains.

Discussion

When developing a project, the site design should be tailored to fit existing site conditions and avoid unnecessary land disturbance. Buildings, roads/streets, utilities, infrastructure, and other features associated with the project should be tailored to fit the existing terrain. Taking this approach lessens the impact to the existing soil and vegetation and preserves the hydrology and natural drainage patterns of the site. Fitting the design of the project to the terrain also reduces the amount of clearing and grading which in turn minimizes erosion, environmental impacts, and project costs.

Buildings and impervious surface areas should be kept away from steep slopes, natural drainageways, and flood plains. They should be located in areas of existing, flat terrain to allow existing drainage systems to remain in place. The major axis of buildings should be kept parallel to the contour of the land.

FIT THE DESIGN TO THE EXISTING TERRAIN

Roads and streets should follow the natural landforms and should be designed around natural drainageways and stream buffer zones. For example, in rolling, dissected terrain, collector roads and streets should follow ridgelines and natural valleys/ravines. This greatly reduces the amount of clearing and grading required. Roads and streets branching off of these main collector streets should form short loops or end in cul-de-sacs. This pattern resembles the branched pattern of ridgelines and drainageways in the natural landscape. This pattern also minimizes the removal of vegetation on existing, steep grades and reduces the number of natural stream and drainageway crossings. In places where the terrain is flat, it is easier to lay the roads and streets out in a grid like pattern because drainage patterns will be less complicated.

Development on Steep Terrain



Source: Georgia Stormwater Management Manual, 2001

Development on Flat Terrain



Source: Georgia Stormwater Management Manual, 2001

LAND/SITE UTILIZATION

Utilize Undisturbed Areas & Natural Buffers

Preserving undisturbed areas and using natural buffers is a planning and site design principle that can be effectively used to minimize clearing and grading, filter and infiltrate storm water runoff, reduce environmental impacts, and minimize the cost of development. The theory behind using undisturbed areas and natural buffer zones is to intercept storm water runoff before it becomes concentrated and disperse it evenly over the natural area or buffer zone.

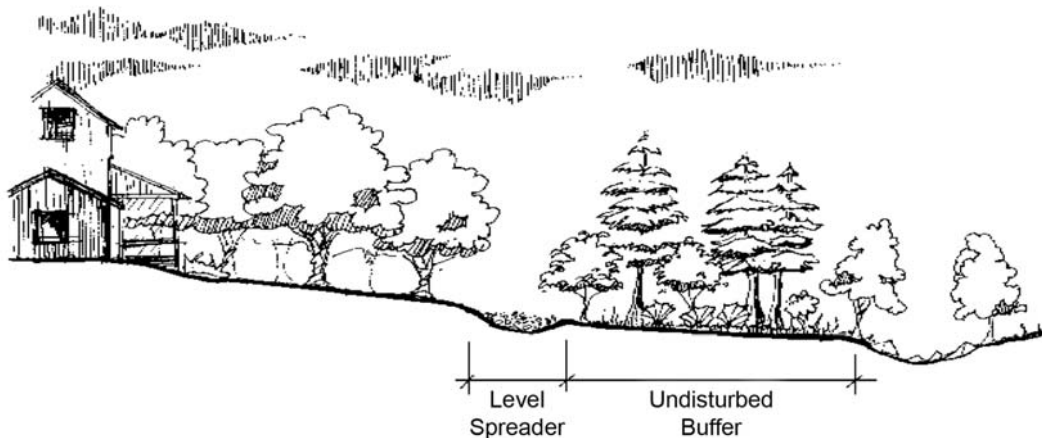

Source: Adapted from North Carolina Department of Environment and Natural Resources, 1998

Key Benefits

- Makes use of vegetated areas to filter and infiltrate storm water runoff.
- Directing runoff towards pervious vegetated areas increases overland flow time and reduces peak flows.
- Natural depressions provide for inexpensive storage and detention of storm water runoff.

Planning Consideration

- Minimize the amount of impervious surface area and use storm water management measures to convert concentrated flows from the impervious areas into sheet flow that is discharged into pervious, vegetated areas.
- Use storm water management measures to convert concentrated flows into sheet flows and direct the runoff towards vegetated buffer zones and undisturbed areas.
- Use natural depressions for storage of storm water runoff.

UTILIZE UNDISTURBED AREAS & NATURAL BUFFERS

Discussion

Directing storm water runoff from impervious surface areas to undisturbed natural areas, vegetated areas, riparian buffer zones, and other undisturbed natural areas slows storm water runoff and allows the runoff to infiltrate into the soil. These vegetated areas and buffer zones also facilitate the removal of storm water pollutants via infiltration, absorption, ion exchange, precipitation, and biodegradation thereby preventing pollutants from reaching rivers, lakes, and other waterbodies.

Natural depressions can be used to store storm water runoff temporarily and allow it to infiltrate into the underlying soil (especially in areas of porous soils). In this way, the runoff is “disconnected” from hydraulically efficient structural conveyances such as a curb and gutter or storm drain systems.

Methods for disconnecting impervious areas include using roof designs that drain to vegetated areas, directing storm water runoff from impervious surfaces to vegetated areas, diverging the direction of storm water flow from impervious surfaces (e.g., parking lots), and shaping landscaped areas to shed storm water sheet flows to pervious areas.

Paved Surfaces Designed to Disperse Flow to Vegetated Areas

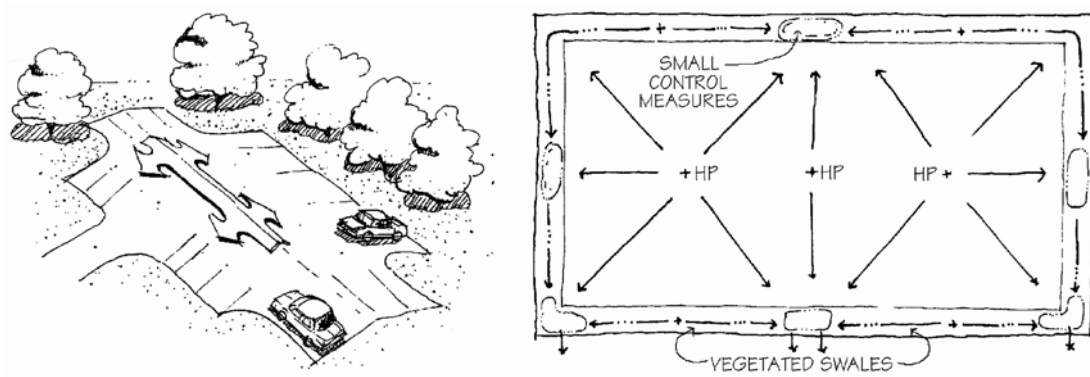

Source: North Carolina Department of Environment and Natural Resources, 1998

PLANNING PRINCIPLES

Once the designer is knowledgeable of the project site and begins to plan the layout, design, and infrastructure there are still many decisions to be made. There are numerous storm water quality measures that can be selected to manage storm water quantity, treat storm water runoff, and reduce the discharge of pollutants that will be associated with the final land use. Before the final selection of storm water quality measures, there are other planning and design opportunities that should be taken into account by the designer.

This section provides an in-depth discussion of several planning or design principles that should be considered early in the project. The principles described in this section are a variation of typical project design. The principles include but are not limited to creative development design, roadway design, building and parking lot footprints, setbacks and frontages, and storm water conveyance system alternatives. Communities across Indiana have strict guidelines or ordinances that apply to the design of subdivisions, commercial projects, and other development. Most of the principles described in this section have not necessarily been adopted or incorporated into local ordinances and may require a special approval or a variance from local plan authorities.

Incorporating these planning principles into the design and layout of the project site can minimize the overall impact of the project. Benefits include but are not limited to site aesthetics, reduction of impervious surfaces, decreased generation of pollutants, and treatment of storm water runoff.

This page was intentionally left blank.

PLANNING PRINCIPLES

Creative Development Design

Creative development design is a planning principle that can be used to reduce the amount of impervious cover on a project site. The theory behind this principle is to reduce storm water runoff volumes and velocities by reducing the percentage of pervious cover, allowing for increased infiltration of storm water into the soil.

Examples of Reducing Impervious Cover



Cul-de-Sac with Landscaped Island



Narrower Residential Street



Landscape Median in Roadway



"Green" Parking Lot with Landscaped Islands

Source: Georgia Stormwater Management Manual, 2001

Key Benefits

- Reduces storm water runoff volumes and velocities.
- Reduces amount of pollutants generated.
- Minimizes environmental impacts.
- Minimizes disturbance to wildlife habitat.
- Preserves aesthetics of project site which can increase salability of lots.

CREATIVE DEVELOPMENT DESIGN

Planning Consideration

- Minimize roadway lengths and widths.
- Minimize building footprints.
- Minimize parking footprints.
- Reduce setbacks and frontages.
- Reduce the radius of cul-de-sacs.
- Use fewer or alternative cul-de-sacs.

Discussion

A primary focus of urban and suburban storm water management planning is to minimize the frequency and severity of flooding. This is generally done by reducing peak discharges from new development. Reducing peak discharges requires generating a site design that minimizes the use of pavement and impervious surfaces, incorporates infiltration measures to restore predevelopment runoff volumes, and uses vegetated drainage swales designed to match predevelopment storm water runoff velocities.

One of the most essential parts of better site design is related to the amount of impervious cover. Impervious cover includes sidewalks, roads, rooftops, parking lots, and basically any surface that does not allow water to infiltrate into the soil. The more impervious cover in an area, the greater the amount of storm water generated. Large amounts of storm water increase pollutant loadings. Conversely, a site designer can reduce the amount of storm water that is generated by reducing the amount of impervious cover.

“Cluster development” is one design concept that can be used to reduce impervious surface cover. This design concept minimizes the amount of land disturbance, concentrates utility lines and connections in one area or corridor, and provides more open, natural space. “Cluster development” also reduces environmental impacts by decreasing the amount of soil exposed to erosive forces and decreasing the amount of impervious surface area which results in less storm water runoff. Another advantage of “cluster development” is that it generally reduces overall development costs by reducing the amount and size of clearing and grading operations, paving materials needed for roads and streets, and infrastructure for storm water conveyance/control and treatment.

The principle behind “cluster development” is to concentrate development within one section of a site. Parking areas, driveways, and common or open areas are shared. Lot sizes are reduced in size and typically are more irregular in shape. Clustering buildings in a centralized area minimizes land disturbance and requires less land area for the installation of utilities and construction of roads and streets.

CREATIVE DEVELOPMENT DESIGN

Planning and designing “cluster developments” should begin by developing a prototype cluster(s) on paper for the desired unit type and site situation before addressing lot layout on the total project site. This avoids many of the pitfalls encountered in laying out roads first and then building lots. By working out the objective and problems of lot-street relationships in advance, you can more readily see opportunities to capitalize on the project site’s physical characteristics. For example, the site planner will have greater opportunities to minimize the project’s environmental impacts and maximize the aesthetics and amenities of the site.

This page was intentionally left blank.

PLANNING PRINCIPLES

Roadway Design



Roadway design is a planning principle that can be used to reduce impervious surface cover by reducing the lengths and widths of roadways and cul-de-sacs.

Key Benefits

- Minimizes storm water runoff and associated pollutants generated by reducing the amount of impervious surface cover.
- Reduces the cost of roadway construction and maintenance.

Planning Consideration

- Reduce overall street length by considering different site and road layouts.
- Reduce street width by using narrow street designs.
- Consider alternative cul-de-sac designs.

Discussion

In many communities, streets are designed and installed at a greater width than necessary. Implementing alternative street layouts can often reduce the total length of streets and significantly minimize the impervious surface cover of a development site. Therefore, site designers should evaluate different street and cul-de-sac layouts that will result in reduced lengths and widths. Site designers should also look for associated landscaping measures that will provide additional infiltration of storm water runoff discharging from impervious surface areas.

ROADWAY DESIGN

Streets and Cul-de-Sac Widths

Typically, streets are designed to accommodate two rows of traffic and a row of parked cars on either side of the street. To reduce the amount of impervious surface cover, residential and private streets within a development should be designed for the minimum required pavement width that is needed for travel lanes, on-street parking, and emergency vehicle access. Some alternatives for accomplishing these objectives might include:

- Reducing on-street parking to one lane.
- Implementing single lane, one-way loop roads.
- Eliminating parking on cul-de-sacs with less than 200 average daily trips and two-way loop streets with less than 400 average daily trips.
- Using parking bays to accommodate the parking requirements of local residents.

Using the above approaches allows for a substantial reduction in the amount of impervious surface cover.

Turnarounds

Many cul-de-sacs and turnarounds have a radius of more than 40 feet. From a storm water management perspective, this creates a huge amount of impervious surface cover, increasing the quantity of storm water runoff. Therefore, to minimize the amount of impervious surface cover generated at a site, the size of cul-de-sacs and turnarounds should be reduced via alternative designs or eliminated altogether.

Providing enough turnaround area for different types of vehicles that may need to use cul-de-sacs and turnarounds is a significant aspect to consider in the planning and design process. For example, many vehicles like fire trucks, service vehicles, and school buses generally require a larger turning radius than passenger vehicles. In recent years some fire trucks have been designed with a smaller turning radius and some service vehicles are now equipped with triaxles which require a smaller turning radius. In regard to school buses, it is becoming commonplace for school children to board the bus at the intersection of the cul-de-sac and collector street rather than the bus entering the individual cul-de-sacs.

Many alternative cul-de-sac and turnaround designs generate less impervious surface cover than the traditional 40-foot cul-de-sacs. When planning and designing cul-de-sacs and turnarounds, use alternative designs to provide the minimum radii required to accommodate emergency and maintenance vehicles. Some of these alternatives include:

ROADWAY DESIGN

- Reducing the radius of cul-de-sacs to 30 feet.
- Creating hammerhead turnarounds.
- Using loop roads.
- Using pervious islands in the center of the cul-de-sac.

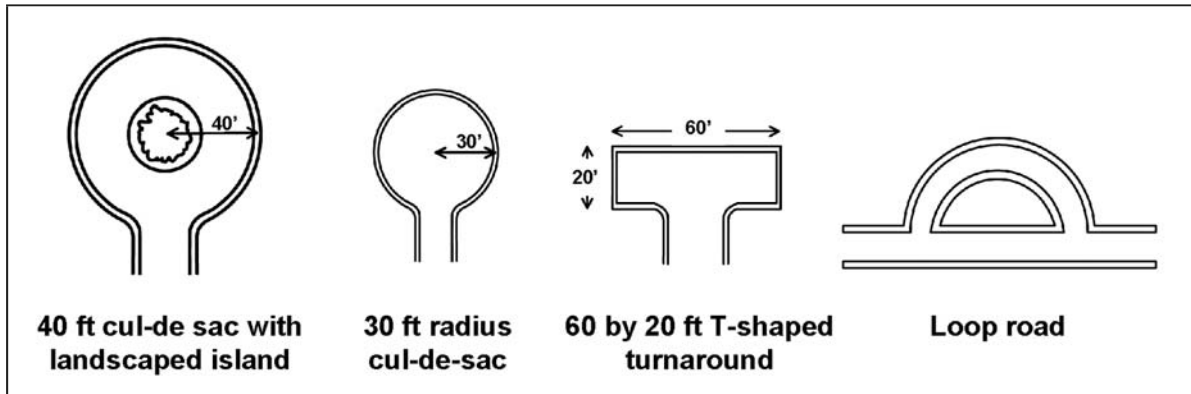

Source: Schueler, 1995

Some communities have specific planning and design criteria for streets, cul-de-sacs, and turnarounds. Therefore, altering street and cul-de-sac designs may require obtaining variances from the local plan department. In the future, local plan departments may be considering updates or modification of their local ordinances to allow for alternative designs.

Changing street and cul-de-sac designs may also require public information and outreach marketing strategies to educate the local residents about the environmental benefits of such design changes.

This page was intentionally left blank.

PLANNING PRINCIPLES

Building Footprints



The principle behind “building footprints” is to reduce the impervious footprint of commercial buildings and residences by constructing taller buildings while maintaining the same building floor-to-soil surface area ratio.

Key Benefits

- Maximizes the amount of pervious surface area for storm water infiltration.
- Minimizes the amount of storm water runoff.
- Minimizes the amount of pollutants delivered to receiving waterbodies.

Planning Consideration

- Use building designs that are taller in order to reduce the impervious footprint of buildings.

Discussion

The building unit-to-lot relationship is a facet of site planning too often accepted as a “given,” even though it offers a good opportunity to reduce runoff volumes, runoff velocities, and peak discharges. Planning and designing a development project should take into consideration the unit-to-lot relationship and attempt to match it to the existing site and hydrologic conditions.

Using alternative building designs and constructing taller buildings helps minimize the amount of impervious surface cover by reducing the building footprint and rooftop area.

Combining or consolidating the functions of a building or segmenting facilities can also be effective methods for reducing individual building footprints.

BUILDING FOOTPRINTS

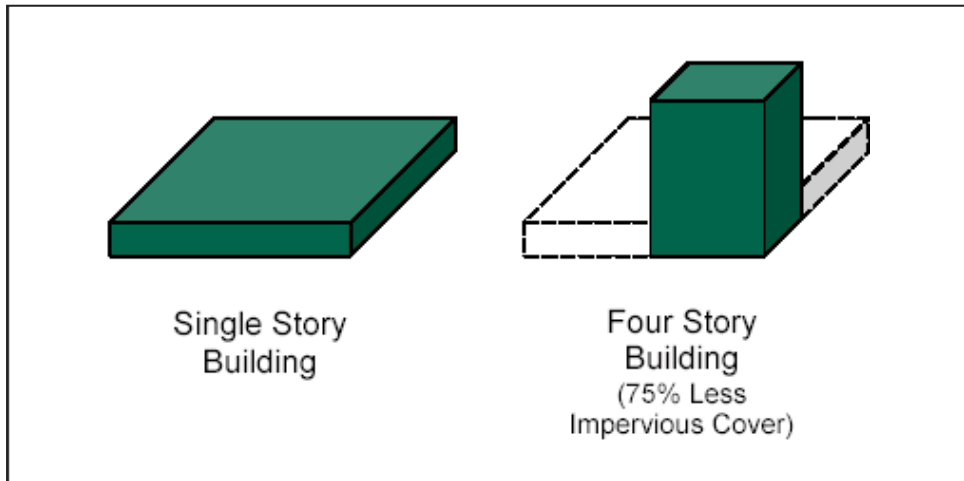

Source: Georgia Stormwater Management Manual, 2001

PLANNING PRINCIPLES

Parking Lot Footprints



The principle behind “parking lot footprints” is to reduce the amount of impervious surface cover associated with parking lots.

Key Benefits

- Reduces the amount of impervious surface cover.
- Reduces storm water runoff and amount of pollutants delivered to receiving waterbodies.

Planning Consideration

- Minimize the number of parking spaces.
- Reduce stall dimensions.
- Consider parking structures and shared parking.
- Consider using porous surfaces in vehicle overflow areas.

Discussion

Parking lots are often larger than necessary. This is due to the practice of designing for peak occupancy. As the following table shows, the number of parking spaces provided can often be reduced significantly if average parking demand numbers were used in the planning and design process.

PARKING LOT FOOTPRINTS

Conventional Minimum Parking Ratios

Land Use	Parking Requirement		
	Parking Ratio	Typical Range	Actual Average Parking Demand
Single family homes	2 spaces per dwelling unit	1.5–2.5	1.11 spaces per dwelling unit
Shopping center	5 spaces per 1000 ft ² GFA*	4.0–6.5	3.97 per 1000 ft ² GFA*
Convenience store	3.3 spaces per 1000 ft ² GFA*	2.0–10.0	-----
Industrial	1 space per 1000 ft ² GFA*	0.5–2.0	1.48 per 1000 ft ² GFA*
Medical/dental office	5.7 spaces per 1000 ft ² GFA*	4.5–10.0	4.11 per 1000 ft ² GFA*

*GFA = Gross floor area of a building without storage or utility spaces.

Source: U.S. EPA, 2005, Using Smart Growth Techniques (Adapted from Institute of Transportation Engineers, 1987; Smith, 1984; Wells, 1994)

There are several methods that can be used to minimize impervious surface cover associated with parking lot footprints. Some of these methods are:

- Setting maximum sizes for parking spaces.
- Minimizing parking stall dimensions.
- Providing spaces for compact cars.
- Incorporating efficient parking lanes.
- Constructing multi-level parking structures.
- Sharing parking lots.
- Installing alternative porous surfaces in overflow parking areas.



PARKING LOT FOOTPRINTS

One of the easiest and least costly methods of reducing parking lot footprints is adjusting the size of individual parking stalls. Reducing the length and width of parking stalls can greatly reduce the size of parking lots. Designing parking lots with areas and parking stalls designated for specific types of vehicles, such as compact cars or sport utility vehicles, can provide for an efficient use of space.

Parking structures can also have a huge impact on the reduction of the overall parking lot footprint.

Shared parking is a method that works well in mixed use areas. For example, an office complex where employees work daytime hours throughout the week may share a lot with a church which typically meets on weekends and evenings.

Installing porous or permeable surfaces in parking lot overflow areas is an effective method for minimizing the amount of storm water runoff generated from these areas. These systems can be used in both new development and redevelopment/retrofit projects.



Source: Georgia Stormwater Management Manual, 2001

Porous paver or porous pavement systems are well suited for use in parking lot overflow areas. Porous pavers consist of structural units which have voids filled with a pervious material such as sand or gravel. Porous paver systems can be vegetated so that the paver system is inconspicuous or they can be left visible to the public. Porous pavement systems include porous asphalt and pervious concrete. These systems have an advantage over conventional asphalt and concrete because they allow storm water runoff to be stored and treated.

Proper installation and maintenance of porous paver and pavement systems is essential if they are to perform properly. These systems do require more maintenance than conventional asphalt and concrete parking areas.

This page was intentionally left blank.

PLANNING PRINCIPLES

Setbacks & Frontages



The principle behind “setbacks and frontages” is to reduce the total length of impervious streets and driveways.

Key Benefits

- Reduces the amount of impervious surface cover.
- Reduces the amount of storm water runoff and the amount of pollutants delivered to receiving waterbodies.

Planning Consideration

- Reduce front and side setback distances for homes and buildings.
- Use narrower frontages.

Discussion

The reduction of setback and frontage distances will reduce the amount of impervious surface cover associated with a development site. For example, on residential and commercial developments, shortened setback distances reduce the amount of impervious cover from driveways and entryways. A setback of 20 feet is generally sufficient for parking a vehicle in a driveway without infringing on the public right-of-way. Reducing a setback distance from 30 feet to 20 feet can reduce driveway and sidewalk impervious surface cover by 30 percent or more.

SETBACKS & FRONTAGES

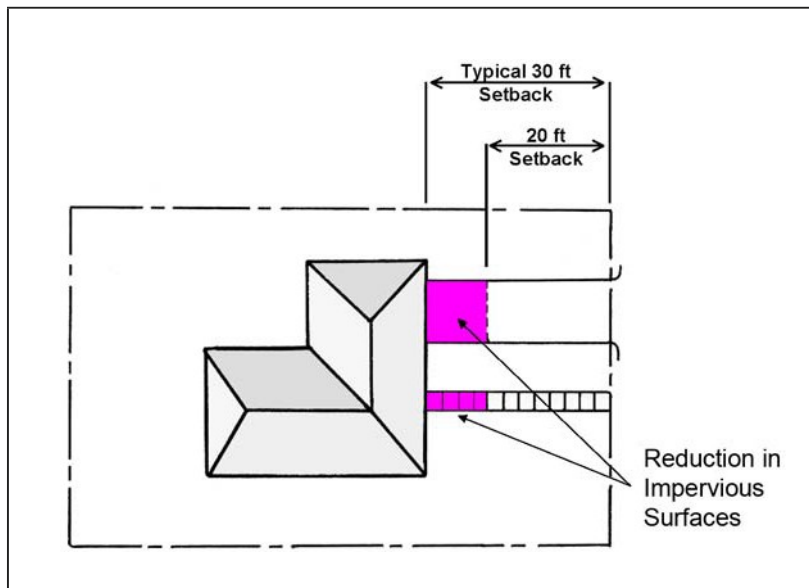

Source: Adapted from Minnesota Pollution Control Agency, *Protecting Water Quality in Urban Areas*, 1989; and Georgia Stormwater Management Manual, 2001

As shown in the photograph of this measure, minimizing side yard setbacks and using narrower frontages can significantly reduce impervious surface cover and total street lengths. This is especially important in cluster developments and open space designs.

PLANNING PRINCIPLES

Natural Drainageways vs. Storm Sewers



*This principle takes advantage of **natural drainageways** by incorporating them into a project's storm water management system.*

Key Benefits

- Lowers the expense of road and storm sewer construction as well as the need for land disturbance and grading.
- Maintains natural storm water runoff storage, infiltration, and treatment.
- Storm water filtration and infiltration occurs when it is used with buffer systems.
- Provides for longer travel times and lower peak discharges of storm water runoff than hydraulically efficient man-made channels.

Planning Consideration

- Preserve natural flow corridors.
- Direct runoff to natural drainageways, ensuring that peak flows and velocities will not cause channel erosion.
- Use vegetated channels (enhanced wet or dry swales or grass channels) in place of curb and gutter to convey and treat storm water runoff.

Discussion

Natural drainage features such as creeks and streams that flow through or are adjacent to a project site are an amenity that can add aesthetic value to the property and therefore should be incorporated into the project design and layout. Incorporating natural drainageways into the project's drainage system also helps

NATURAL DRAINAGEWAYS VS. STORM SEWERS

minimize the cost of the project by reducing grading costs, the investment in man-made drainage structures, and installation of the drainage system.

Storm sewers and other structural drainage systems are generally used in urban development projects to convey storm water runoff in the most efficient manner. Using these man-made systems increases storm water runoff, runoff flow velocities, and delivery of pollutants to the receiving water body. The alternative to this approach is to use constructed drainageways and vegetated swales to carry the storm water. In low-density developments and subdivisions, drainageways are well suited for removing storm water runoff pollutants, allowing filtering and infiltration of runoff, lowering peak flow discharges, providing higher storage capacities, and reducing the velocity of storm water runoff.

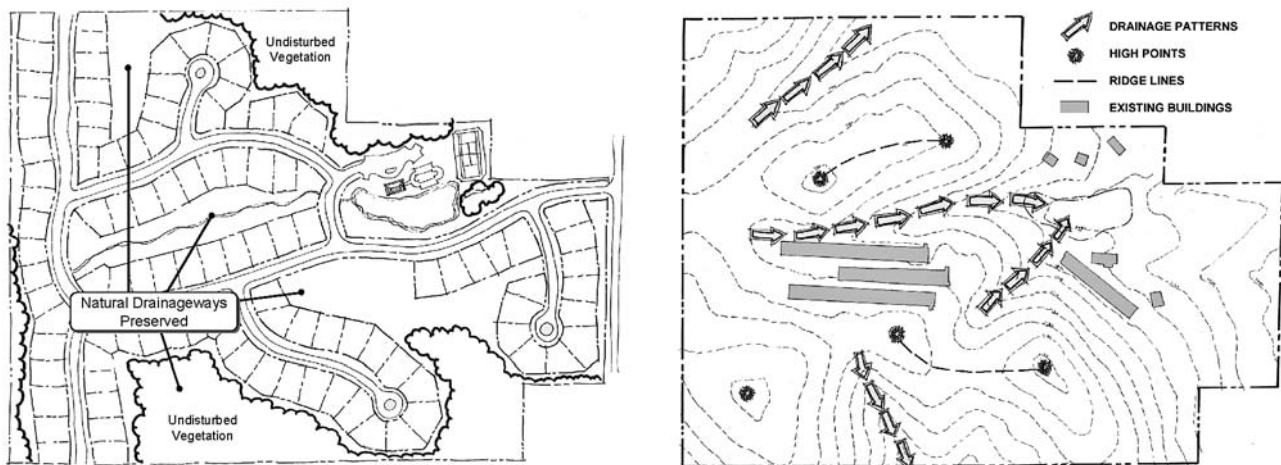

Source: Georgia Stormwater Management Manual, 2001

Planning, Design, and Layout

Incorporating natural drainageways into a site plan requires identifying natural drainage patterns such as overland flow and swales and conveyance systems where water will concentrate. Where possible, these natural drainage features should be integrated into the location and design of storm water management measures, especially around critical areas where water will concentrate. Natural drainage features should also be used to convey storm water runoff over and off the site to avoid the expense and issues associated with constructing an artificial drainage system.

Drainage System

The planning and design of a project's primary drainage system must take into consideration expected storm water runoff volumes and velocities from the final land use. It is critical that the drainage system be planned and designed to accommodate increased runoff from the project

NATURAL DRAINAGEWAYS VS. STORM SEWERS

site. It is also critical to design a conveyance system that will be resistant to the erosive forces created by increased storm water runoff volumes and velocities.

At this stage of planning and design, it is often advantageous to begin evaluating potential sites for detention/retention ponds.

Secondary Drainage System

Secondary drainage systems associated with a project site also require careful evaluation. Where feasible, choose natural or constructed, vegetated drainage swales over a conventional storm sewer system and curbs and gutters. Existing natural drainage swales or constructed grass-lined swales are much more effective in regulating water quality and quantity and are less expensive to construct and maintain than a conventional storm sewer system.

As with the primary drainage system, it is critical that secondary, man-made conveyance systems be properly designed to accommodate expected runoff from the final land use. Again, these secondary, man-made systems will need to be properly stabilized to reduce the erosive forces of storm water runoff. If it is anticipated that runoff flows will increase, route the augmented flow into a man-made storm water conveyance system or detention area and preserve the natural storm water conveyance system.

Natural conveyance systems often have an adjoining floodplain which is used to temporarily store excess storm water runoff and reduce downstream flooding potential. Wherever possible, construction activities and development in floodplains should be avoided. In many instances, floodplains and natural riparian buffer zones can be integrated into the project design to create a level of aesthetic value and/or used as a natural or recreational area. It is also important to preserve natural areas where storm water runoff flow enters the drainage system.

When incorporating natural drainageways into a project's drainage system, it is important to install storm water management measures that will ensure downstream drainageways are protected from erosion, degradation, and high post-development flows from project site storm water discharges.

Occasionally the site designer will propose moving or relocating a natural drainageway. It is important to note that modification or relocation of natural drainageways requires a high level of coordination and generally requires the use of sophisticated storm water quality measures to prevent the discharge of sediment and other pollutants associated with the construction activity. Relocation of natural drainageways can be a costly venture, even if done correctly, and usually requires permits from state and/or federal agencies.

This page was intentionally left blank.