



# Pressure Vessel Explosion at Loy-Lange Box Company



**12**

**Professional Development Hours (PDH) or  
Continuing Education Hours (CE)  
Online PDH or CE course**

# Investigation Report

Published: July 29, 2022



## KEY ISSUES:

- Pressure Vessel Corrosion
- Pressure Vessel Inspection and Regulation
- Pressure Vessel Repair
- Process Safety Management Systems

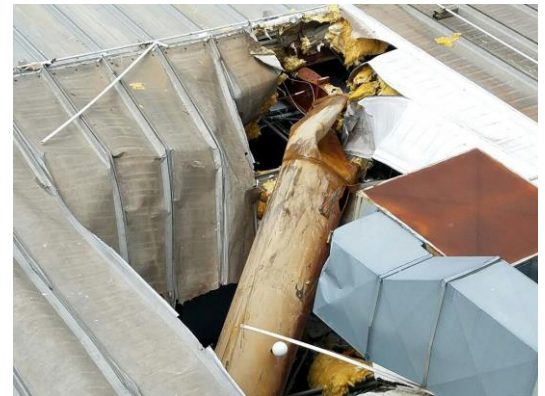



## **U.S. Chemical Safety and Hazard Investigation Board**

**The mission of the U.S. Chemical Safety and Hazard Investigation Board (CSB) is to  
*drive chemical safety change through independent investigations*  
*to protect people and the environment.***

The CSB is an independent federal agency charged with investigating, determining, and reporting to the public in writing the facts, conditions, and circumstances and the cause or probable cause of any accidental chemical release resulting in a fatality, serious injury, or substantial property damages.

The CSB issues safety recommendations based on data and analysis from investigations and safety studies. The CSB advocates for these changes to prevent the likelihood or minimize the consequences of accidental chemical releases.

More information about the CSB and CSB products can be accessed at [www.csb.gov](http://www.csb.gov) or obtained by contacting:

### **U.S. Chemical Safety and Hazard Investigation Board**

1750 Pennsylvania Ave. NW, Suite 910  
Washington, DC 20006  
(202) 261-7600

The CSB was created by the Clean Air Act Amendments of 1990, and the CSB was first funded and commenced operations in 1998. The CSB is not an enforcement or regulatory body. No part of the conclusions, findings, or recommendations of the Board relating to any accidental release or the investigation thereof shall be admitted as evidence or used in any action or suit for damages arising out of any matter mentioned in such report. 42 U.S.C. § 7412(r)(6)(G).

The April 3, 2017, explosion at the Loy-Lange Box Company took the lives of four people:

Tonya Gonzalez, Clifford Lee, Ken Trentham, and Christopher Watkins.

## CONTENTS

FIGURES .....	6
ABBREVIATIONS.....	8
EXECUTIVE SUMMARY .....	9
1 FACTUAL INFORMATION .....	12
1.1 The Loy-Lange Box Company Background .....	12
1.1.1 Stationary Engineers.....	13
1.1.2 Loy-Lange Steam System.....	14
1.1.3 Loy-Lange Steam System History.....	16
1.1.4 Semi-Closed Receiver.....	16
1.2 Oxygen Pitting Corrosion in Steam Systems .....	17
1.3 2012 SCR Repair .....	19
1.4 Boiling Liquid Expanding Vapor Explosions.....	22
1.5 Incident Description .....	22
1.6 SCR Post-Failure Examination .....	26
1.6.1 Visual Examination .....	26
1.6.2 Non-Destructive Thickness Examination.....	29
1.6.3 Destructive Thickness and Metallurgical Examination.....	31
1.7 Loy-Lange Operation Practices.....	34
1.7.1 Loy-Lange Water Treatment Practices .....	34
1.7.2 Loy-Lange Startup Practices.....	35
1.7.3 Loy-Lange Blowdown Practices.....	40
1.8 Process Safety .....	40
1.8.1 Mechanical Integrity.....	41
1.8.2 Inspection.....	42
1.8.3 Incident Investigation .....	43
1.8.4 Hazard Analysis.....	43
1.9 The City of St. Louis and Pressure Vessels .....	44
1.9.1 City Requirements.....	44
1.9.2 City Code Enforcement .....	44
1.9.3 City Inspection Procedures .....	45
1.9.4 City Records .....	45
1.9.5 City Resource Limitations .....	46

1.10	Description of Surrounding Area.....	47
1.11	Weather at Time of Incident .....	48
1.12	Cardboard Corrugation and Pressure Vessels in the United States .....	48
2	INCIDENT ANALYSIS .....	49
2.1	Pressure Vessel Corrosion .....	49
2.1.1	<i>SCR Metallurgical Examination Findings</i> .....	49
2.1.2	<i>BLEVE</i> .....	52
2.1.3	<i>Presence of Dissolved Oxygen</i> .....	52
2.2	Pressure Vessel Inspection and Regulation .....	55
2.2.1	<i>Pressure Vessel Inspection Requirements and Guidance</i> .....	55
2.2.2	<i>Regulatory Jurisdiction</i> .....	58
2.2.3	<i>Absence of SCR Installation and Repair Permits</i> .....	59
2.2.4	<i>City of St. Louis Inspection Requirements</i> .....	60
2.2.5	<i>Absence of SCR Mechanical Integrity Program</i> .....	60
2.2.6	<i>The City of St. Louis Missed Opportunities</i> .....	63
2.2.7	<i>Changes and Gaps in the City of St. Louis Inspection Requirements</i> .....	63
2.2.8	<i>Future Boiler and Pressure Vessel Inspections in the City of St. Louis</i> .....	66
2.3	Pressure Vessel Repair .....	66
2.3.1	<i>The National Board “R-Stamp”</i> .....	67
2.3.2	<i>Inadequacy of the 2012 SCR Repair</i> .....	67
2.3.3	<i>The Repair Inspector</i> .....	71
2.4	Process Safety Management Systems .....	73
2.4.1	<i>Process Safety</i> .....	73
2.4.2	<i>Records Retention</i> .....	77
3	CONCLUSIONS.....	78
3.1	Findings.....	78
3.2	Cause.....	80
4	RECOMMENDATIONS .....	81
4.1	The Loy-Lange Box Company.....	81
4.2	The City of St. Louis Board of Aldermen .....	81
4.3	The Mayor of the City of St. Louis .....	81
4.4	Arise, Inc .....	82

4.5 The National Board of Boiler and Pressure Vessel Inspectors ..... 82

5 KEY LESSONS FOR THE INDUSTRY ..... 82

6 REFERENCES ..... 84

APPENDIX A—CAUSAL ANALYSIS (ACCIMAP)..... 86

APPENDIX B—STEAM PLUME ANALYSIS ..... 87

APPENDIX C—LOY-LANGE PERSONAL SAFETY PROGRAM ..... 91

APPENDIX D—DEMOGRAPHIC INFORMATION FOR LOY-LANGE SURROUNDING AREA..... 92

# Figures

<b>Figure 1.</b> Loy-Lange Box Company, 1904 office building.....	12
<b>Figure 2.</b> Simplified process flow diagram of a typical Clayton steam system .....	14
<b>Figure 3.</b> Pre-incident photo of the Loy-Lange steam generation equipment.....	15
<b>Figure 4.</b> Diagram of SCR.....	16
<b>Figure 5.</b> Pitting corrosion in a boiler tube .....	18
<b>Figure 6.</b> Types of pitting corrosion damage .....	18
<b>Figure 7.</b> Conceptual diagram showing repair made to SCR bottom head in 2012. ....	19
<b>Figure 8.</b> R-1 form documenting the 2012 SCR repair.....	21
<b>Figure 9.</b> Surveillance video still capturing explosion.....	23
<b>Figure 10.</b> Photos of damage caused by SCR explosion.....	23
<b>Figure 11.</b> Damage from the incident .....	24
<b>Figure 12.</b> Debris map from incident.....	25
<b>Figure 13.</b> Removal of the SCR from Faultless Healthcare Linen facility .....	25
<b>Figure 14.</b> Conceptual illustration of fracture in SCR bottom head.....	27
<b>Figure 15.</b> Photo of failed section of SCR bottom head.....	27
<b>Figure 16.</b> Pitting corrosion damage in SCR bottom head.....	28
<b>Figure 17.</b> Photo of the inside surface of the SCR shell and upper head. ....	29
<b>Figure 18.</b> Conceptual cross-sectional diagram of the SCR bottom head, showing examination findings .....	30
<b>Figure 19.</b> Thickness comparison on either side of patch-to-ring weld. ....	31
<b>Figure 20.</b> Post-Incident metallurgical examination of patch-to-ring weld and fracture.....	32
<b>Figure 21.</b> Weld overlay found in the ring of steel still attached to the shell, cross-sectioned .....	33
<b>Figure 22.</b> Plug weld found in the ring of steel still attached to the shell, cross-sectioned.....	33
<b>Figure 23.</b> Simplified process flow diagram illustrating steam system initial conditions.....	36



<b>Figure 24.</b> Simplified process flow diagram illustrating steam flowing to the steam header.....	37
<b>Figure 25.</b> Simplified process flow diagram illustrating the introduction of make-up water.....	38
<b>Figure 26.</b> Simplified process flow diagram illustrating steady-state conditions.....	39
<b>Figure 27.</b> Conceptual diagram of the SCR bottom head.....	40
<b>Figure 28.</b> Pitting damage in two of Loy-Lange’s steam coils .....	41
<b>Figure 29.</b> Overhead satellite imagery of Loy-Lange's vicinity. Image dated August 2017.....	47
<b>Figure 30.</b> Pitting corrosion damage in SCR bottom head. ....	50
<b>Figure 31.</b> Conceptual cross-sectional diagram of the SCR bottom head, showing examination findings.....	51
<b>Figure 32.</b> Conceptual diagram of the SCR bottom head.....	55
<b>Figure 33.</b> Metallurgical mount examination of a portion of the reused ring. ....	69
<b>Figure 34.</b> Thickness comparison on either side of patch-to-ring weld. ....	70
<b>Figure 35.</b> The CCPS Risk-Based Process Safety Management System.....	76
<b>Figure 36.</b> Steam plume comparison. ....	89
<b>Figure 37.</b> Census tracts in the approximately one-mile distance from the Loy-Lange facility.....	92

## Abbreviations

API	American Petroleum Institute
ASME	American Society of Mechanical Engineers
BLEVE	boiling liquid expanding vapor explosion
BPVC	Boiler and Pressure Vessel Code
CSB	U.S. Chemical Safety and Hazard Investigation Board
DCS	distributed control system
FFSA	fitness for service assessment
ICC	International Code Council
IMC	International Mechanical Code
MAWP	maximum allowable working pressure
NBBI	National Board of Boiler and Pressure Vessel Inspectors
NBIC	National Board Inspection Code
OSHA	U.S. Occupational Safety and Health Administration
RAGAGEP	Recognized and Generally Accepted Good Engineering Practice
psi	pounds per square inch
psig	pounds per square inch gauge
SCR	Semi-Closed Receiver
UT	ultrasonic thickness

## Executive Summary

On April 3, 2017, an explosion occurred at the Loy-Lange Box Company (Loy-Lange) in St. Louis, Missouri. The incident occurred when the bottom head of a pressure vessel called a Semi-Closed Receiver, which was used in Loy-Lange's steam system, catastrophically failed. The pressure vessel failure caused a boiling liquid expanding vapor explosion (BLEVE) which fatally injured the Loy-Lange employee working nearby and launched the pressure vessel from the Loy-Lange building into the air. The vessel eventually crashed through the roof of a nearby business, fatally injuring three members of the public.

The St. Louis Fire Department responded to the incident. In addition to the U.S. Chemical Safety and Hazard Investigation Board (CSB), the U.S. Occupational Safety and Health Administration (OSHA) investigated the incident.

## Safety Issues

The CSB's investigation identified the following safety issues:

- **Pressure Vessel Corrosion.** Oxygen pitting corrosion and generalized corrosion thinned the pressure vessel bottom head until it could no longer contain the pressure inside the vessel. Aspects of Loy-Lange's operation directly caused or failed to prevent the corrosion: Loy-Lange's startup practices likely introduced oxygenated water into the SCR daily, and its inadequate water treatment failed to eliminate dissolved oxygen from the water. ([Section 2.1](#))
- **Pressure Vessel Inspection and Regulation.** Pressure vessels are used across nearly all manufacturing sectors, including steam production, refining, petrochemical manufacturing, pulp and paper, and many other industries. Industry codes, guidance, and regulations provide methods to inspect and maintain pressure vessels safely, as pressure vessel failures can be catastrophic, as demonstrated by this incident. Loy-Lange was aware of corrosion in the SCR as early as 2004. Loy-Lange, however, had no mechanical integrity or inspection program, as recommended within industry guidance documents, to monitor or mitigate corrosion in the SCR. The City of St. Louis was the regulatory authority responsible for inspecting pressure vessels in the city. However, due to manpower limitations and Loy-Lange's deficient regulatory compliance, the City never inspected the SCR. ([Section 2.2](#))
- **Pressure Vessel Repair.** A repair made to the SCR in 2012 by Kickham Boiler and Engineering, a National Board "R" Certificate holding company, did not adhere to applicable National Board Inspection Code requirements because Kickham likely left material in place that was thinner than the SCR's required minimum thickness. Only a portion of the corroded pressure vessel bottom head was replaced, leaving the compromised remaining portion of the head in place to continue corroding. This remaining portion of original steel failed on April 3, 2017, initiating the explosion. Arise, the Authorized Inspection Agency for Kickham's repair, did not detect Kickham's inadequate repair. When repairing a pressure vessel, it is essential to remove all unacceptably damaged material. Repair companies and inspectors must ensure that such material is fully removed. ([Section 2.3](#))
- **Process Safety Management Systems.** Loy-Lange did not establish a strong process safety culture and did not have programs that could have identified the hazards or analyzed and mitigated the risks of its

FDA, Inc.

operations. Such programs could have enabled Loy-Lange to learn from its operational experience. Loy-Lange, however, did not employ sound process safety management principles in addressing the risks associated with corrosion in its steam process. It is essential that facilities with hazardous processes have an effective process safety management system to help ensure major incidents such as the Loy-Lange incident are prevented. ([Section 2.4](#))

## Cause

The CSB determined that the cause of the explosion was deficiencies in Loy-Lange's operations, policies, and process safety practices that failed to prevent or mitigate chronic corrosion in its Semi-Closed Receiver and Kickham Boiler and Engineering's performance of an inadequate repair to the SCR in 2012 that left damaged material in place. Contributing to the incident was the City of St. Louis's missed opportunities to identify and ensure the inspection of the SCR, Arise's acceptance of and failure to detect Kickham's inadequate repair, and gaps in Arise's and the National Board of Boiler and Pressure Vessel Inspectors' repair inspection requirements.

## Recommendations

### To the Loy-Lange Box Company

Develop and implement a comprehensive safety management system. Include in that system process safety elements recommended in industry guidance publications, such as the Center for Chemical Process Safety (CCPS) publication *Guidelines for Risk Based Process Safety*.

Engage a qualified third-party to conduct a comprehensive review or audit of Loy-Lange's regulatory compliance practices and current compliance status.

Implement an electronic records and data management system that preserves all critical company records, safety policies and procedures, and operational data. Ensure that such records are stored and can be accessed remotely in the event of a catastrophic incident.

### To the City of St. Louis Board of Aldermen

Revise the City of St. Louis Mechanical Code to adopt a national consensus standard such as NBIC Part 2 to govern the requirements for inservice inspection of boilers and pressure vessels.

Revise the City of St. Louis Mechanical Code to require pressure vessel inspections be performed by an NBBI inservice (IS) commissioned inspector.

### To the Mayor of the City of St. Louis

Distribute and communicate the findings of this report to all licensed stationary engineers and all registered boiler and pressure vessel owning/operating entities in the City of St. Louis.

### To Arise

Update company policies and/or procedures by including prescriptive elements in the boiler and pressure vessel repair and alteration inspection and acceptance process that would prevent the acceptance of a non-conforming repair or alteration.

**To the National Board of Boiler and Pressure Vessel Inspectors**

Update *NB-263 Rules for Commissioned Inspectors* to include prescriptive elements in the boiler and pressure vessel repair and alteration inspection and acceptance process that would prevent the acceptance of a non-conforming repair or alteration.

# 1 Factual Information

This section details the facts gathered by the CSB investigation team.

## 1.1 The Loy-Lange Box Company Background

Lincoln K. Loy and Edward Lange founded the Loy-Lange Box Company in 1897, and in 1904 the company moved into a two-story brick factory building in St. Louis, Missouri (**Figure 1**), where the 2017 incident occurred [1]. According to Loy-Lange, at the time of the incident, Loy-Lange employed 71 people at its facility and currently employs 77 people.



**Figure 1.** Loy-Lange Box Company, 1904 office building. (Credit: St. Louis Fire Department)

At the time of the incident, Loy-Lange manufactured corrugated cardboard,<sup>a</sup> which it then used to manufacture other products, such as cardboard boxes and retail product displays. At Loy-Lange, the corrugated cardboard manufacturing process (“corrugation process”) was continuous, with rolls of paper feeding in at the beginning of the process and running through a series of machines, and the corrugated cardboard product emerging from the end. During the manufacturing process, the paper used to make the corrugated cardboard required heating, discussed below in Section 1.1.2.

---

<sup>a</sup> Corrugated cardboard is made by combining multiple sheets of a special grade of paper called *containerboard*. The ubiquitous “single-wall” style consists of a corrugated, or fluted, sheet of containerboard sandwiched between two flat sheets [40] [37].

### 1.1.1 Stationary Engineers

Loy-Lange employed licensed stationary engineers to operate its steam system. The City of St. Louis uses the term *stationary engineers* to refer to licensed boiler operators [2]. The qualifications for a stationary engineer license at the time of this incident were as follows:

#### Stationary Engineer Class I

- Two years of experience training under a Class I stationary engineer or equivalent training; or
- Registered with the state of Missouri as a Professional Engineer or as an Engineer in Training, with 12 months of experience in a steam-generating facility in an engineering capacity or 12 months of formal education by a “nationally recognized agency.”<sup>a,b</sup>

#### Stationary Engineer Class II

- One year of experience in the operations of steam boilers or steam generators under the supervision of a Class I or II stationary engineer or equivalent training; or
- One year of experience in maintenance work on steam boilers, steam engines, steam turbines, or ammonia systems in excess of 50-tons capacity; or
- Registered with the state of Missouri as a Professional Engineer or as an Engineer in Training.
- In lieu of up to 12 months experience, the city accepts 12 months of formal training by a “nationally recognized agency.”<sup>c,d</sup>

Stationary engineers must pass a test given by the city to obtain licensure. Loy-Lange employed three stationary engineers at the time of the incident. All three took a 12-month course in stationary engineering from a local technical school, trained under a Class I stationary engineer, passed the certification exam given by the City of St. Louis Board of Stationary Engineers, and obtained Class I Stationary Engineer licensure. The Loy-Lange stationary engineers’ licensure qualified them to safely operate boilers and pressure vessels but did not qualify them to fabricate boilers or pressure vessels, perform inspections, or perform repairs or alterations per regulatory and applicable code requirements, as those tasks each require separate certifications from other organizations.

In this report, *stationary engineer* and *operator* are used interchangeably.

---

<sup>a</sup> [St. Louis, Missouri, Municipal Code § 68639-110.6.](#)

<sup>b</sup> “Agency” is the language used in the ordinance, but such education was not provided by any agency of the City of St. Louis. Instead, training and education were to be provided by an approved third-party provider.

<sup>c</sup> [St. Louis, Missouri, Municipal Code § 68639-110.6.](#)

<sup>d</sup> “Agency” is the language used in the ordinance, but such education was not provided by any agency of the City of St. Louis. Instead, training and education were to be provided by an approved third-party provider.

### 1.1.2 Loy-Lange Steam System

To produce the heat required in the corrugation process, Loy-Lange used a steam generation system. Loy-Lange had two steam generators, operating one of them at any given time. The water fed to the steam generators included water from the city water supply as well as returned condensate from the corrugation process. A process flow diagram of the Loy-Lange steam system is shown in **Figure 2**.

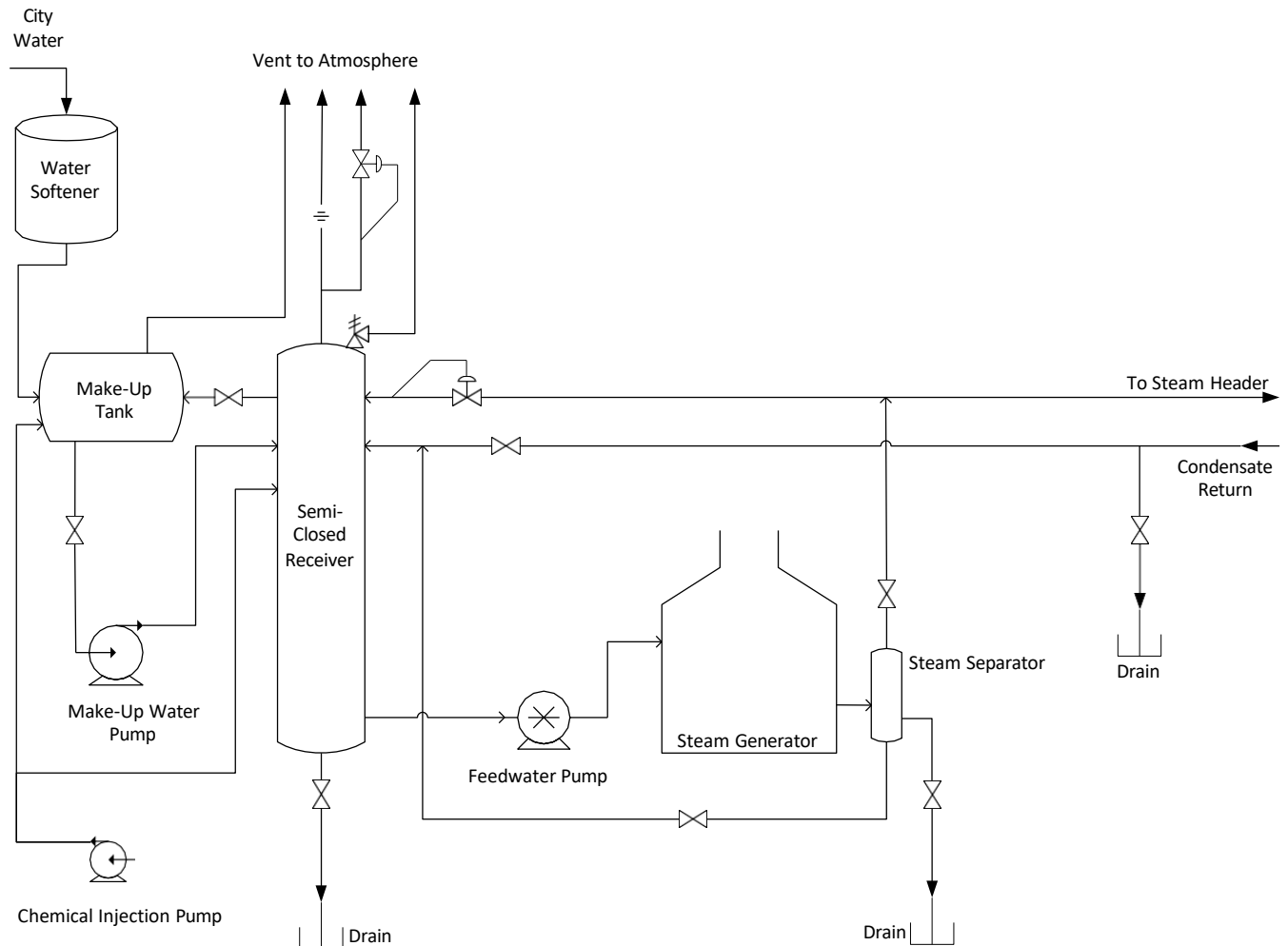

**Figure 2.** Simplified process flow diagram of a typical Clayton steam system. (Credit: CSB)

In the Loy-Lange steam system, water from the city water supply was fed through a water softening system<sup>a</sup> and into a tank called a *make-up tank*, which was held at atmospheric pressure. The water in the make-up tank was mechanically deaerated by adding heat and chemically deaerated by injecting various water treatment chemicals. These deaeration processes were designed to remove dissolved oxygen and other non-condensable gases from the incoming softened water, which, if not adequately controlled, can cause corrosion and premature steam

<sup>a</sup> Many industrial steam systems include water softening. Water softeners are used to remove naturally occurring minerals [36, pp. 1-5] from the water that can deposit onto boiler tubes and generator coils when the water is boiled. Such deposits can decrease system energy efficiency and can lead to premature component failure [36, p. 87].



system component failure. The water was then pumped from the make-up tank into a pressure vessel called a *Semi-Closed Receiver*, or SCR.<sup>a</sup> This vessel received both the incoming softened, deaerated water and the condensate returning from the corrugation process. Water in the SCR was further chemically deaerated with additional water treatment chemicals. Water was then pumped from the SCR to the steam generators, where it flowed through a coil and was heated by burner combustion gases, and it then entered a vessel called a *steam separator*. In this vessel, most of the water evaporated into steam and any water that did not was drained.

The steam then flowed to the corrugation process and provided heat to the process equipment, whereupon it condensed back into liquid. Because there was little pressure reduction<sup>b</sup> in the steam from the corrugation process, the condensate returned to the feedwater system (into the SCR) at near saturation temperature and pressure. The SCR was held under pressure, which allowed the feedwater and returning condensate to retain more heat than at atmospheric pressure, resulting in a more energy-efficient system.

A pre-incident picture of the Loy-Lange steam generation room is shown below in **Figure 3**, which also shows the close proximity of the SCR to one of the steam generators.

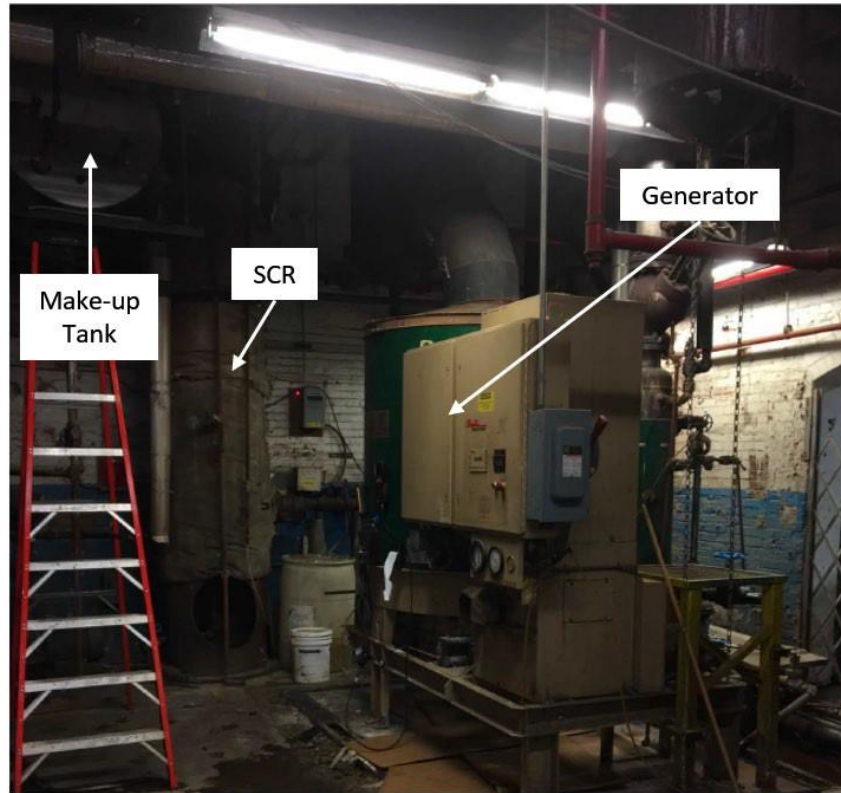

**Figure 3.** Pre-incident photo of the Loy-Lange steam generation equipment. (Credit: Clayton. Annotated by CSB.)

<sup>a</sup> The pressure vessel was called “semi-closed” because it was equipped with a vent line that allowed air and other non-condensables, along with a small amount of steam, to vent to atmosphere continuously via a ¼-inch orifice and periodically via a mechanical back pressure regulating valve.

<sup>b</sup> The steam typically only provided heat to the corrugation process. The steam did no work, such as by driving a turbine, which resulted in little pressure reduction in the steam and resulting condensate.

### 1.1.3 Loy-Lange Steam System History

The two steam generators at the Loy-Lange facility were designed and built by Clayton Industries (Clayton). City of St. Louis records show that Loy-Lange installed two Clayton steam generators, one in 1966 and the other in 1968. Loy-Lange began upgrading its steam system in 1997 by adding the SCR, also designed by Clayton. In 1999 and 2001, the original steam generators were replaced with newer Clayton models.

The Loy-Lange steam system was typically in operation during the day shift, Monday through Friday, matching the operating cycles of the corrugation process. The steam system was started up in the morning and shut down at the end of the day each weekday, and it remained shut down over weekends.

### 1.1.4 Semi-Closed Receiver

The Loy-Lange SCR was a cylindrical pressure vessel with an outside diameter of 30 inches and a length of about 17.5 feet (**Figure 4**). The SCR was mounted roughly three feet above grade on top of a support cylinder, or *skirt*. The cylindrical center portion of a pressure vessel is called the *shell*, and the pieces that enclose the ends of the shell are called *heads* [3]. The SCR was located near one of the steam generators (**Figure 3**).

According to the vessel's U-1A form,<sup>a</sup> the SCR was designed by Chicago Boiler with a nominal thickness of 0.250 inches, a maximum allowable working pressure (MAWP) of 150 psi, and a maximum design temperature of 450°F. Additionally, it was designed for non-corrosive service and was designed with no corrosion allowance. The upper and lower heads of the SCR were designed and fabricated with a 2:1 elliptical ratio. The SCR's design minimum thickness<sup>b</sup> was 0.2204 inches. According to Clayton, the SCR was originally equipped with a pressure relief valve set at 150 psi. After the incident, the SCR was found to be

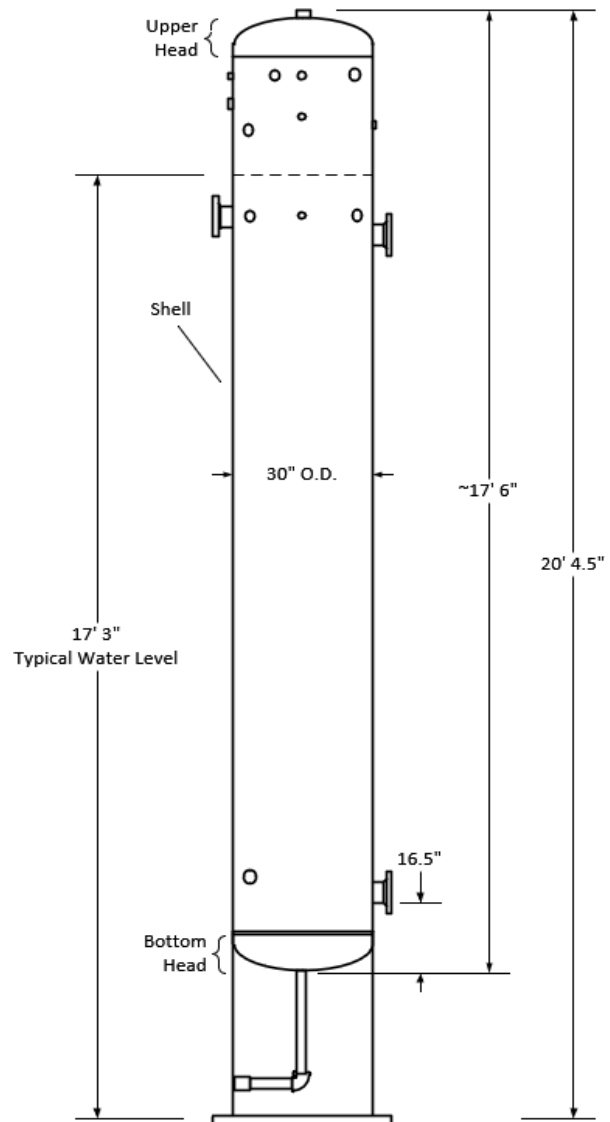

**Figure 4.** Diagram of SCR. (Credit: Clayton, edited by CSB)

<sup>a</sup> A U-1A form is a standard form that the American Society of Mechanical Engineers (ASME) Boiler and Pressure Vessel Code (BPVC) Section VIII requires pressure vessel fabricators to complete [38, p. 91]. The form contains relevant design information for a pressure vessel, including its nominal thickness, its maximum allowable working pressure, its National Board of Boiler and Pressure Vessel Inspectors (NBBI) registration number, and other important design information [38, pp. 612, 630-634].

<sup>b</sup> Referred to in ASME BPVC Section VIII as the *required thickness*. Specified by the code, this is the thickness required to safely contain pressure at a vessel's design conditions [38, pp. 20-21, 404].

equipped with a pressure relief valve set at 200 psi. The SCR typically contained water at around 100 psig and 330°F.<sup>a</sup>

The SCR was operated mostly full of water, with the water level typically within three feet of the SCR top. Two pipes, connected to the vessel about a foot below the water level, supplied water to the SCR. One pipe supplied returning condensate from the corrugation process, and the other supplied make-up water from the make-up tank. A level controller modulated the flow of make-up water into the SCR to maintain the water level inside the SCR.

The SCR fed the steam generator feedwater pump via a 4-inch outlet nozzle situated roughly 1.5 feet above the bottom of the SCR bottom head. The liquid below this nozzle did not flow during normal operation. Operators could achieve flow through the bottom portion of the vessel by opening a manual drain valve within a pipe attached to the bottom head. This procedure is called *blowing down* the SCR.

## 1.2 Oxygen Pitting Corrosion in Steam Systems

Oxygen pitting corrosion is a widely known damage mechanism that occurs in steam systems [4, p. 42]. Dissolved oxygen in steam system feedwater can cause corrosion in steel, typically appearing as pitting (**Figure 5**) [4, p. 42] [5, p. 54]. As shown in **Figure 6**, pitting corrosion damage can assume multiple different shapes [6].

To prevent oxygen pitting corrosion in steam systems, dissolved oxygen must be removed from the steam system water [4, p. 42] [5, p. 54]. Loy-Lange employed both mechanical deaeration (heating water to remove oxygen) and chemical deaeration (injecting chemicals called *oxygen scavengers*, such as sodium sulfite or hydrazine [4, p. 43]), into water to react with dissolved oxygen to render it chemically unavailable to cause corrosion [7, pp. 75-81] (refer to Section 1.7.1 below). These two strategies are typically used in tandem to remove dissolved oxygen from water [8].

---

<sup>a</sup> According to Loy-Lange's OSHA citation letter [46]. Loy-Lange's OSHA citations resulting from this incident can be found on OSHA's website here: [https://www.osha.gov/pls/imis/establishment.inspection\\_detail?id=1221846.015](https://www.osha.gov/pls/imis/establishment.inspection_detail?id=1221846.015)



**Figure 5.** Pitting corrosion in a boiler tube. (Credit: U.S. Dept. of Defense [5, p. 38])

**Types of Pitting Corrosion:**

Trough Pits:



Sideway Pits:

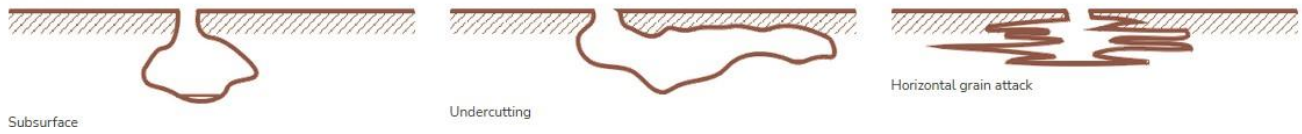

**Figure 6.** Types of pitting corrosion damage. (Credit: AMPP [6])

### 1.3 2012 SCR Repair

In November of 2012, Loy-Lange stationary engineers detected water leaking from the bottom head of the SCR. The company discussed whether to replace or repair the vessel. The company contracted Kickham Boiler and Engineering Inc. (Kickham) to repair the leaking SCR. The SCR was registered with the National Board of Boiler and Pressure Vessel Inspectors (NBBI).<sup>a</sup> Kickham held an NBBI *R Certificate of Authorization* (commonly referred to in industry as an “*R-Stamp*”), which authorized Kickham to perform repairs and alterations to pressure vessels and other pressure-retaining components in accordance with the National Board Inspection Code (NBIC).<sup>b</sup>

As illustrated in **Figure 7**, Kickham cut the SCR shell from the bottom head, leaving the bottom head attached to the skirt. With the bottom head and skirt removed from the SCR shell, Kickham inspected the inside surface of the SCR. A Kickham employee who oversaw the repair said Kickham observed pitting corrosion damage in the bottom head.

The employee said that the corrosion pits were isolated in the center of the head.

With access to the inside surface of the bottom head, Kickham cut out a circular portion of the center of the bottom head. According to a Kickham employee, the size of the circular portion was chosen to remove all the pitting and corrosion damage. The Kickham employee also told CSB investigators that the repair removed all corrosion damage in the SCR bottom head. In interviews, CSB investigators asked whether Kickham did any ultrasonic thickness (UT) measurement during the course of its repair. CSB investigators also asked whether Kickham inspected visually or used a micrometer.

The Kickham employee replied:

<sup>a</sup> Registration with NBBI certifies that a pressure vessel was fabricated in accordance with the ASME BPVC [35].

<sup>b</sup> The NBIC is authored by NBBI [16].

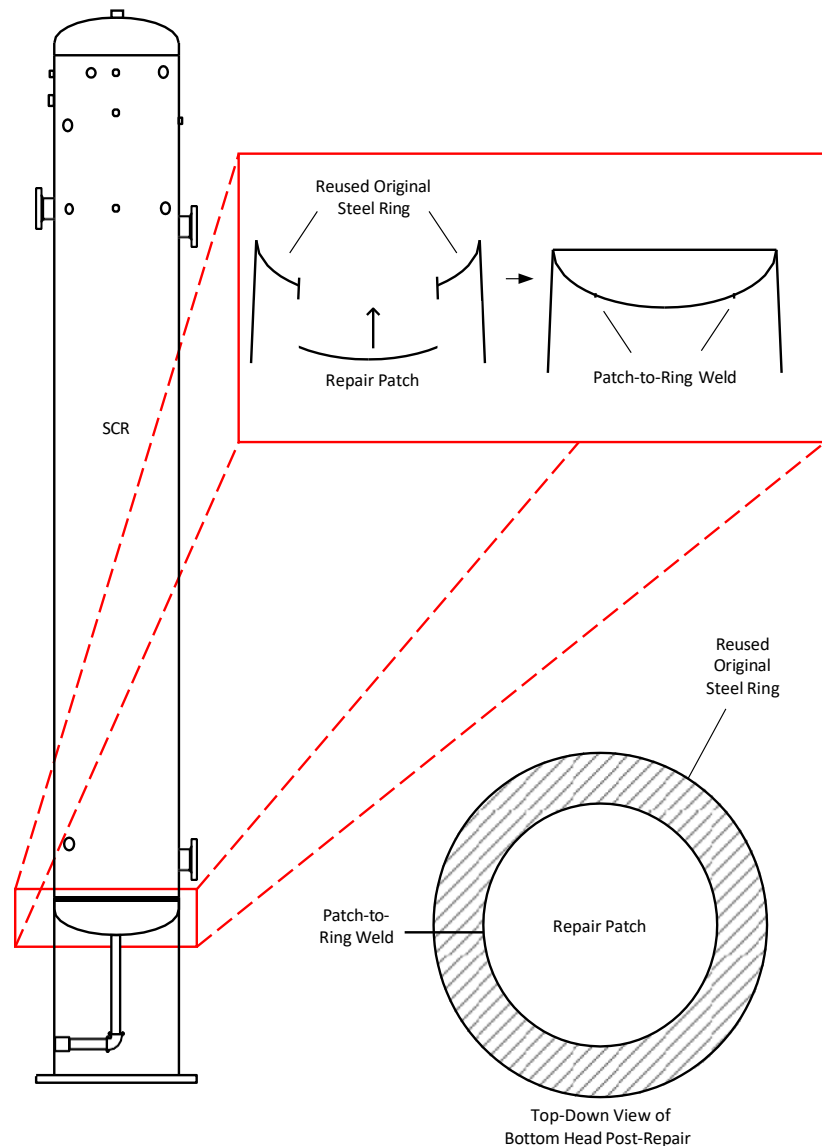

**Figure 7.** Conceptual diagram showing repair made to SCR bottom head in 2012. (Credit: CSB)

“No. You can see the pits. They’re obvious, and when they’re in the center of the head, and isolated at the center, and you can see where they stop, you can decide how big the patch plate should be in order to take out all the bad corroded area. And when you make the cut, you make that cut, now you get to see the thickness of the existing steel. [...] So when you do your flush patch you bring in your new quarter inch thick plate, and it matches up to the existing quarter inch thick plate, and it’s a nice match, you’re confident that you’re welding quarter inch to quarter inch, and that you’ve replaced all the bad area. That’s a physical measurement you get to measure the thickness of it. [...] [The measurement] would be more with a tape measure than a micrometer. When you put two pieces together, you can feel it, the difference in thickness. The slightest change in thickness you can feel it and see it.

And in a written response to a CSB information request, Kickham wrote:

“[Kickham employee] and [another Kickham employee] measured the thickness of the patch plate and the thickness of the existing metal using a measuring tape and verified the thicknesses matched at ¼ inch.”

When Kickham cut out a circular portion of the bottom head, it left a ring of the original head material still connected to the shell. This report calls this material the “reused original steel ring.” Kickham welded the new patch plate (termed the “repair patch” in the remainder of this report) to the reused original steel ring of the bottom head.<sup>a</sup> Kickham then rewelded the bottom head and skirt assembly to the SCR shell. Kickham told the CSB that when workers welded the patch in, the metal to which they were welding (the reused original steel ring) was of nominal thickness (0.250 inches). Kickham and Loy-Lange conducted a post-repair hydrostatic pressure test on the SCR prior to returning it to service. The test was conducted using water at 110 psig.

After the incident that is the subject of this report, Kickham told the CSB that Kickham did not fabricate ellipsoidal heads, such as the SCR bottom head. Kickham also told the CSB that Loy-Lange requested an “emergency repair,” and Kickham interpreted this request to mean that Loy-Lange desired the repair to be completed immediately, presumably so that Loy-Lange could start the system up again the following Monday. To perform the repair, Kickham bent a steel plate so that it would fit the SCR, in lieu of fabricating or purchasing an ellipsoidal head.

During the course of the repair, an NBBI-authorized Repair Inspector, employed by Arise, was involved as required by NBBI code. The Repair Inspector designated no inspection points, did not witness the repair in progress, and only witnessed the vessel’s pressure test upon its return to service.

Upon completion of the 2012 repair, Kickham and the Repair Inspector documented the repair by completing an *R-1 Report of Repair* form. The R-1 form can be seen below in **Figure 8**:

---

<sup>a</sup> Kickham welded the new patch plate to the reused original steel ring by applying a weld to both the top (inside surface) and bottom (outside surface) of the head.

FORM R-1 REPORT OF REPAIR  
in accordance with provisions of the National Board Inspection Code

1. Work performed by Kickham Boiler & Engineering Inc.  
(name of repair organization)  
625 E. Carrie Ave.

(Form Registration No.)  
[Redacted]  
(PO No., Job No., etc.)

2. Owner Loy Lange Box Co  
(name)  
222 Russell Blvd St. Louis MO  
(address)

3. Location of installation same as # 2 above  
(name)  
(address)

4. Item Identification Vessel  
(boiler, pressure vessel or piping) Name of original manufacturer Chicago Boiler Co.

5. Identifying nos.: 979076 8367 unknown 34085A 1997  
(mfg serial no.) (National Board No.) (Jurisdiction No.) (other) (year built)

6. NBIC Edition/Addenda: 2011 None  
(edition) (addenda)

Original Code of Construction for Item: ASME Section VIII Division 1 1995 / 12-95  
(name/section/division) (edition/addenda)

Construction Code Used for Repair Performed: ASME Section VIII Division 1 2010 Edition, 2011 Addenda  
(name/section/division) (edition/addenda)

7. Repair Type:  Welded  Graphite Pressure Equipment  FRP Pressure Equipment  
 Form R-4, Report Supplementary Sheet is attached  FFSA Form (NB-403) is attached

8. Description of work:  
(use Form R-4, if necessary)  
Cut bottom head off of Vessel with skirt attached. Cut out center section of bottom head. install new piece of SA-516-70, 1/4" 24" dia.  
New section formed at the shop. Butt weld on head patch is welded both sides. Head to shell is welded with backing strip same as original.  
Hydro by KBE and Inservice Pressure Test, if applied 110 psi MAWP 150 psi

9. Replacement Parts. Attached are Manufacturer's Partial Data Reports or Form R-3s properly completed for the following items of this report:  
  
(name of part, item number, data report type or Certificate of Compliance, mfg. name, and identifying stamp)

10. Remarks:

**CERTIFICATE OF COMPLIANCE**

I, [Redacted], certify that to the best of my knowledge and belief the statements in this report are correct and that all material, construction, and workmanship on this Repair conforms to the National Board Inspection Code.  
National Board "R" Certificate of Authorization No. [Redacted] expires on [Redacted]

Date 11/20/2012 Kickham Boiler & Engineering Inc. Signed [Redacted]  
(name of repair organization)

**CERTIFICATE OF INSPECTION**

I, [Redacted], holding a valid Commission issued by The National Board of Boiler and Pressure Vessel Inspectors and certificate of competency, where required, issued by the Jurisdiction of Missouri and employed by ARISE of Brecksville OH have inspected the work described in this report on 11/20/2012 and state that to the best of my knowledge and belief this work complies with the applicable requirements of the National Board Inspection Code.  
By signing this certificate, neither the undersigned nor my employer makes any warranty, expressed or implied, concerning the work described in this report. Furthermore, neither the undersigned nor my employer shall be liable in any manner for any personal injury, property damage or loss of any kind arising from or connected with this inspection.

Date 11/20/2012 Signed [Redacted] Commissions [Redacted]  
(National Board and Jurisdiction No.)

Figure 8. R-1 form documenting the 2012 SCR repair. (Credit: Kickham)

In December 2012, after the repair, Kickham emailed a proposal to the Loy-Lange plant manager. Kickham proposed fully replacing the bottom head of the SCR and the bottom four feet of the SCR shell with 3/8-inch-thick material. In discussing the December proposal, a Kickham employee told the CSB that he recalled alerting Loy-Lange to the occurrence of corrosion in the SCR.

## 1.4 Boiling Liquid Expanding Vapor Explosions

When a pressure vessel stores a liquid at temperatures greater than its atmospheric boiling point, the potential for a boiling liquid expanding vapor explosion (BLEVE) exists. According to the Center for Chemical Process Safety (CCPS), a BLEVE is defined as “a sudden loss of containment of a pressure-liquefied gas existing above its normal atmospheric boiling point at the moment of its failure, which results in rapidly expanding vapor and flashing liquid [9, p. 311].” A BLEVE requires three components:

- 1) a liquid that exists above its normal atmospheric pressure boiling point;
- 2) containment that causes the pressure on the liquid to be sufficiently high to suppress boiling; and,
- 3) a sudden loss of containment to rapidly drop the pressure on the liquid [9, p. 311].

A BLEVE can involve any liquid stored under pressure at temperatures above its atmospheric boiling point. The liquid does not need to be flammable for a BLEVE to occur [9, p. 319]. According to CCPS, a BLEVE does not require the vessel’s operating pressure to exceed either the design pressure or the rated working pressure. This phenomenon means that a BLEVE can occur even when the pressure relief device(s) are working correctly. Some of the consequences of a BLEVE include a blast wave due to expansion of vapor and flashing liquid and fragment throw or rocketing of vessel pieces [9, p. 319].

## 1.5 Incident Description

On Friday, March 31, 2017, Loy-Lange stationary engineers observed a leak that appeared to be coming from underneath the SCR. One stationary engineer took photos of the underside of the vessel to confirm the leak. Another contacted a local welding company and requested that it assess the vessel and make a repair recommendation. The welding company was not available to visit the Loy-Lange facility until the following Monday, April 3, 2017. Loy-Lange continued operating the leaking pressure vessel throughout the remainder of the Friday production schedule and shut down the steam system as normal that evening. The following Monday a Loy-Lange stationary engineer began his normal start-up routine at about 6:00 a.m. At around 7:20 a.m. on April 3, 2017, the SCR bottom head catastrophically failed. The SCR was launched from the Loy-Lange building and into the air (**Figure 9, Figure 10**).

The vessel remained airborne for approximately 10 seconds<sup>a</sup> and traveled laterally approximately 520 feet (**Figure 11A, Figure 12**). The SCR fell through the roof of the nearby Faultless Healthcare Linen company one block away, where it came to rest (**Figure 11B**). Various other pieces of debris from the explosion also fell into the surrounding area. A third building in the vicinity, owned by Pioneer Industrial Group, suffered damage when a large piece of pipe from the Loy-Lange explosion punctured the roof and ruptured its water sprinkler system

---

<sup>a</sup> Flight timed from surveillance video.



(**Figure 11C**). A section of 1.5-inch pipe approximately seven feet in length pierced the windshield and embedded in the dashboard and through the floorboard of an unoccupied pickup truck parked in the area (**Figure 11D**). A map of the debris field is shown in **Figure 12**. As a result of the incident, one stationary engineer at Loy-Lange was fatally injured. At Faultless Healthcare Linen, three employees were fatally injured when the SCR fell through the roof.



**Figure 9.** Surveillance video still capturing explosion. (Credit: Kranz Body Co., annotations by CSB)

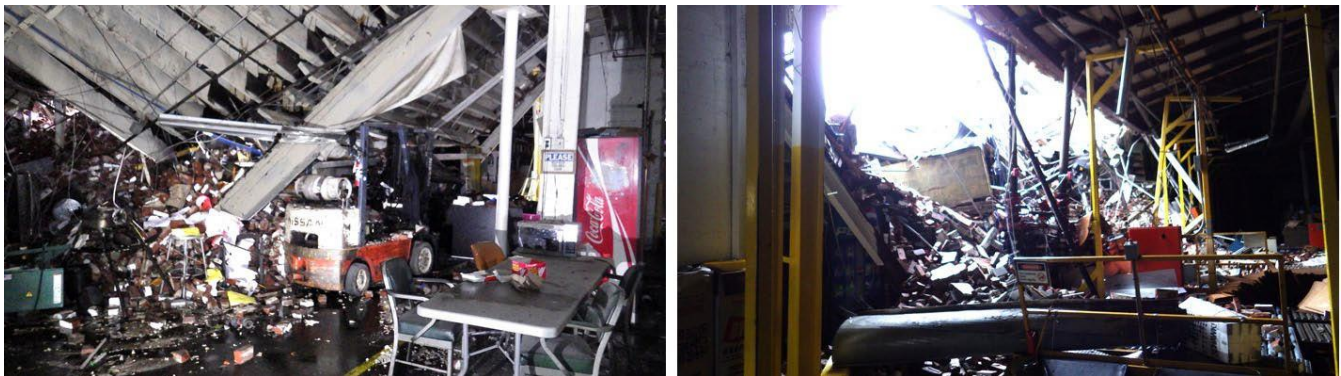

**Figure 10.** Photos of damage caused by SCR explosion. (Credit: St. Louis Fire Department)

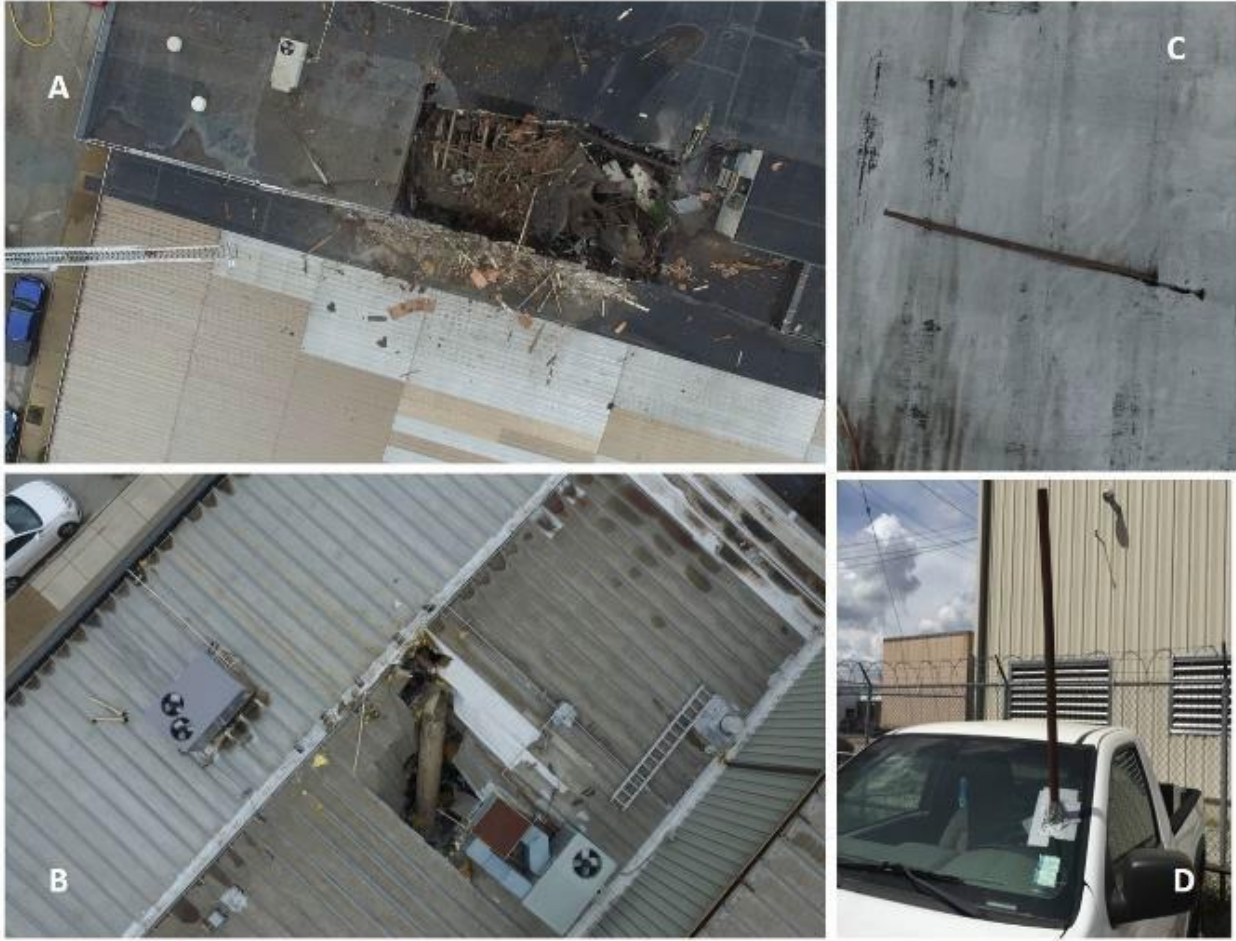

**Figure 11.** Damage from the incident. (Credit A-C: St. Louis Fire Department, D: CSB)



Figure 12. Debris map from incident. (Credit: Google, annotations by CSB)



Figure 13. Removal of the SCR from Faultless Healthcare Linen facility. (Credit: CSB)

## 1.6 SCR Post-Failure Examination

The CSB commissioned post-incident metallurgical examination of the failed SCR pieces, described below.

### 1.6.1 Visual Examination

After the incident, the SCR was found to have separated into two distinct pieces: (1) The shell, upper head, skirt and a small ring of the bottom head, still attached to the shell by the bottom head-to-shell weld, and (2) the rest of the bottom head. As can be seen in **Figure 14** and **Figure 15**, the fracture surface, where the bottom head piece separated from the rest of the vessel, was found to be fully contained within the re-used original steel ring, in the heat affected zone of the patch-to-ring weld made by Kickham in 2012.

Extensive pitting and generalized corrosion damage (**Figure 16**) was found in both the separated portion of the bottom head and in the portion of the bottom head that remained attached to the SCR shell. This pitting and generalized corrosion damage is consistent with the appearance of oxygen pitting and corrosion damage. The shell and upper head were found to be relatively unaffected by corrosion damage, as pictured in **Figure 17**.

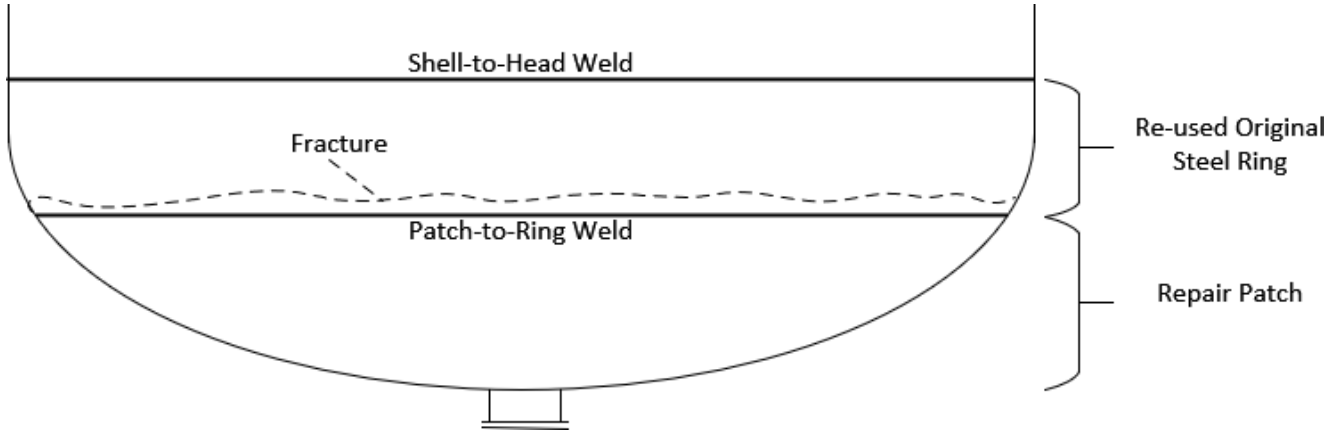

**Figure 14.** Conceptual illustration of fracture in SCR bottom head. (Credit: CSB)

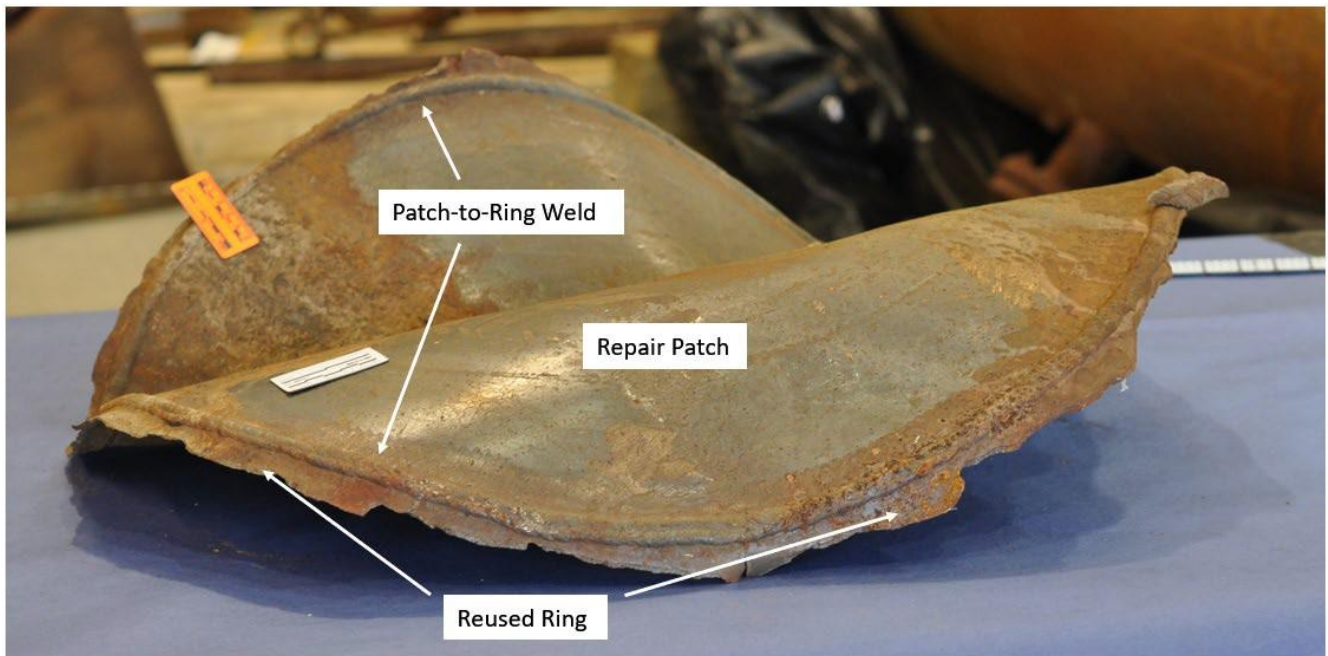

**Figure 15.** Photo of failed section of SCR bottom head. (Credit: CSB)



**Figure 16.** Pitting corrosion damage in SCR bottom head. (Credit: CSB)

FDA, Inc.



**Figure 17.** Photo of the inside surface of the SCR shell and upper head. (Credit: CSB)

### **1.6.2 Non-Destructive Thickness Examination**

The CSB commissioned comprehensive non-destructive thickness examination of the SCR after the incident. Some of the examination findings are illustrated in **Figure 18**. The thickness of adjacent spots on either side of the patch-to-ring weld were measured and compared (**Figure 19**). On average, the repair patch was almost twice as thick as the re-used original steel ring.

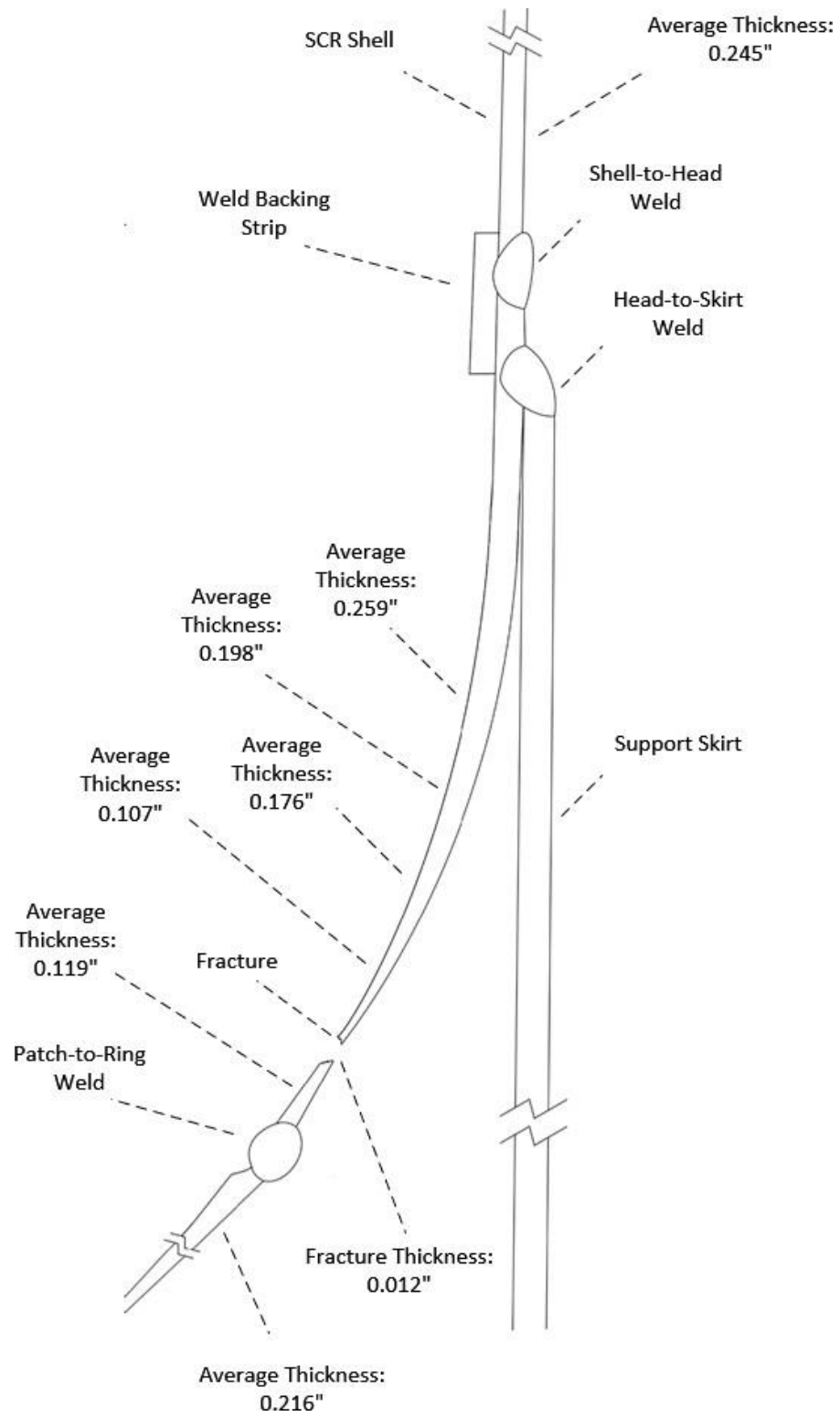

**Figure 18.** Conceptual cross-sectional diagram of the SCR bottom head, showing examination findings. (Credit: CSB)





**Figure 19.** Thickness comparison on either side of patch-to-ring weld. (Credit: CSB)

### 1.6.3 Destructive Thickness and Metallurgical Examination

Destructive thickness examination found that corrosive attack reduced the nominally 0.250-inch steel to 0.012 inches at the thinnest spot measured, a thickness loss of 95 percent (**Figure 20**). The spot that measured 0.012 inches was at the fracture edge, in the re-used ring. The average post-incident thickness of the re-used ring around the periphery of the fracture, as measured by calipers, was 0.107 inches. The examination also discovered four weld repairs in the portion of the re-used ring that remained attached to the shell. These welds were cross-sectioned and examined. Three of the four welds were weld overlays, used to fill in thin spots from the inside of the vessel. The fourth was a plug weld, used to plug a full penetration through the thickness of the head. All four of these welds were made to the ring of bottom head material that remained attached to the SCR shell. A photo documenting one of the weld overlays is shown in **Figure 21**, and photos documenting the plug weld are shown in **Figure 22**.

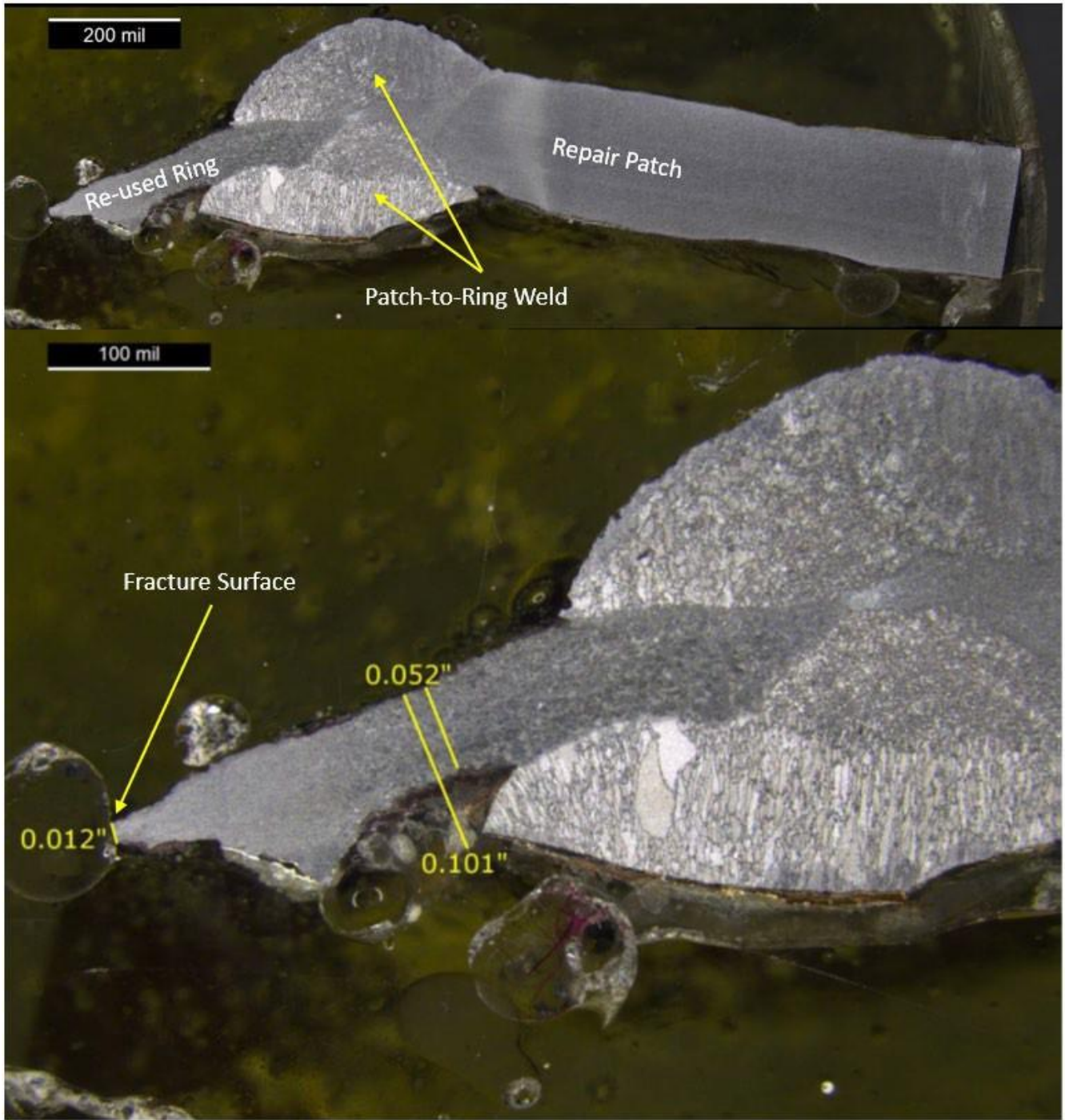
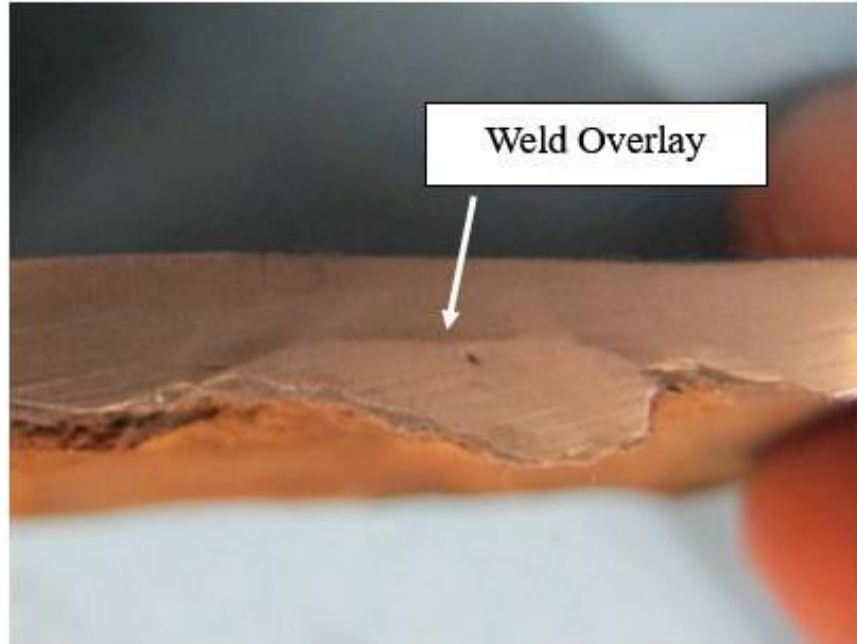

Figure 20. Post-Incident metallurgical examination of patch-to-ring weld and fracture. (Credit: CSB)



**Figure 21.** Weld overlay found in the ring of steel still attached to the shell, cross-sectioned. (Credit: CSB)



**Figure 22.** Plug weld found in the ring of steel still attached to the shell, cross-sectioned. (Credit: CSB)

## 1.7 Loy-Lange Operation Practices

This section describes the water treatment, startup, and SCR blowdown practices used by Loy-Lange preceding the incident.

### 1.7.1 Loy-Lange Water Treatment Practices

Loy-Lange mechanically deaerated the make-up tank water by injecting steam into the tank to heat the water to 190-200°F (see equipment configuration in **Figure 2**). Loy-Lange also chemically deaerated the steam system water by injecting sodium sulfite at two locations: the make-up tank and the SCR.

Loy-Lange employed a contractor to provide water treatment services and expertise, and to supply water treatment chemicals for use in the steam system. From approximately 2000 through 2007, Loy-Lange contracted Clayton to provide these services, and in 2008 Loy-Lange switched to another provider, Aquacomp. Clayton and Aquacomp visited Loy-Lange monthly to perform water chemistry testing, adjust Loy-Lange's chemical injection pumps, provide advice to the Loy-Lange stationary engineers, and resupply Loy-Lange with treatment chemicals when required.

In Clayton's feedwater treatment reference manual, which Clayton supplied to Loy-Lange, Clayton emphasizes the importance of frequently monitoring water chemistry to prevent corrosion:

For the prevention of scale and corrosion the proper feedwater conditions must be maintained at all times. While chemical dosages can be proportioned to the make-up flow rate or even to the feedwater flow rate with automatic feed systems; the fact is, these automatic feed systems do not take into account all of the parameters that contribute to variations in oxygen, pH, and hardness levels. Some of these parameters are:

1. Variations in the oxygen content of condensate returned.
2. Fluctuations in the [make-up tank]<sup>a</sup> temperature and the subsequent variation in the efficiency in which oxygen is expelled.
3. High chemical demand on start-up. Extra chemical is required to scavenge the additional oxygen present due to cold water on start-up. Many units are shut down and restarted on a regular basis, sometimes even daily.

And:

Nothing replaces frequent water testing, interpretation of the results, and adjustments in chemical feed rate when necessary. For best results [...]:

---

<sup>a</sup> Loy-Lange and Clayton also called this vessel a "Hotwell."

1. Maintain proper feedwater conditions at all times.
2. Maintain proper off-line and layup<sup>a</sup> conditions at all times.
3. Pay particular attention to the water conditions during start-up and make sure the proper conditions are being maintained.

Clayton's feedwater treatment reference manual recommends at minimum a daily test of water chemistry. According to Loy-Lange employees and Aquacomp, the Loy-Lange stationary engineers performed this testing daily and recorded the results manually in a logbook, which was not recovered from the scene of the explosion.

Loy-Lange also contracted with Clayton to perform quarterly preventive maintenance on the steam system starting in about 2000 and continuing up until the explosion in April of 2017. One of the tasks Clayton performed in those quarterly visits was a water chemistry analysis, separate from the testing conducted during Clayton's monthly visits during the time the company treated Loy-Lange's water. There are 88 records in the data the CSB reviewed from Clayton's and Aquacomp's preventive maintenance logs. An oxygen scavenger deviation below the minimum required level is recorded in 48 of the 88 records. Starting in roughly 2008, when AquaComp overtook Loy-Lange's water treatment business, nearly every measurement (32 of 34 records) recorded shows an insufficiently low concentration of sodium sulfite.

### 1.7.2 Loy-Lange Startup Practices

Loy-Lange started up the steam system every morning and shut it down every night. Below is a description of the Loy-Lange steam system startup practice, based upon interviews<sup>b</sup> the CSB conducted with Loy-Lange employees after the incident.

**Figure 23 - Figure 26** accompany the steam system startup description. In each figure, the primary water flow path is highlighted in bold. Equipment shown in green is on or open. Equipment shown in red is off or closed. Changes in equipment state from the previous diagram are highlighted with red circles or text.

1. To begin the startup procedure, operators closed valves that supplied make-up water and returning condensate to the SCR (valves shown in red in **Figure 23**). Closing these valves prevented any water from entering the SCR. The operators also routed the returning condensate to drains and ensured that the SCR was full of water.
2. Operators started the generator, which was fed water that had been left overnight inside the SCR.
3. Until the generator began producing steam, operators routed the liquid water flowing from the generator coil to a drain.

<sup>a</sup> Loy-Lange used a procedure called "wet layup" to shut down its steam system overnight. In this procedure, the generator coil and SCR are left full of water when the system is shut down.

<sup>b</sup> Of the two employees the CSB interviewed about the startup sequence, according to Loy-Lange, one of them never started the system up and the other spent less than 10% of their time operating the steam generation system. The employee primarily responsible for starting up the Loy-Lange steam system was fatally injured in the incident and thus could not be interviewed. Loy-Lange also provided no specific written startup procedures beyond the Clayton steam generator manual, and told the CSB that any specific written startup procedures for the steam system were destroyed in the explosion.

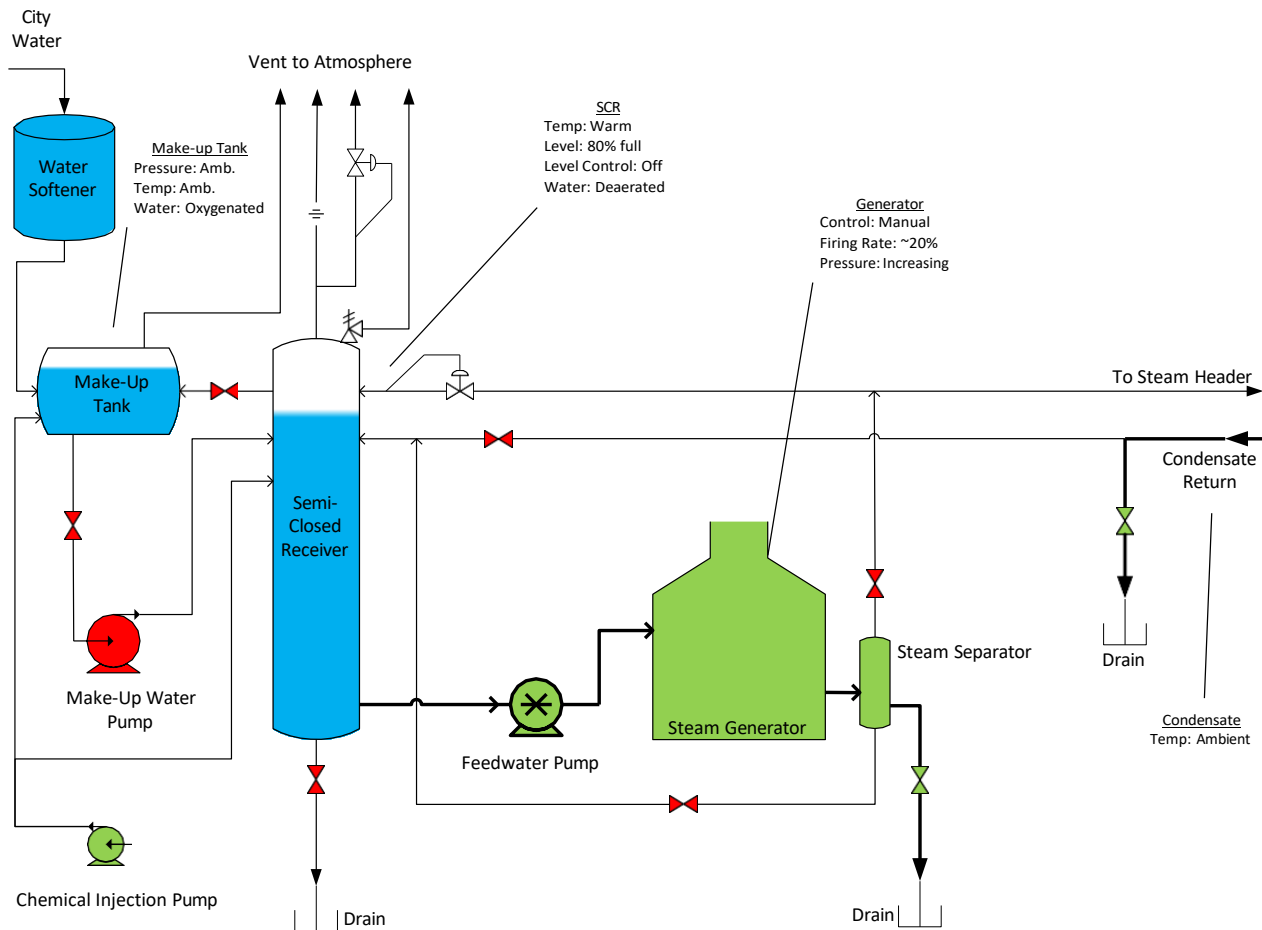

**Figure 23.** Simplified process flow diagram illustrating steam system initial conditions. (Credit: CSB)

4. Once the generator was producing steam, operators slowly opened the valve isolating the steam generator and separator from the process steam header, allowing steam to flow out to the corrugation process equipment.
5. During this time, the liquid level inside the SCR slowly fell from approximately 14 feet to approximately 2 feet,<sup>a</sup> nearly emptying the SCR (**Figure 24**).

<sup>a</sup> Based on CSB calculations.

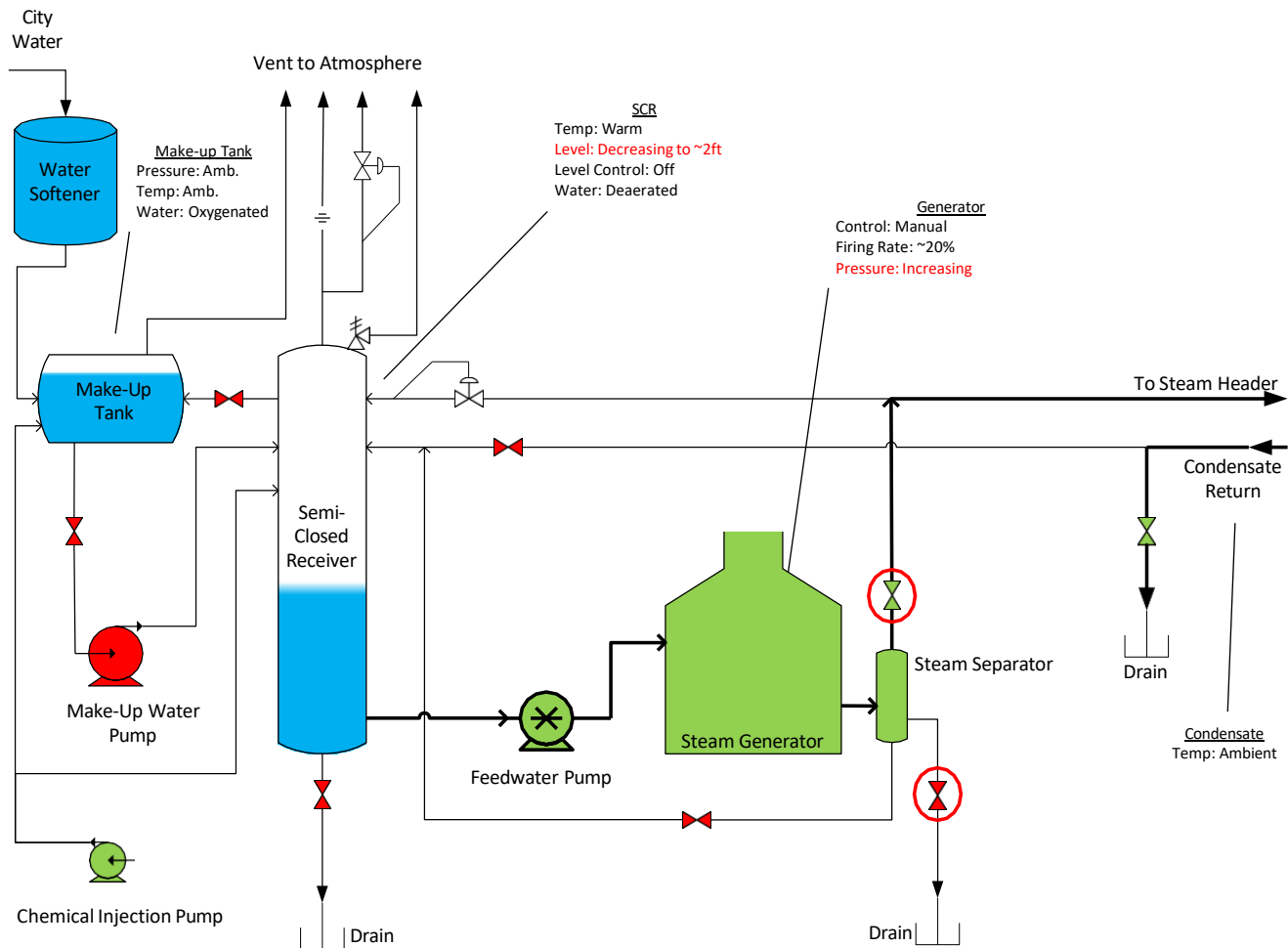

**Figure 24.** Simplified process flow diagram illustrating steam flowing to the steam header. (Credit: CSB)

- Once the SCR was nearly empty, operators placed the SCR level controller in automatic and opened the make-up water supply valve to the SCR. The level controller began calling for make-up water, which turned on the make-up water pump, refilling the SCR with make-up water (**Figure 25**). Because Loy-Lange claimed that its relevant records were destroyed in the explosion, the CSB could not review documentation or data<sup>a</sup> indicating that the make-up tank water was effectively heated by steam and mechanically deaerated—which would occur at temperatures between 190-200°F—before the water was introduced to the SCR. In the event the makeup tank was not heated to the requisite temperature before the water was introduced to the SCR, oxygenated water would be fed to the SCR at this point during the steam system startup operation.

<sup>a</sup> Loy-Lange did not have any process data such as might be recovered from a process data historian or distributed control system (DCS), instead recording a variety of process parameters and metrics manually in a handwritten logbook. The CSB did not recover the logbook from the scene of the incident. According to Loy-Lange, the logbook was stored in the room that was the site of the explosion, and that “any records related to the steam generation system were destroyed in the explosion.”

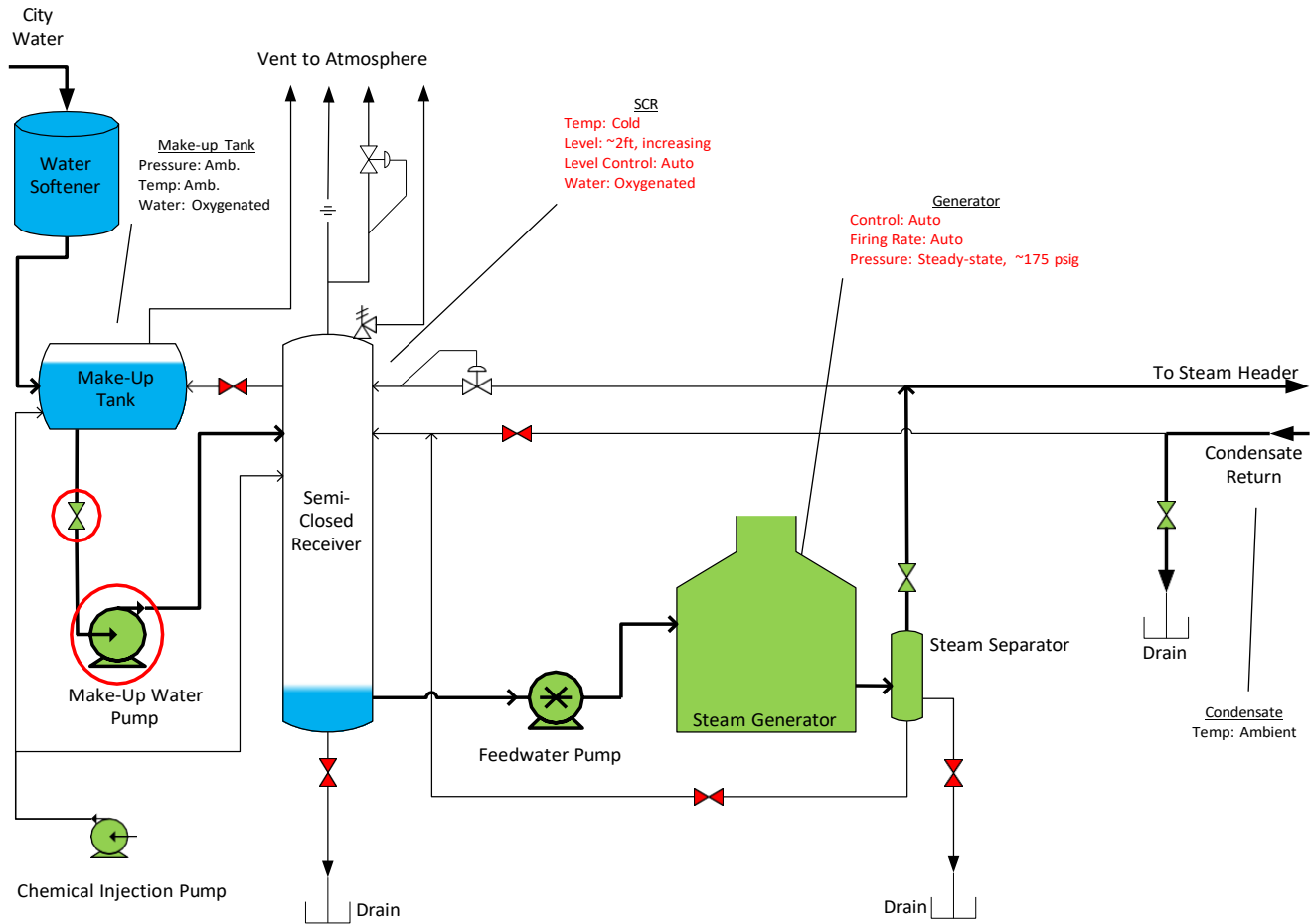

**Figure 25.** Simplified process flow diagram illustrating the introduction of make-up water. (Credit: CSB)

7. Eventually, operators routed the returning condensate back to the SCR instead of to drains (circled valves in **Figure 26**).
8. Unless operators performed a procedure called *blowdown* (see **Figure 27** and Section 1.7.3), a portion of water in the SCR below the outlet nozzle likely was trapped in the bottom head.



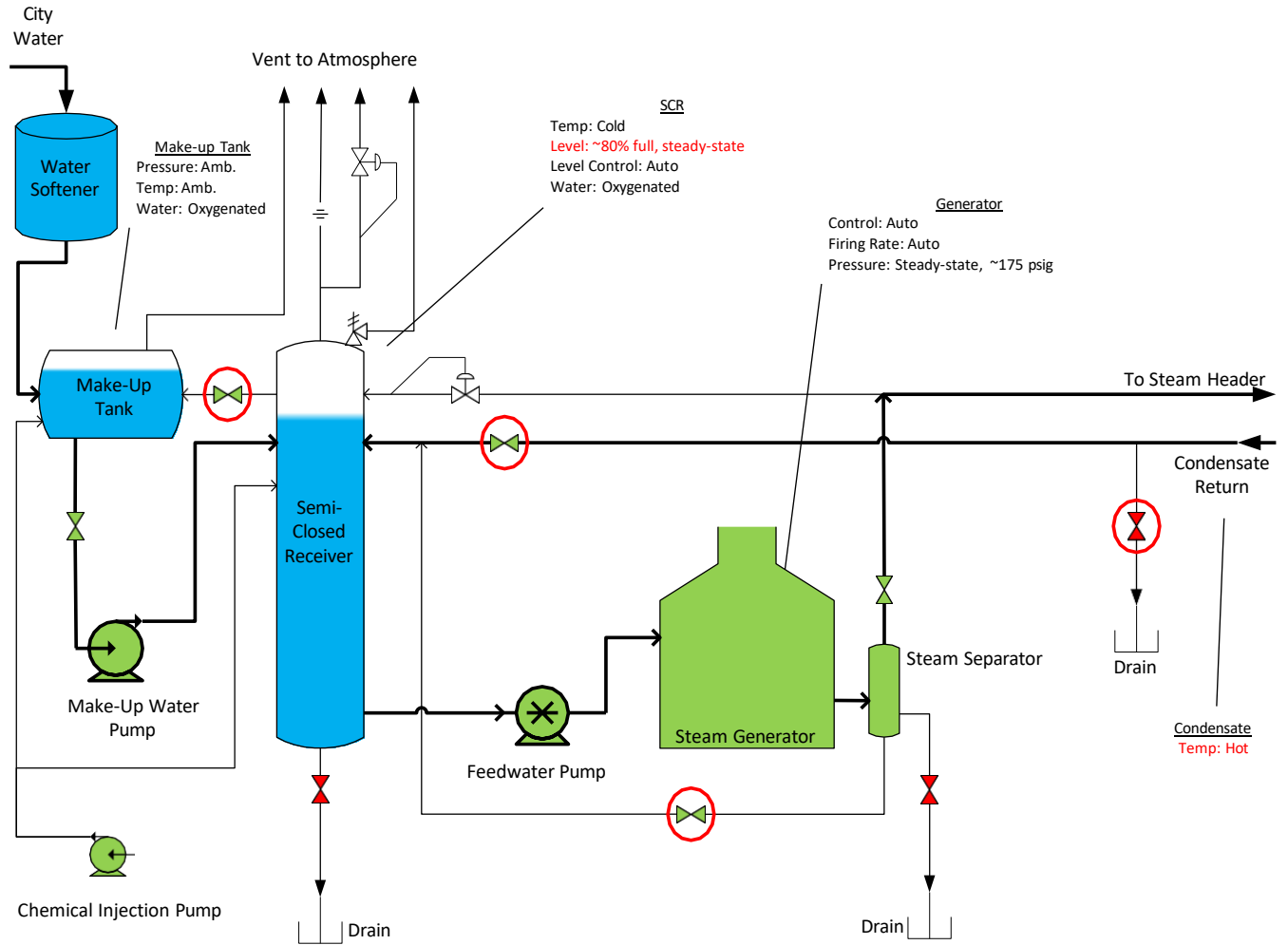
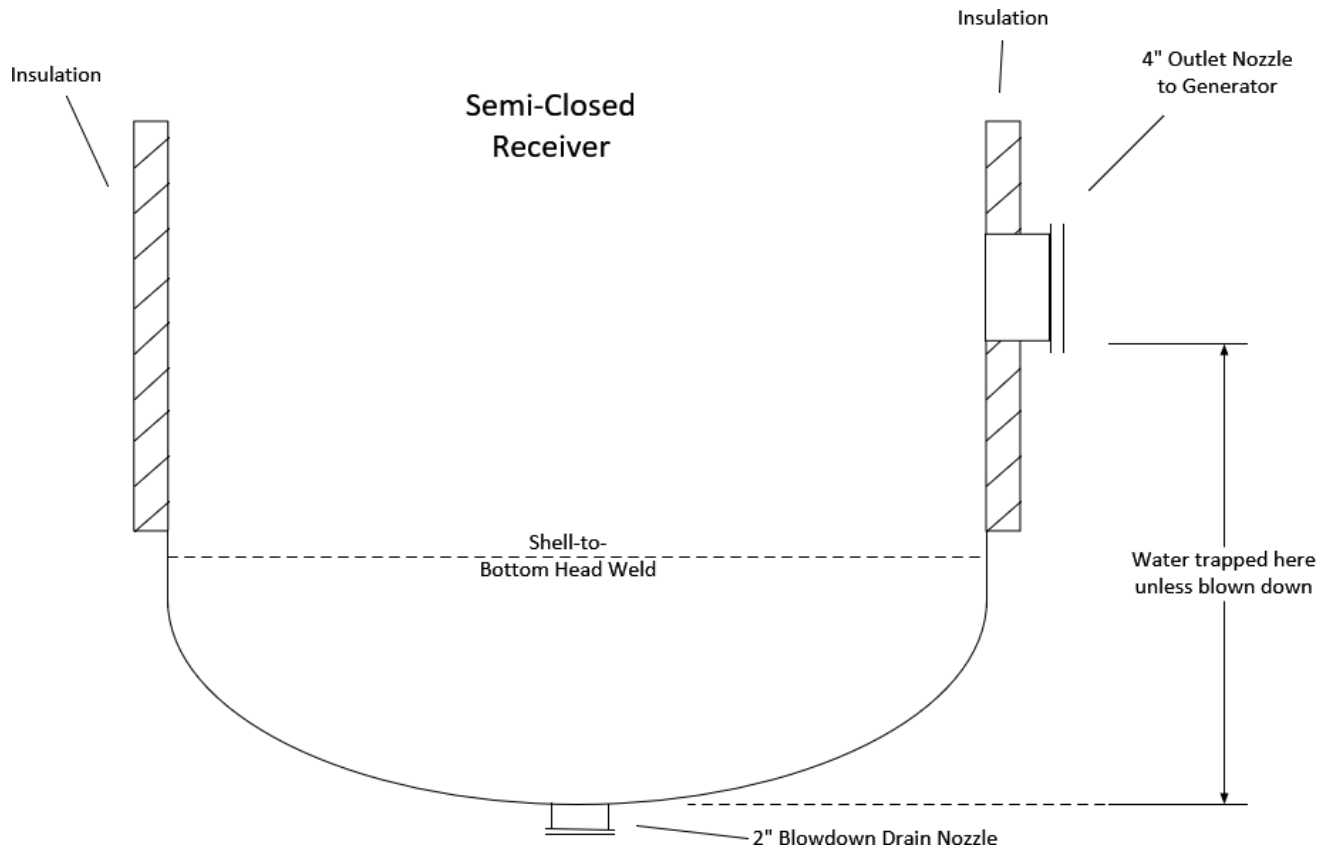

Figure 26. Simplified process flow diagram illustrating steady-state conditions. (Credit: CSB)



**Figure 27.** Conceptual diagram of the SCR bottom head. (Credit: CSB)

### 1.7.3 Loy-Lange Blowdown Practices

Water in the SCR bottom head remained stagnant during normal operation. To achieve flow in the bottom head of the SCR, operators had to manually open the drain line (blowdown) (**Figure 4, Figure 27**). Blowdown was intended by Clayton to drain precipitated solids produced by the water treatment chemicals. Clayton's 1995 operation manual recommended blowdown of the SCR weekly at minimum. In the absence of daily water tests, the manual requires a blowdown frequency of every 10-12 hours. Loy-Lange operators told the CSB that the vessel was rarely and irregularly blown down prior to 2012. In 2012, after the repair to the SCR bottom head (discussed in Section 1.3), they increased the blowdown frequency to weekly.

## 1.8 Process Safety

Events related to process safety at the Loy-Lange facility are described below.<sup>a</sup>

<sup>a</sup> Loy-Lange had a personal safety program, details of which are located in **Appendix C**.

## 1.8.1 Mechanical Integrity

Prior to the incident, Loy-Lange experienced at least three known leaks in the SCR:

- In April 2004, Clayton located an undocumented weld repair made to the SCR, in an undocumented location.
- In August of 2012, the 4-inch outlet nozzle near the bottom head leaked due to corrosion.
- In November of 2012, the SCR bottom head leaked, prompting the repair by Kickham described in Section 1.3 of this report.

In addition to these leaks in the SCR, Loy-Lange experienced corrosion in other parts of the steam system. The CSB found documentation of one known steam separator leak and four generator coil failures.<sup>a</sup> **Figure 28** shows the oxygen pitting corrosion found in two of the four generator coil failures. The images were taken by Clayton after Loy-Lange submitted the failed coils to Clayton for warranty replacement consideration. The left image is of a 2002 coil failure and the right image is of a 2004 coil failure.

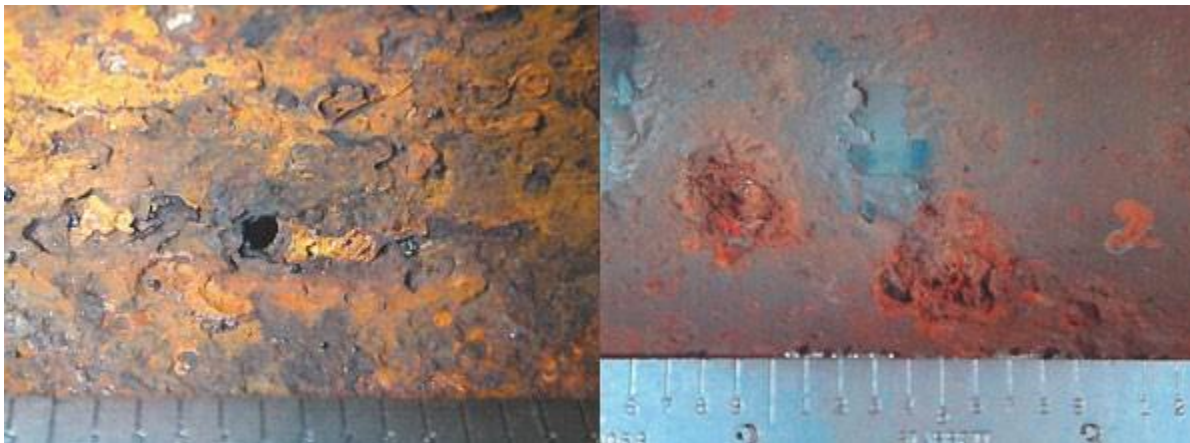

**Figure 28.** Pitting damage in two of Loy-Lange’s steam coils. (Credit: Clayton)

Additionally, employees described an undocumented number of corrosion-induced leaks from the make-up tank. Leaks from the make-up tank were frequent enough that in 2015, Loy-Lange replaced the carbon steel tank with one made of stainless steel. In May 2016, Aquacomp identified oxygen pitting corrosion in the piping between the make-up tank and the SCR. In notes provided to Loy-Lange summarizing the visit, Aquacomp wrote:

The carbon steel piping, removed from the drop leg of the [make-up tank], has oxygen-related pitting. This is obviously due to high dissolved oxygen levels continuously within this area of the [boiler feedwater] system. Further, this is after the [make-up tank], where the mechanical and chemical removal of the

<sup>a</sup> Coil Failures occurred in April 2002, October 2003, March 2004, and December 2016.

dissolved oxygen is to be removed. Based on the oxygen-related pitting observed on the inside [of] the pipe, it is time to re-think why the dissolved oxygen exist[s].

The CSB requested policies and procedures from Loy-Lange relating to mechanical integrity. Loy-Lange did not produce any such policies or procedures, stating that any responsive policies or procedures were destroyed in the explosion.

## 1.8.2 Inspection

### 1.8.2.1 Inspection Recommendations

As early as 2004, Loy-Lange received recommendations from Clayton to perform an inspection of the SCR. In 2004, two Clayton service managers visited Loy-Lange's facility. In an email to the Loy-Lange plant manager summarizing the visit, Clayton wrote:

Have [SCR] Tank inspected by outside company for corrosion and wall thickness

[SCR] Tank has been welded on by a non-certified welder (have weld inspected and certified)

In April of 2004, a Clayton field service technician wrote in his exit report following a Loy-Lange visit:

SCR had a hole in it that was welded. Recommend having SCR inspected for pitting and thickness.

And in December of 2004, Clayton's field service technician again recommended inspection of the SCR:

Because of corrosion, visually inspected inside [steam] separator and noticed excessive corrosion on inner wall of separator. Recommend the semi closed receiver [be] inspected for corrosion by an outside qualified company.

Loy-Lange stated it believed that the stationary engineers were in charge of the steam generation system, and the stationary engineers were to follow the instructions of third parties whom Loy-Lange had contracted for water treatment, maintenance, and repairs in order to safely operate the steam generation system.

### 1.8.2.2 Loy-Lange Inspection Records

The CSB found no evidence indicating that Loy-Lange had a formal inspection program that included internal visual inspection or non-destructive thickness measurement of the SCR separate from repairs.

### 1.8.2.3 Insurance Inspection Records

The CSB requested inspection records from Loy-Lange's insurer, FM Global. FM Global stated that it "did not conduct any boiler and machinery inspections at the [Loy-Lange] facility." FM Global told the CSB that its

rationale for not performing jurisdictional inspections was “The City of St. Louis Municipal Code.”<sup>a</sup> According to FM Global, it did not perform jurisdictional inspections<sup>b</sup> within the City of St. Louis. FM Global identified, in May 2017, several other jurisdictions, like the city of St. Louis, where there were no “pressure vessel codes” including: Montana, South Dakota, New Mexico, Texas, Louisiana, Florida, South Carolina, West Virginia, Connecticut, Michigan, Idaho, and Wyoming. In May 2017, FM Global claimed it inspected pressure vessels in all 50 states within the last five years and employed 186 inspectors certified with NBBI to inspect pressure vessels.

### 1.8.3 Incident Investigation

The CSB requested policies and procedures from Loy-Lange relating to incident investigation. Loy-Lange did not produce any such policies or procedures, stating that responsive policies or procedures were destroyed in the explosion.

### 1.8.4 Hazard Analysis

The CSB requested policies and procedures from Loy-Lange relating to hazard analysis. Loy-Lange did not produce any such policies or procedures, stating that any responsive policies or procedures were destroyed in the explosion.

According to Loy-Lange’s counsel:

No one ever told Loy-Lange that it was unsafe to operate a pressure vessel with a leak. They had done it before in 2004, 2012 and in 2017 on Friday before the explosion.

When the CSB asked the stationary engineers whether they were concerned enough about the SCR leaks to shut the system down, one of them said:

Yes, but not in an emergency shutdown-type situation. We’d had this thing dripping and leaking like crazy before. So was it a concern? Yes, we wanted it repaired. But we weren’t freaking out about it at the time.

And in another interview:

[Leaks in] [h]eaders, any kind of leaks like that coming off of your main equipment is a big deal. You know. And we ... we didn’t take this [leak] lightly either. [...] But it wasn’t an emergency shutdown situation for us because we had dealt through many leaks before that.

---

<sup>a</sup> The Mechanical Code of the City of St. Louis does not contain an explicit prohibition for insurance companies to perform boiler and pressure vessel inspections.

<sup>b</sup> In a response to a CSB information request, FM Global stated that a jurisdictional inspection “is performed to ensure [an] object complies with local regulatory requirements.”

## 1.9 The City of St. Louis and Pressure Vessels

### 1.9.1 City Requirements

The State of Missouri regulates boilers and pressure vessels at the state level. Missouri allows cities and counties to exempt themselves from the state boiler and pressure vessel regulations by issuing local ordinances.<sup>a</sup> At the time of the incident, the City of St. Louis was self-exempted from the state regulations, instead using local ordinances.<sup>b</sup> To regulate boilers and pressure vessels, the City of St. Louis at the time of the incident had adopted the 2009 edition of the International Mechanical Code (IMC) verbatim, except as specifically amended by city ordinance, as “The Mechanical Code of the City of St. Louis [10] [11].”<sup>c</sup> The IMC is authored by the International Code Council (ICC).

At the time of the incident, The Mechanical Code of the City of St. Louis required, among other things:

- the registration of boilers and pressure vessels with the city via application for installation permits;<sup>d</sup>
- that boilers and pressure vessels receive a sticker denoting city inspection and approval prior to being placed in operation;<sup>e</sup>
- application for a repair permit prior to effecting repair to a boiler or pressure vessel;<sup>f</sup>
- operators of certain boilers to obtain Stationary Engineer licensure;<sup>g</sup>
- annual inspection of boilers and pressure vessels by city inspectors;<sup>h</sup>
- repair of boilers and pressure vessels to be performed by either organizations which possess the appropriate ASME Certificate of Authority with extension to field work, or an NBBI “R” Certificate holding company;<sup>i</sup>
- a mandatory hydrostatic test to be performed on the vessel after repair and before being returned to service.<sup>j</sup>

### 1.9.2 City Code Enforcement

At the time of the incident, to enable the enforcement of the Mechanical Code of the City of St. Louis, the Code:

---

<sup>a</sup> Mo. Rev. Stat. § [650.290](#).

<sup>b</sup> Mo. Rev. Stat. § [650.290](#); St. Louis, Missouri, Municipal Code § 68639.

<sup>c</sup> [St. Louis, Missouri, Municipal Code § 68639](#).

<sup>d</sup> St. Louis, Missouri, Municipal Code § 68639-104.2.

<sup>e</sup> St. Louis, Missouri, Municipal Code § 68639-1001.3.

<sup>f</sup> St. Louis, Missouri, Municipal Code § 68639-104.2.

<sup>g</sup> St. Louis, Missouri, Municipal Code § 68639-110.5.1 – 110.5.4.

<sup>h</sup> St. Louis, Missouri, Municipal Code § 68639-1001.2.

<sup>i</sup> St. Louis, Missouri, Municipal Code § 68639-1001.4.

<sup>j</sup> St. Louis, Missouri, Municipal Code § 68639-1001.4.

- prohibited the operation of boilers and pressure vessels without such equipment first being inspected and approved by the City;<sup>a</sup>
- declared it unlawful to “erect, construct, alter, repair, remove, demolish or operate mechanical equipment regulated by this code [...] in conflict with or in violation of any provisions of this code;”<sup>b</sup>
- enabled the City to serve written notice of violation to, prosecute, and penalize persons or corporations responsible for the violation of the Mechanical Code;<sup>c</sup>
- provided for the City to issue “stop work orders” against any “mechanical work [...] done contrary to the provisions of this code or in a dangerous or unsafe manner, or without permit;”<sup>d</sup>
- empowered the City to “seal out of service mechanical equipment [...] covered by the [Code] when, in the code official’s opinion, any of these items are in an unsafe, hazardous, or unsanitary condition, or if the installation was made without obtaining the necessary permit[s].”<sup>e</sup>

The CSB requested information from the City of St. Louis pertaining to the City’s recourse if a City inspector were to discover during the course of their duties an unregistered boiler or pressure vessel. The City’s response stated that:

“A stop work order could be placed on the property. A violation letter could be sent to the property owner, with possible court action taken if ignored. [The Mechanical Code also] grants authority to seal a piece of mechanical equipment out of service if it is deemed dangerous, hazardous, unsanitary, or unapproved.”

### 1.9.3 City Inspection Procedures

The CSB requested from the City of St. Louis all policies and procedures used by the City in the performance and/or documentation of inservice inspection of boilers and pressure vessels within the City’s jurisdiction. The City’s response stated:

“Ordinance 70800 contains the standards referenced in the request. The City does not use inspection checklists, or ‘how to inspect’ type documents.”

### 1.9.4 City Records

Loy-Lange did not register the SCR with the City of St. Louis. The CSB confirmed that the City had no records of any kind for the SCR. The City had no installation permits, repair permits, or inspection records for the SCR, even though these were requirements per The Mechanical Code of the City of St. Louis.

<sup>a</sup> St. Louis, Missouri, Municipal Code § 68639-1001.3.

<sup>b</sup> St. Louis, Missouri, Municipal Code § 68639-108.1.

<sup>c</sup> St. Louis, Missouri, Municipal Code § 68639-108.2 – 108.4.

<sup>d</sup> St. Louis, Missouri, Municipal Code § 68639-108.5.

<sup>e</sup> St. Louis, Missouri, Municipal Code § 68639-104.4.1.

The City did have installation records for the two Loy-Lange steam generators, which indicated that the generators were installed in the 1960s. The City did not have records of the newer generators installed in 1999 and 2001. The City also had records indicating that the City inspected the generators in 1996, 1997, 1998, 1999, 2007 and 2010. The City records did not indicate that City employees inspected the generators annually, as was required by The Mechanical Code of the City of St. Louis.

In 2018, the City of St. Louis adopted a new ordinance that modified some of the inspection requirements discussed above in Section 1.9.1. The updated requirements are discussed in detail in Section 2.2.7.

The CSB requested information from the City of St. Louis regarding the City’s boiler and pressure vessel inspection program. The City responded that as of April of 2022, there were 794 registered boilers and pressure vessels in the City’s records. Of that total, 427 were boilers and the remaining 367 were unfired pressure vessels. The City noted that there may be some redundancies in its count, as the City is in the process of digitizing its records. According to the City of St. Louis, in the time period from July of 2018 to April of 2022, the City had a record of 590 boiler or pressure vessel inspections. The City noted that in April of 2020, inspections were temporarily suspended due to the SARS-CoV-2 (COVID-19) pandemic.

The City indicated that annual boiler and pressure vessel inspections have resumed, but “only when requested by property owners.” The City indicated the rationale for the request-only model as two-fold: ongoing “manpower restrictions and the increased workload of a busy construction industry.” The City also indicated that this “request-only life safety model will be the standard in the next City ordinance cycle.”

### **1.9.5 City Resource Limitations**

City employees told the CSB that the City of St. Louis Building Division, the office in charge of inspecting boilers and pressure vessels, was understaffed and struggled to keep up with the workload, and that most of the inspectors’ time was spent on new construction and HVAC systems. In addition to boilers and pressure vessels, the office was responsible for inspecting all “mechanical equipment” falling under the city’s code, which among other things included commercial and residential HVAC systems, welded piping installations, and carnival and amusement park rides. A city employee told the CSB that the office typically had to “play catch-up” on annual inspections.

Another employee told the CSB that boiler and pressure vessel inspections were assigned lower priority compared with other inspection work, because boilers and pressure vessels were required to be operated by a licensed stationary engineer. The employee described the risk evaluation that the City of St. Louis personnel internally performed to determine how to use their limited resources to perform required inspections. The employee described that in 2009, the City of St. Louis Code was changed to include the installation of residential furnaces as a permitted item. This change was a result of residential furnaces being installed incorrectly, leading to carbon monoxide from the furnace emitting into people’s homes and causing fatalities. The city staff then had to decide whether to prioritize these residential furnace inspections where they had seen fatalities because of improper installation, or to conduct what they considered a “double review” at commercial facilities where stationary engineers were employed. The employee stated:

Do you, you know, review the residential [installations] where people are dying?  
Or do you double review, you know, a commercial situation where you’ve

FDA, Inc.



already got a stationary engineer required by law to be there? [...] It's a question of using your resources. Yes, I would love to have 30 mechanical inspectors and be able to look at every place, every [...] six months.

## 1.10 Description of Surrounding Area

As shown below in **Figure 29**, the Loy-Lange facility was located in an urban area, less than two miles south of downtown St. Louis. As shown in **Figure 12** the Faultless Healthcare Linen Company, where the SCR came to rest, was located roughly 520 (less than one quarter mile) feet from the Loy-Lange facility.

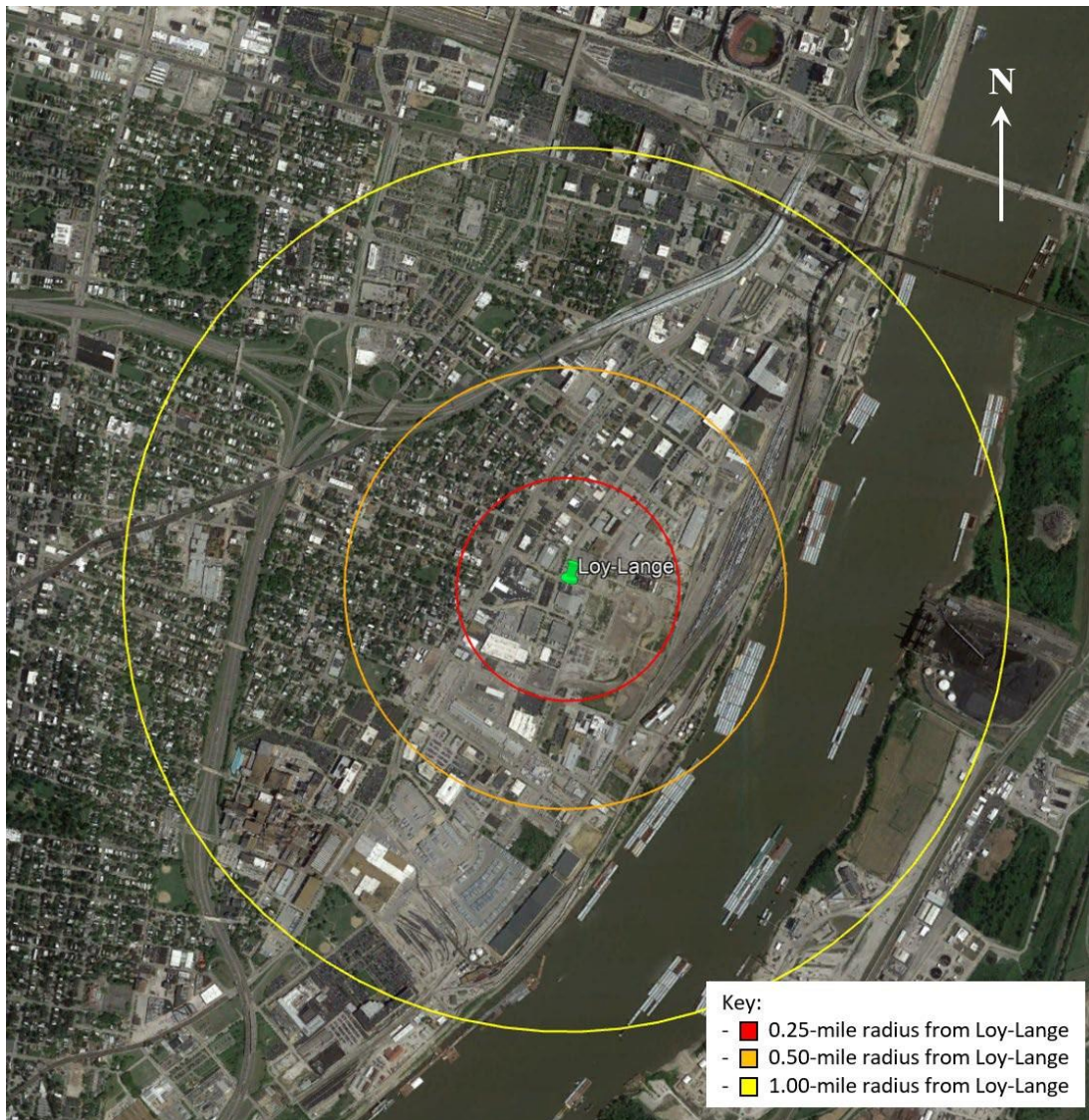

**Figure 29.** Overhead satellite imagery of Loy-Lange's vicinity. Image dated August 2017. (Credit: Google, annotated by CSB)

Summarized demographic data for the approximately one-mile vicinity of the Loy-Lange facility is shown below in **Table 1**. More detailed information, including data sources, can be found in **Appendix D**.

FDA, Inc.

**Table 1.** Summarized Demographic Data of Approximately One-Mile Vicinity of Loy-Lange Facility

Population	Race and Ethnicity	Number of Housing Units	Types of Housing Units	Per Capita Income	% Poverty
51,668	<ul style="list-style-type: none"> <li>• 44.3% White</li> <li>• 47.4% Black</li> <li>• &lt;1% Native</li> <li>• 1.6% Asian</li> <li>• &lt;1% Islander</li> <li>• &lt;1% Other</li> <li>• 1.3% Two+</li> <li>• 3.4% Hispanic</li> </ul>	27,750	<ul style="list-style-type: none"> <li>• Single Unit 40.8%</li> <li>• Multi-Unit 58.2%</li> <li>• Mobile Home &lt;1%</li> <li>• Boat, RV, Van, etc. &lt;1%</li> </ul>	\$36,157	20.4%

### 1.11 Weather at Time of Incident

Data from the St. Louis International Airport Station indicate that at 7:08 a.m. local time on Monday April 3, 2017, conditions were cloudy, the temperature was 59°F, and the wind speed was 8 miles per hour from the east-southeasterly (ESE) direction [12].

### 1.12 Cardboard Corrugation and Pressure Vessels in the United States

The CSB requested from the Fibre Box Association information on the number of cardboard corrugation facilities in the United States. The FBA response stated that there are 394 corrugation facilities in the United States. The FBA did not have records indicating the number of those facilities that operate steam systems. Pressure vessels and steam systems are ubiquitous in the United States. Pressure vessels are used in many U.S. industrial sectors, and apart from their industrial and manufacturing uses, steam systems are used in residential and office buildings, schools, hospitals, and many other locations.

The CSB requested information from NBBI regarding the number of registered pressure vessels in its records. According to NBBI, there were approximately 34.9 million pressure vessels registered with NBBI as of March 31, 2022. Of that total, approximately 8.3 million pressure vessels had been newly registered since January 1, 2017.

As noted in Section 1.9.4, according to the City of St. Louis, as of April 2022 there were 794 registered boilers and pressure vessels in the City's records. Of that total, 427 were boilers and the remaining 367 were unfired pressure vessels. The City noted that there may be some redundancies in its count, as the City is in the process of digitizing its records.

## 2 Incident Analysis

### Introduction

This section discusses the following safety issues the CSB identified in its investigation.

- Pressure Vessel Corrosion
- Pressure Vessel Inspection and Regulation
- Pressure Vessel Repair
- Process Safety Management System

### Exclusionary Findings

The CSB concludes that weather was not a causal factor in the occurrence of this incident.

Observation of a steam plume releasing from a vent on top of the Loy-Lange building suggests there may have been a process upset preceding the incident (discussed in further detail in Appendix B). Loy-Lange did not have any process data such as might be recovered from a process data historian or distributed control system (DCS). In the absence of any reviewable process data, the CSB was unable to determine the operating conditions at the time of the incident. In addition, the SCR was found to be equipped with a pressure relief valve with a set pressure greater than the vessel's Maximum Allowable Working Pressure (MAWP). Equipping a pressure vessel with a relief valve set at a higher pressure than its MAWP does not adhere to ASME or NBIC requirements.<sup>a,b</sup> The CSB concludes that while there was a large steam plume releasing from the Loy Lange building before the incident and the SCR was equipped with a pressure relief valve with a set pressure greater than the vessel's Maximum Allowable Working Pressure (MAWP), there was insufficient evidence to determine if there was an overpressure event in the SCR at the time of the SCR failure.

### 2.1 Pressure Vessel Corrosion

#### 2.1.1 SCR Metallurgical Examination Findings

Visual examination and thickness measurements conducted during post-incident metallurgical examination of the SCR confirmed the presence of extensive pitting corrosion and generalized corrosion. **Figure 30** below shows pitting corrosion damage found in the SCR bottom head post-incident.

---

<sup>a</sup> ASME BPVC Section VIII Div. 1, 2021 ed. [38], states in section UG-155(a) that "the set pressure marked on the [relief] device shall not exceed the [MAWP] of the vessel."

<sup>b</sup> NBIC Part 1 – *Installation*, 2021 ed. [39], states in section 4.5.5.a that "when a single pressure relief device is used, the set pressure marked on the device shall not exceed the [MAWP]."



**Figure 30.** Pitting corrosion damage in SCR bottom head. (Credit: CSB)

Nondestructive and destructive thickness measurement showed that corrosion primarily occurred in the SCR bottom head and was minimal elsewhere in the vessel (Section 1.6). **Figure 31** below shows a summary of some of the thickness findings:

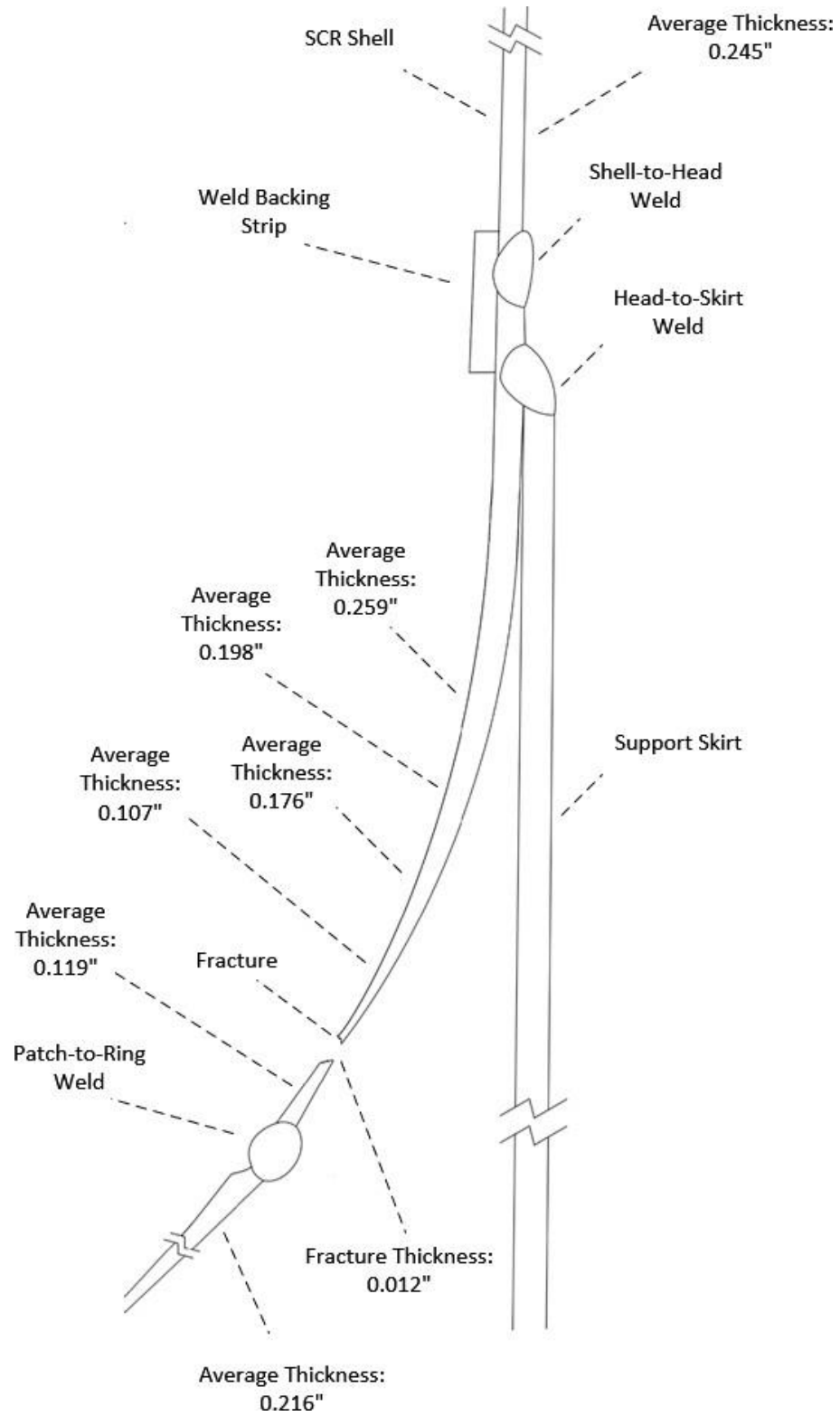

**Figure 31.** Conceptual cross-sectional diagram of the SCR bottom head, showing examination findings. (Credit: CSB)

FDA, Inc.

The minimum thickness of the SCR bottom head, specified on the vessel's U1A form, was 0.2204 inches. As shown above in **Figure 31**, the average thickness of nearly the entire SCR bottom head was thinner than the required thickness after the incident. The thinnest spot measured on the fracture surface, likely the fracture initiation point, was measured at 0.012 inches, and the average thickness near the patch to ring weld was roughly half the minimum required thickness.

The CSB concludes that:

- The Loy-Lange SCR ruptured due to extensive oxygen corrosion that reduced its wall thickness, which prevented the SCR from containing its operating pressure.
- Had Loy-Lange effectively prevented corrosion in its steam system, the SCR likely would not have failed due to excessive thinning.

## 2.1.2 BLEVE

A BLEVE requires three components:

- 1) a liquid that exists above its normal atmospheric pressure boiling point;
- 2) containment that causes the pressure on the liquid to be sufficiently high to suppress boiling; and,
- 3) a sudden loss of containment to rapidly drop the pressure on the liquid [9, p. 311].

The SCR typically contained water held at around 100 psig and 330°F (Section 1.1.4). Therefore, the water in the SCR was contained at a temperature greater than its atmospheric boiling point and at a pressure sufficiently high to suppress boiling. The failure occurred along the entire circumference of the re-used ring of steel left in place during Kickham's 2012 SCR repair (Section 1.6) and resulted in a sudden loss of containment. The abrupt circumferential failure of the bottom head resulted in the exposure of the pressurized water inside the SCR to atmospheric pressure, which resulted in sudden boiling. Therefore, the catastrophic failure of the SCR meets the definition of a BLEVE. The CSB concludes that the catastrophic circumferential failure of the SCR bottom head resulted in a rapid pressure reduction upon the water inside the vessel, which resulted in a boiling liquid expanding vapor explosion, or BLEVE.

## 2.1.3 Presence of Dissolved Oxygen

The oxygen pitting corrosion observed in the SCR bottom head was the result of dissolved oxygen remaining present in the steam system water. It is evident that Loy-Lange's mechanical and chemical deaeration practices were insufficient and failed to prevent the presence of dissolved oxygen in its steam system water.

Discussed below, Loy-Lange's steam system water routinely lacked sufficient oxygen scavenger to properly chemically deaerate the water, and Loy-Lange's startup practices likely introduced dissolved oxygen into the steam system water daily.

### 2.1.3.1 Inadequate Water Treatment

The Clayton operation manual for the Loy-Lange steam system recommended daily testing of water chemistry and adjustment of water treatment chemical dosing based on those testing results. Loy-Lange and its contractors conducted the following water chemistry testing routines (Section 1.7.1):

- According to Loy-Lange employees and Aquacomp, Loy-Lange stationary engineers tested the water chemistry daily and recorded results manually in a handwritten logbook.
- Clayton, and later Aquacomp, visited Loy-Lange monthly to resupply Loy-Lange with treatment chemicals, review the Loy-Lange operators' water testing results, and make or recommend changes to the water treatment chemical dosing.
- Clayton performed quarterly preventive maintenance visits, which among other tasks included a water chemistry analysis.

The Loy-Lange handwritten logbook was not recovered from the scene of the incident. Thus, the CSB could not review Loy-Lange's daily water testing data, and Loy-Lange had no other process data, such as might be obtained from a DCS. The CSB did review data from Clayton's and Aquacomp's water testing records, which in total comprised 88 records of Loy-Lange's water chemistry. A deviation below the minimum required oxygen scavenger concentration was recorded in 48 of the 88 records (Section 1.7.1). It is important to note that these records only show instantaneous measurements of Loy-Lange's water chemistry over a period of roughly 17 years. However, the records, along with the routine occurrence of corrosion and leaks in the steam system (Section 1.8.1) show that Loy-Lange regularly had insufficiently deaerated water in its steam system.

Clayton's feedwater treatment manual required Loy-Lange to introduce "extra chemical [...] to scavenge the additional oxygen present due to cold water" during startup (Section 1.7.1). Because the Loy-Lange handwritten logbook was not recovered from the scene of the incident, there was insufficient evidence to determine whether Loy-Lange followed this startup requirement.

Although Loy-Lange employed contractors to manage its water treatment program, the contractors did not continuously monitor the program. The Clayton operation manuals outline the importance of daily water chemistry testing and adjustments to chemical dosing based on the testing results. Thus, Loy-Lange also had responsibility for maintaining properly treated steam system water.

The CSB concludes that Loy-Lange and its contractors did not effectively monitor, remove, or treat the dissolved oxygen in the steam generation system's water.

### 2.1.3.2 Presence of Oxygenated Water from Startup

The most likely routes of oxygen intrusion into the Loy-Lange steam system were the naturally occurring dissolved oxygen in the city water supply and the make-up tank's atmospheric vent line. Given that the solubility of oxygen in water increases as water temperature decreases, the water in the make-up tank and SCR would have been able to re-absorb oxygen from the atmosphere as it cooled prior to system startup the following morning. The SCR had an atmospheric vent line as well, although its vent line was installed with a ¼-inch orifice plate (Sections 1.1.2 and 1.1.4).

Described in Section 1.7.2, Loy-Lange nearly emptied the SCR each day during startup. When the SCR was nearly empty, operators fed water from the make-up tank into the SCR. Loy Lange did not have process data indicating that the make-up tank water was effectively heated by steam and mechanically deaerated—which would occur at temperatures between 190-200°F—before the water was introduced to the SCR. In the event the makeup tank was not heated to the requisite temperature before the water was introduced to the SCR, oxygenated water would be fed to the SCR during the steam system startup operation. To combat the risk of increased oxygen load during startup, the Clayton operation manuals required Loy-Lange to use extra oxygen scavenger when starting up the system. But, as described in Section 2.1.3.1, there was insufficient evidence to determine whether Loy-Lange followed this requirement. However, the observed oxygen pitting corrosion in the SCR bottom head confirms the chronic presence of dissolved oxygen in that region of the SCR.

This oxygen, likely introduced into the SCR during daily startup operations, was the result of either insufficient mechanical deaeration, chemical deaeration, or both. Because the SCR bottom head trapped water below the SCR outlet nozzle (illustrated by **Figure 32**), some oxygenated water from startup would remain trapped at the bottom of the vessel until operators performed the weekly blowdown. Although blowdown was not expressly intended by Clayton to remove dissolved oxygen from the system (Section 1.7.3), given that oxygenated water likely remained trapped in the SCR bottom head, it is likely that blowing down the SCR daily after startup would have drained oxygenated water from the bottom head and filled it with treated water. The CSB concludes that Loy-Lange likely introduced oxygen into the SCR during its daily startup operation.

Loy-Lange no longer operates its steam system. Therefore, the CSB issues no recommendations to Loy-Lange to correct its steam system operation practices.



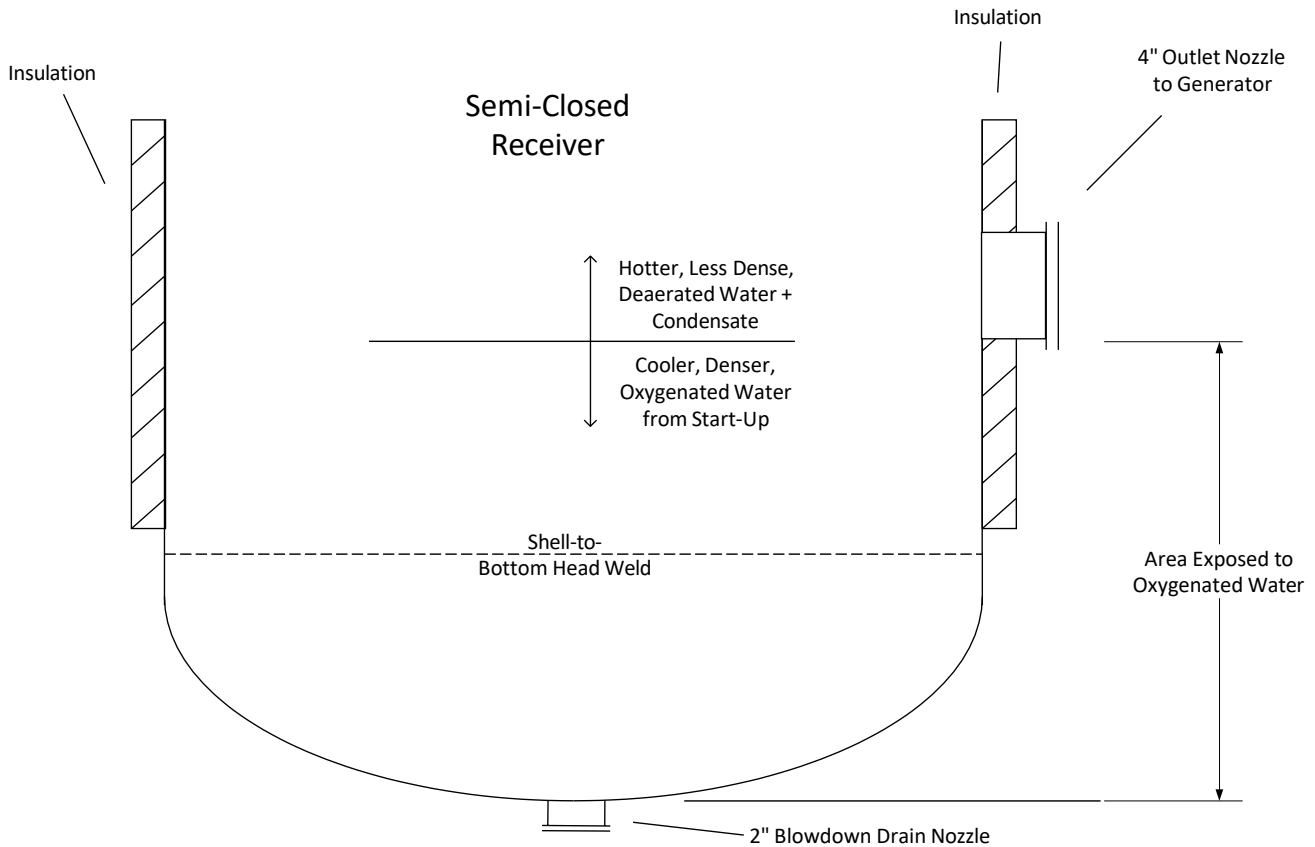

**Figure 32.** Conceptual diagram of the SCR bottom head. (Credit: CSB)

## 2.2 Pressure Vessel Inspection and Regulation

Regulations and industry standards provide requirements and guidance on the inspection of boilers, pressure vessels and other pressure-retaining equipment. In this section, relevant industry guidance applicable to pressure vessels, and regulations applicable to Loy-Lange, are discussed.

### 2.2.1 Pressure Vessel Inspection Requirements and Guidance

To ensure pressure vessels like Loy Lange's SCR are safe to operate, OSHA, the National Board of Boiler and Pressure Vessel Inspectors (NBBI), and the American Petroleum Institute (API) have published codes and guidance on methods to inspect pressure vessels, described below.

#### 2.2.1.1 OSHA Guidance

In 1989, OSHA released Instruction Publication 8-1.5: *Guidelines for Pressure Vessel Safety Assessment* [13].<sup>a</sup> It contains analysis, references, and guidance on many aspects of pressure vessels, including design, failure

<sup>a</sup> According to OSHA, Publication 8-1.5 is not a standard, regulation or substantive rule but is instead intended to provide guidance for the assessment of pressure vessel safety. [41]

modes, inspection methods, and inspection frequencies. Regarding inspection and repair, OSHA references two organizations—NBBI and API—which have published extensive guidance on the inspection and repair of pressure vessels:

[NBIC] and API 510 – These two [standards] are discussed together since the inservice inspection requirements of the two are similar [...]. Both documents are for general application and both cover rerating, alteration, and repair in addition to inservice inspection requirements. API 510 is intended for pressure vessels used in the refinery and petrochemical industries and NBIC is for all other applications [13, p. A52].

API 510 and NBIC are both widely adopted and often cited as Recognized and Generally Accepted Good Engineering Practice (RAGAGEP) by regulators, jurisdictional authorities, and companies in many industrial sectors.

### 2.2.1.2 The National Board of Boiler and Pressure Vessel Inspectors (NBBI)

Created in 1919, the NBBI “promote[s] greater safety to life and property through uniformity in the construction, installation, repair, maintenance, and inspection of pressure equipment.” Its stated functions include the following:

- Training of inspectors and other industry professionals;
- Development of the National Board Inspection Code (NBIC);
- Retention of records of pressure-retaining items registered with the NBBI;
- Commissioning of inspectors as Repair (R) and Inservice (IS) inspectors; and,
- Accreditation of repair and alteration organizations [14].

Regulatory adoption of the NBIC is widespread throughout the United States, including in Missouri [15]. The NBIC contains guidance on inspection, maintenance, and repair of boilers, pressure vessels, piping, and pressure relief devices.

According to NBBI:

The *National Board Inspection Code* (NBIC) was first published in 1946 as a guide for chief inspectors. It has become an internationally recognized standard, adopted by most US and Canadian jurisdictions. The NBIC provides standards for the installation, inspection, and repair and/or alteration of boilers, pressure vessels, and pressure relief devices.

The NBIC is organized into four (4) Parts to coincide with specific post-construction activities involving pressure-retaining items. [...] The NBIC is

FDA, Inc.

developed and maintained by a consensus committee, the NBIC Main Committee, composed of industry experts.

The NBIC Main Committee updates the NBIC every other year. The updates are presented on the National Board's website for public review in August of the year prior to the Edition date [16].

### 2.2.1.3 NBIC Part 2 Requirements

NBIC Part 2 *Inspection* describes the inservice inspection of pressure vessels and other pressure-retaining components. Section 4.4 of NBIC Part 2 details acceptable methods for assessing the condition of pressure vessels, as follows:

This section provides guidelines and alternative methods to assess materials and pressure-retaining items subject to degradation or containing flaws identified during inservice inspections or examinations. [...] If the pressure-retaining item is to remain safe in operation, the service conditions and the length of time before the next inspection must be identified. There are various methods that can be used to assess the condition of a pressure-retaining item to establish remaining service life and to ultimately determine the inspection interval. In some cases, a visual inspection of the pressure-retaining item will suffice. However, more comprehensive condition assessment methods may be required, including an engineering evaluation performed by a competent technical source [17, p. 65].<sup>a</sup>

NBIC places the responsibility for the inspection program on the owner/user:

Safe and adequate implementation of Fitness for Service Assessment (FFSA) programs is the responsibility of the owner or user. Responsibility includes verifying and understanding jurisdictional rules/regulations and inservice inspection requirements.<sup>b</sup>

The owner or user of the pressure-retaining item is responsible for the selection and application of a suitable fitness for service or condition assessment methodology described in this section, subject to review and approval by the Jurisdiction, if required [17, p. 65].<sup>c</sup>

For pressure vessels like the Loy-Lange SCR, NBIC Part 2 recommends that damage mechanisms such as corrosion be evaluated, and that inspection intervals be adjusted based on evaluation results.<sup>d</sup> NBIC Part 2 requires the following maximum inspection intervals:

---

<sup>a</sup> NBIC Part 2 (2021), Paragraph 4.4.1.a.

<sup>b</sup> NBIC Part 2 (2021), Paragraph 4.4.1.c.

<sup>c</sup> NBIC Part 2 (2021), Paragraph 4.4.3.a.

<sup>d</sup> NBIC Part 2 (2021), Paragraph 4.4.6.

- External Inspection at one quarter of the vessel’s estimated remaining service life, or five years, whichever is shorter.<sup>a</sup>
- Internal Inspection at one half of the vessel’s estimated remaining service life, or ten years, whichever is shorter.<sup>b</sup>

Regarding inspection results, NBIC Part 2 states:

If inspection and engineering assessment results indicate that a pressure-retaining item is safe for continued operation, future monitoring and inspection intervals should be determined and submitted to the Jurisdiction for review and approval. If an engineering assessment indicates that a pressure-retaining item is not suitable for service under current operating conditions, new operating conditions should be established (i.e., de-rate), or the item could be repaired subject to revised inspection intervals, or the item could be replaced.<sup>c</sup>

## 2.2.2 Regulatory Jurisdiction

The State of Missouri regulates boilers and pressure vessels.<sup>d</sup> Missouri adopts Part 1 *Installation*, Part 2 *Inspection*, and Part 3 *Repair and Alterations* of NBIC with Parts 1 and 3 being mandatory and Part 2 being permissive.<sup>e</sup> Missouri’s statute requires the external inspection of pressure vessels every two years, but does not mandate internal inspections:

Pressure vessels shall receive a certificate inspection every two (2) years. This inspection shall be an external inspection. The inspector may mandate an internal inspection if the inspector feels it is necessary [18].<sup>f</sup>

However, Missouri’s statute exempts cities or counties from the state regulation, if they regulate boilers and pressure vessels by local ordinance:

The provisions of [the Missouri Boiler and Pressure Vessel Act] shall not apply in cities or chartered counties which regulate boilers and/or pressure vessels by ordinance [19].<sup>g</sup>

As of the 2017 explosion at Loy-Lange, and as of the issuance of this report, the City of St. Louis was self-exempted from the state code by virtue of having its own ordinance. Thus, Missouri’s requirements did not

<sup>a</sup> NBIC Part 2 (2021), Paragraph 4.4.7.2.f.

<sup>b</sup> NBIC Part 2 (2021), Paragraph 4.4.7.a.

<sup>c</sup> NBIC Part 2 (2021), Paragraph 4.4.4.b.

<sup>d</sup> The State of Missouri Boiler and Pressure Vessel rule can be found here: <https://s1.sos.mo.gov/cmsimages/adrules/csr/current/11csr/11c40-2.pdf>.

<sup>e</sup> Mo. Code Regs. [Tit.11 § 40-2.015\(2\)\(A\)](#).

<sup>f</sup> Mo. Code Regs. [Tit.11 § 40-2.022\(5\)\(A\)](#).

<sup>g</sup> Mo. Rev. Stat. § [650.290](#).

apply to Loy-Lange,<sup>a</sup> and the City of St. Louis was the jurisdictional authority responsible for boilers and pressure vessels in the city.

As discussed above in Section 1.9.1, at the time of the 2017 Loy-Lange explosion, the City of St. Louis adopted the 2009 edition of the IMC [10], as amended by ordinance 68639 [11],<sup>b</sup> as *The Mechanical Code of the City of St. Louis* (“City of St. Louis Code”). The City of St. Louis Code contained several requirements relevant to the 2017 explosion at Loy-Lange, discussed below.

### 2.2.3 Absence of SCR Installation and Repair Permits

In 1997, at the time of the installation of the Loy-Lange SCR, the City of St. Louis Code required companies to apply for an installation permit prior to installing a pressure vessel. The City of St. Louis required that the permit be applied for by:

- The owner or lessee of a structure; or
- The agent of either; or
- The registered design professional employed in connection with the proposed work; or
- The contractor employed in connection with the proposed work.<sup>c</sup>

It was therefore Loy-Lange’s or its contractors’ responsibility to apply for and obtain an installation permit for the SCR. The CSB found no evidence of an installation permit for the SCR. The City of St. Louis produced no record of a permit either applied for by any party or granted by the city for the installation of the SCR (Section 1.9.2). Thus, Loy-Lange and its contractors did not ensure that the vessel was registered with the City of St. Louis as required by the City of St. Louis Code.

Furthermore, the City of St. Louis prohibited the operation of boilers and pressure vessels that had not been inspected and approved by the City of St. Louis upon installation (Section 1.9.1).<sup>d</sup> The CSB found no evidence of such an inspection. Thus, Loy-Lange operated an unregistered pressure vessel.

In 2012, at the time of Kickham’s SCR repair, the City of St. Louis also required permitting for the repair of pressure vessels.<sup>e</sup> The responsibility for application for the permit was the same as the 1997 requirements for installation permits shown above.<sup>f</sup> The CSB found no evidence that either Loy-Lange or Kickham applied for a repair permit for the SCR. The City of St. Louis produced no record of a permit either applied for by any party

<sup>a</sup> Loy-Lange was also not subject to either the U.S. Occupational Safety and Health Administration (OSHA) Process Safety Management standard or the Environmental Protection Agency (EPA) Risk Management Plan (RMP) rule.

<sup>b</sup> City of St. Louis Ordinance number 68639 can be found here:

<https://www.stlouis-mo.gov/government/city-laws/upload/legislative//Ordinances/BOAPdf/68639x00.pdf>.

<sup>c</sup> St. Louis, Missouri, Municipal Code § 63806-106.3.

<sup>d</sup> St. Louis, Missouri, Municipal Code § 68639-1001.3.

<sup>e</sup> St. Louis, Missouri, Municipal Code § 68639-1001.4.

<sup>f</sup> St. Louis, Missouri, Municipal Code § 68639-106.3.

or granted by the city for the repair of the SCR (Section 1.9.2). Thus, Kickham and Loy-Lange performed an unpermitted repair to the SCR in 2012.

Ultimate responsibility for ensuring the safety of its operation and for complying with all regulatory requirements rests with the owning/operating entity. Loy-Lange failed to ensure that the SCR was properly permitted with the City of St. Louis, thereby compromising safety and not complying with regulatory requirements. The CSB concludes that Loy-Lange did not ensure that the SCR was appropriately permitted as required by the City of St. Louis.

To ensure that any further regulatory compliance deficiencies are uncovered and addressed, Loy-Lange should engage a qualified third-party to conduct a comprehensive review or audit of Loy-Lange's regulatory compliance practices and current compliance status.

## 2.2.4 City of St. Louis Inspection Requirements

For inspection of mechanical equipment in general, the City of St. Louis Code contained requirements for the inspection of mechanical equipment upon installation.<sup>a</sup> After installation, it is critical that equipment is inspected at regular intervals to ensure equipment remains safe to operate. However, City of St. Louis Code did not adopt NBIC Part 2 *Inspection*, which describes the inservice inspection of pressure vessels and other pressure-retaining components. In addition, the 2009 IMC, which the City of St. Louis had adopted, contained no requirements for inservice inspection of boilers and pressure vessels. The only requirement for periodic inspection was added by the city to its Code, via amendment, as follows:

All boilers, steam generators and pressure vessels subject to the provisions of this code shall be inspected annually by the code official or representative. The inspection shall be as thorough as circumstances permit.<sup>b</sup>

Thus, the City of St. Louis Building Division was responsible for annually inspecting boilers and pressure vessels in the city. Only the annual frequency was specified in the code. Specific inspection tasks and methods were not specified in the regulation. As described above, there was no adopted standard, such as NBIC Part 2 *Inspection* or API 510 *Pressure Vessel Inspection Code*, to which city inspectors were required to inspect.

## 2.2.5 Absence of SCR Mechanical Integrity Program

The CSB requested copies of Loy-Lange's policies relating to mechanical integrity, and Loy-Lange did not produce responsive documents (Section 1.8.1). According to Loy-Lange, any responsive policies were destroyed in the explosion. According to CCPS, a mechanical integrity program is “[a] program to ensure that process equipment and systems are and remain mechanically suitable for operation. It involves inspection, testing, upgrading and repairs of equipment, as well as written procedures to maintain on-going integrity of equipment [20].” A robust mechanical integrity program should have an inspection component that addresses damage mechanisms and ensures operability of the equipment.

<sup>a</sup> St. Louis, Missouri, Municipal Code § 68639-107.

<sup>b</sup> St. Louis, Missouri, Municipal Code § 68639-1001.2.

As required by the City of St. Louis, Loy-Lange's steam generation system was operated by stationary engineers.<sup>a</sup> Loy-Lange stated it believed that the stationary engineers were in charge of the system, and the stationary engineers were to follow the instructions of third parties whom Loy-Lange had contracted for water treatment, maintenance, and repairs in order to safely operate the steam generation system. The CSB found no evidence that Loy-Lange developed a robust mechanical integrity program with an inspection program that monitored corrosion in the steam generation unit.

In the absence of its own mechanical integrity program, Loy-Lange asserted it relied upon Clayton, who performed quarterly preventive maintenance on the steam system. In 2004, 13 years before the 2017 explosion, Loy-Lange received at least three separate recommendations from Clayton to have the SCR inspected for corrosion and pitting (Section 1.8.2.1). Even though Loy-Lange claimed it relied upon Clayton, the CSB found no evidence that Loy-Lange acted upon Clayton's recommendations to inspect the SCR internally for corrosion.

Additionally, in 2012, the SCR experienced corrosion to the point that water leaked through the vessel's wall. After repairing the leaking SCR, Loy-Lange did not conduct an incident investigation to determine the cause(s) of the failure. Kickham when it provided its quote for further alterations of the SCR (Section 1.3) communicated that there was corrosion in the vessel. Loy-Lange, at this point, was aware that corrosion was occurring in the vessel but had not determined the mechanism by which it was corroding. The vessel was not designed for corrosive service. As seen in the metallurgical analysis (Section 1.6), the shell and top head of the SCR were relatively unaffected by corrosion. According to CCPS's *Guidelines for Risk Based Process Safety*, catastrophic events may have complex causes and focusing on process safety helps avoid overly simple solutions. For example, when there is corrosion, simply replacing the equipment may not be sufficient. A process safety focus would require the facility to answer questions like:

- is the corrosion rate excessive and if so, why?
- is there a process conditions issue that needs to be addressed?
- is the inspection frequency appropriate [21, p. 48]?

Consequently, an incident investigation followed by corrective actions could have included establishing an inspection program that monitored the SCR to ensure that other corrective actions are working and verifying that the corrosion rate is in line with expectations.

Furthermore, in May 2016, almost a year before the incident, Aquacomp found corrosion in the piping between the makeup water tank and the SCR. According to CCPS's *Practical Approach to Hazard Identification for Operations and Maintenance Workers*, "corrosion may also exist inside process equipment where it is in direct contact with process fluids [...]; this corrosion cannot be easily detected without the use of specialized methods and equipment. Where internal corrosion is suspected, equipment should be thoroughly inspected at the next planned maintenance outage. Severe corrosion can lead to loss of containment resulting in a significant fire and explosion [22, p. 135]." This corrosion prompted AquaComp to question why the dissolved oxygen, the cause of corrosion, was present (Section 1.8.1). Again, Loy-Lange did not conduct an incident investigation. AquaComp recommended a change in water chemistry at the time it discovered corrosion in the piping between the make-up tank and the SCR. As discussed earlier, a robust mechanical integrity program should have prompted an incident

---

<sup>a</sup> St. Louis, Missouri, Municipal Code § 68639-110.5.1 – 110.5.4.

investigation into the cause of the damage mechanism, prompted a change in the inspection program, or evaluation of the process or the vessel and its design.

Most importantly, on the day of the incident, the SCR was leaking before startup. A robust mechanical integrity program should have identified a leaking pressure vessel as a safety issue that should have prevented a startup. Following the identification of a leak, a vessel should be removed from service, and it should be thoroughly inspected and evaluated as discussed earlier. Had Loy-Lange taken the SCR out of service when it identified the leak and kept it out of service until it was inspected, evaluated, and repaired, the incident could have been prevented.

An inspection program can have many components including inspection intervals, types of inspection, and methods of inspection. Although not required, NBIC Part 2, as discussed in Section 2.2.1.3, provides guidance to companies on inspections. For example, a vessel that is susceptible to a damage mechanism, like corrosion, is supposed to be assessed, and based on that evaluation, an inspection frequency should be established. Additionally, NBIC requires periodic external and internal inspection. Although it does not require a particular method for an internal inspection, it discusses methodologies like the use of a borescope to visually inspect. As noted earlier, damage mechanisms like the corrosion in the SCR cannot be determined simply from an external visual inspection until it is too late, and the vessel's integrity is compromised. A robust inspection program could have identified the limitations associated with an external inspection and required an inspection methodology that could have identified the corrosion, such as the use of internal borescopic visual inspection or the use of ultrasonic thickness measurement.

The CSB concludes that:

- Loy-Lange did not have a robust mechanical integrity program that ensured the SCR was operating safely as intended and designed.
- Loy-Lange never conducted an incident investigation when corrosion was found in the steam generation system.
- Loy-Lange could have prevented the 2017 incident if it had conducted an effective incident investigation after the 2004 or 2012 SCR corrosion failures and implemented corrective actions including establishing an inspection program that monitored the SCR, ensuring that the corrosion prevention safeguards were working, and verifying that the corrosion rate was in line with expectations.
- Loy-Lange did not establish an inspection program that addressed the SCR's corrosion and thinning.
- An internal inspection or use of ultrasonic thickness measurement could have identified the SCR's corrosion and thinning.

Loy-Lange's insurer, FM Global, also never inspected the SCR (Section 1.8.2.3). Although FM Global asserted that its rationale for not conducting a jurisdictional inspection of the SCR was the City of St. Louis's Code, the Code does not prohibit insurance companies from inspecting pressure vessels. The CSB concludes that FM Global was not prohibited by the City of St. Louis from performing an internal inspection of the SCR.



## 2.2.6 The City of St. Louis Missed Opportunities

The CSB requested inspection records from the City of St. Louis. The most recent inspection record of any kind the city submitted to the CSB for the Loy-Lange facility was a 2010 inspection of the Loy-Lange steam generators. The records the city produced to the CSB show that during the 20-year service life of the SCR (1997-2017), the city inspected the Loy-Lange steam system only four times: 1998, 1999, 2007 and 2010 (Sections 1.9.4). None of the records produced include inspection records for the SCR. However, the SCR was not registered with the City, and thus the City had no means of proactively initiating an inspection of the SCR, because the City had no knowledge of the vessel (Section 1.9.4). The CSB concludes the City of St. Louis did not inspect the SCR primarily because Loy-Lange did not register it with the City.

The City of St. Louis was enabled by its Code to place a stop work order upon unpermitted boilers or pressure vessels and to seal such equipment from operation (Section 1.9.2). Thus, were a City inspector ever to discover the unregistered SCR, the City had a regulatory means to ensure that the vessel was thereafter appropriately registered and inspected. Such an identification could have occurred during the annually required inspection of the Loy-Lange steam generators, which were registered with the City. As shown in **Figure 3**, the SCR was physically situated directly next to one of the Loy-Lange steam generators. However, as previously discussed, the City only inspected the Loy-Lange steam generators four times during the service life of the SCR, and hadn't done so since 2010. The CSB concludes that

- The City of St. Louis had the opportunity and authority to identify, seal from operation, and ensure the inspection of the SCR despite the vessel being unregistered.
- Had the City of St. Louis identified, sealed from operation, and ensured the inspection of the SCR, this incident could have been prevented.

Further, because the City was not regularly inspecting the Loy-Lange steam generators, which were registered with the City, the SCR's lack of registration is not the sole causal factor associated with the City of St. Louis never inspecting the SCR. As discussed in Section 1.9.5, the City of St. Louis mechanical inspection office was understaffed and the office de-prioritized the inspection of boilers and pressure vessels in favor of other mechanical equipment in the city. Thus, by not regularly inspecting the Loy-Lange steam generators, as was required by its Mechanical Code, the City of St. Louis missed opportunities to identify the unpermitted pressure vessel, given the close proximity of the SCR to one of the Loy-Lange steam generators. The CSB concludes that resource limitations contributed to the City of St. Louis's irregular inspection of the Loy-Lange facility, which contributed to the City's missed opportunities to identify and inspect the SCR.

## 2.2.7 Changes and Gaps in the City of St. Louis Inspection Requirements

In 2018, the City of St. Louis adopted a new ordinance (ordinance 70800) that replaced the 2010 ordinance in effect at the time of the Loy-Lange explosion. The ordinance<sup>a</sup> [23] adopts the 2018 edition of the IMC [24] verbatim, except as specifically amended by the city via the ordinance. The following amendment was added to the ordinance:

<sup>a</sup> City of St. Louis Ordinance number 70800 can be found here:

<https://www.stlouis-mo.gov/government/city-laws/upload/legislative//Ordinances/BOAPdf/70800.pdf>

Annual inspections shall be performed by the code official or approved third party testing agency on the following mechanical equipment: auto lifts, boilers, unfired pressure vessels, refrigeration systems for which monitoring equipment is required, and equipment used for smoke control.<sup>a</sup>

The boiler and pressure vessel inservice inspection requirement was changed as follows:

All boilers, steam generators, and pressure vessels subject to the provisions of this code shall be inspected annually **by an approved independent third party testing agency**. Inspection reports shall be filed with the Mechanical Section of the Building Division.<sup>b</sup> (emphasis added)

The City also includes the requirement that third party inspectors hold NBBI certification:

Any boiler that is required to be operated by a Stationary Engineer per [...] this code shall be inspected annually by an independent inspector that is certified with [NBBI]. Copies of these independent inspection reports shall be provided to the [City of St. Louis] Section of Mechanical Equipment Inspection.<sup>c</sup>

Thus, as of 2018, the City Code allows inspections to be performed by an outside entity, rather than by the City itself, and the City requires third party inspectors to hold NBBI certification. However, the requirement for NBBI certification only explicitly applies to inspections of boilers and does not explicitly mention pressure vessels. Further, in a written response to a CSB information request, the City of St. Louis stated that City inspectors are not required to hold NBBI commission. The City stated:

“These types of certifications are not listed in [the] City Dept. of Personnel classification for ‘Mechanical Inspector,’ nor are they listed in City Mechanical Ordinance 70800.”

Thus, the CSB concludes that:

- Under the St. Louis City Code only boilers inspected by third party inspectors are currently required to undergo inspection by an NBBI-commissioned inspector. The City Code does not explicitly require either boilers inspected by City inspectors, or any pressure vessels, to be inspected by an NBBI-commissioned inspector in the City of St. Louis.
- Public safety in the City of St. Louis would benefit from all boilers and pressure vessels undergoing inspection by NBBI commissioned inspectors.

Therefore, the CSB recommends to the City of St. Louis Board of Aldermen to:

<sup>a</sup> St. Louis, Missouri, Municipal Code § 70800-301.19.

<sup>b</sup> St. Louis, Missouri, Municipal Code § 70800-1001.2.

<sup>c</sup> St. Louis, Missouri, Municipal Code § 70800-301.19.1.

- Revise the City of St. Louis Mechanical Code to require City of St. Louis mechanical inspectors tasked with inspecting boilers and pressure vessels to hold NBBI inservice (IS) commissions.
- Revise the City of St. Louis mechanical code to explicitly require third party pressure vessel inspectors to hold NBBI inservice (IS) commissions.

In the 2018 revisions to the City Mechanical Code, the city removed the clause requiring inspections to “be as thorough as circumstances permit.” However, while the City of St. Louis adopts codes and standards for other mechanical operations—for example the ASME BPVC for fabrication and installation, and NBIC Part 3 for repair and alteration—the City of St. Louis has not explicitly adopted any standards for the inservice inspection of boilers and pressure vessels. Further, according to the City, the City uses no inspection procedures in the performance of boiler and pressure vessel inspections, and the City’s current ordinance (70800) contains all standards to which City inspectors are to inspect. As already discussed, however, City of St. Louis ordinance 70800 does not adopt any inspection standard such as API 510 or NBIC Part 2. The only inservice inspection requirements in the City of St. Louis Mechanical Code are that:

- boilers and pressure vessels undergo annual inspection by either city inspectors or third-party inspectors; and,
- boilers (but not explicitly pressure vessels) inspected by third party inspectors must be inspected by an inspector holding an NBBI commission.

There is no requirement that either City inspectors or third-party inspectors adhere to any specific inspection standard when performing boiler and pressure vessel inspections in the City of St. Louis. As a result, even if a City or third-party inspector holds an NBBI commission, there is no requirement that such an inspector perform the inspection in accordance with NBIC Part 2 – only that the inspector must have the certification to do so. The use of NBIC Part 2 is therefore seemingly left up to the individual inspector’s discretion.

The CSB concludes that:

- Had any party, such as Loy-Lange via a third-party inspector, FM Global, or the City of St. Louis, inspected the SCR per the existing industry guidance contained in standards such as API 510 or NBIC Part 2, and subsequently taken appropriate follow-up action, this incident could have been prevented.
- The City of St. Louis should adopt a consensus standard, such as NBIC Part 2 *Inspection*, to which boilers and pressure vessels must be inspected to ensure that inspections are carried out per existing industry good practice.

Therefore, the CSB recommends to the City of St. Louis Board of Aldermen to revise the City of St. Louis Mechanical Code to adopt a national consensus standard such as NBIC Part 2 to govern the requirements for inservice inspection of boilers and pressure vessels.

## 2.2.8 Future Boiler and Pressure Vessel Inspections in the City of St. Louis

Despite the changes in the City’s mechanical code, not all boilers and pressure vessels are being inspected annually per City regulations. As discussed in Sections 1.9.5 and 1.12, there are 794 boilers and pressure vessels registered with the City as of April of 2022. According to the City, only 590 inspections have been conducted since the enactment of Ordinance 70800 in July of 2018. The City reported to the CSB that inspections were temporarily suspended in April of 2020 as a result of the SARS-CoV-2 pandemic but have since resumed on a “request-only” basis. The City indicated the rationale for the request-only model as two-fold: ongoing “manpower restrictions and the increased workload of a busy construction industry.” The City also indicated that this “request-only life safety model will be the standard in the next City ordinance cycle.”

Since July of 2018, the City has yet to conduct even one inspection for every boiler or pressure vessel registered in its records. It is thus likely that some boilers and pressure vessels are continuing to operate despite being uninspected. Going forward, the City will only perform inspection at the request of the owner/operator. The City of St. Louis code still requires that boilers and pressure vessels be inspected annually and prohibits them from operation unless they have been inspected. The City also allows for third-party inspection agencies to perform jurisdictional inspections.

Thus, the City of St. Louis has placed all responsibility for the performance of annual inspections on the owner/operator. Owner/operators can either request an inspection by City inspectors or by third-party inspection agencies. The inservice inspection of boilers and pressure vessels is a critical activity in the prevention of premature or catastrophic failure of boilers and pressure vessels. Such failures are capable of causing serious or fatal injuries and extensive property damage. It is in the best interest of entities that own or operate boilers and pressure vessels to inspect such equipment regardless of whether their respective jurisdiction requires it. It is the owning/operating entity’s primary responsibility for ensuring safety at its facility. Loy-Lange could have prevented the explosion by inspecting the SCR, discovering the unsafe thinning and corrosion, and reacting appropriately prior to vessel failure.

Given that inservice inspections in the City of St. Louis must now be exclusively initiated by the owner/operator, the CSB concludes that public safety in the City of St. Louis would benefit from the communication of the findings of this report to all registered stationary engineers and boiler and pressure vessel owning/operating entities in the City of St. Louis. The CSB recommends to the Mayor of the City of St. Louis to distribute and communicate the findings of this report to all licensed stationary engineers and all registered boiler and pressure vessel owning/operating entities in the City of St. Louis.

## 2.3 Pressure Vessel Repair

Once an unacceptable defect or nonconformity is found during inspection, the NBIC Part 3 *Repair and Alterations* requires a pressure vessel be de-rated, repaired, or replaced. As discussed below, the 2012 SCR repair did not conform to NBIC Part 3 *Repair and Alterations*.

### 2.3.1 The National Board “R-Stamp”

In 2012, at the time of Kickham’s repair to the SCR, the City of St. Louis Code required that repairs to pressure vessels be performed by an organization holding authorization from the NBBI [25] (Section 1.9.1). This authorization is formally called a National Board *R Certificate of Authorization* but is also commonly referred to in industry as an “*R-Stamp*.” Companies and organizations seeking to obtain or renew an NBBI R-Stamp authorization must [26]:

- Develop a written Quality System, detailing the policies and procedures the organization uses to ensure code compliance.
- Have and maintain a contract with an Authorized Inspection Agency.
- Apply for accreditation.
- Possess the latest mandatory edition of NBIC and other code documents as required.
- Undergo an audit of its work, Quality System, and facilities by an audit team consisting of personnel from the Authorized Inspection Agency, jurisdictional representatives as applicable, and NBBI representatives as applicable.

When all requirements have been met, the NBBI issues the company or organization an *R Certificate of Authorization* [26, p. 4]. Thus, companies and organizations possessing the authorization have been audited and have demonstrated the ability to perform NBIC-compliant repairs and alterations to pressure-retaining components. Upon completion of a repair per NBIC Part 3 *Repair and Alterations* requirements, repair organizations are required by NBIC Part 3 to fill out an *R-1 Report of Repair* form, which documents the repair.

By stamping the vessel with the National Board “R” symbol and by signing the Form R-1, the repair organization and the Repair Inspector declare that they have complied with all applicable requirements of NBIC. However, discussed below, the CSB found evidence that Kickham’s repair did not conform to NBIC Part 3 *Repair and Alterations*.

### 2.3.2 Inadequacy of the 2012 SCR Repair

NBIC requirements for pressure vessel repair are contained in Part 3 *Repair and Alterations*. Specific repair requirements depend upon many factors, including the repair technique selected. Regarding repairs in general, the NBIC states:

[...] a repair of a defect in a welded joint or base material shall not be made until the defect has been removed.<sup>a</sup>

During the 2012 repair, Kickham patched the SCR bottom head using a “*flush patch*.” The NBIC issues the following requirement for flush patches:

---

<sup>a</sup> NBIC Part 3 (2011), Paragraph 3.3.4.1.

Before installing a flush patch, the defective material should be removed until sound material is reached.<sup>a</sup>

Although Kickham said that it had removed all the corroded metal found in the bottom head (Section 1.3), two pieces of evidence gathered in the post-incident examination of the SCR indicate that damaged material remained:

- Destructive metallurgical cross-sectional examination shows that the reused ring was likely as thin as 0.101 inches at the time of repair in 2012 (shown below in **Figure 33**). Notably, this would have been less than half of the required minimum thickness (0.2204 inches) for the bottom head.
- Via non-destructive thickness examination, the post-incident thickness of the reused ring and the repair patch were measured in adjacent locations on either side of the weld (discussed in Section 1.6.2, shown below in **Figure 34**). The average measured thickness of the reused ring was 0.119 inches, and the average measured thickness of the patch material was 0.216 inches. Thus, post-incident, on average, the patch was roughly 80% thicker than the ring. It is not likely that the ring and patch were both the same thickness in 2012 when the repair was made, because if that was true, there would likely not be a significant difference in thickness in 2017.

According to Kickham, it used visual examination and a measuring tape to verify the thickness of the plate (Section 1.3). These methods, however, failed to detect the presence of the remaining corroded material. A more accurate quantitative measurement of the thickness of the re-used steel, such as the use of calipers or ultrasonic thickness measurement, may have prevented this incident by enabling Kickham to measure more precisely the thickness of the material it planned to leave in place and remove any material that did not meet the vessel's minimum thickness requirements.

---

<sup>a</sup> NBIC Part 3 (2011), Paragraph 3.3.4.6.a.2.

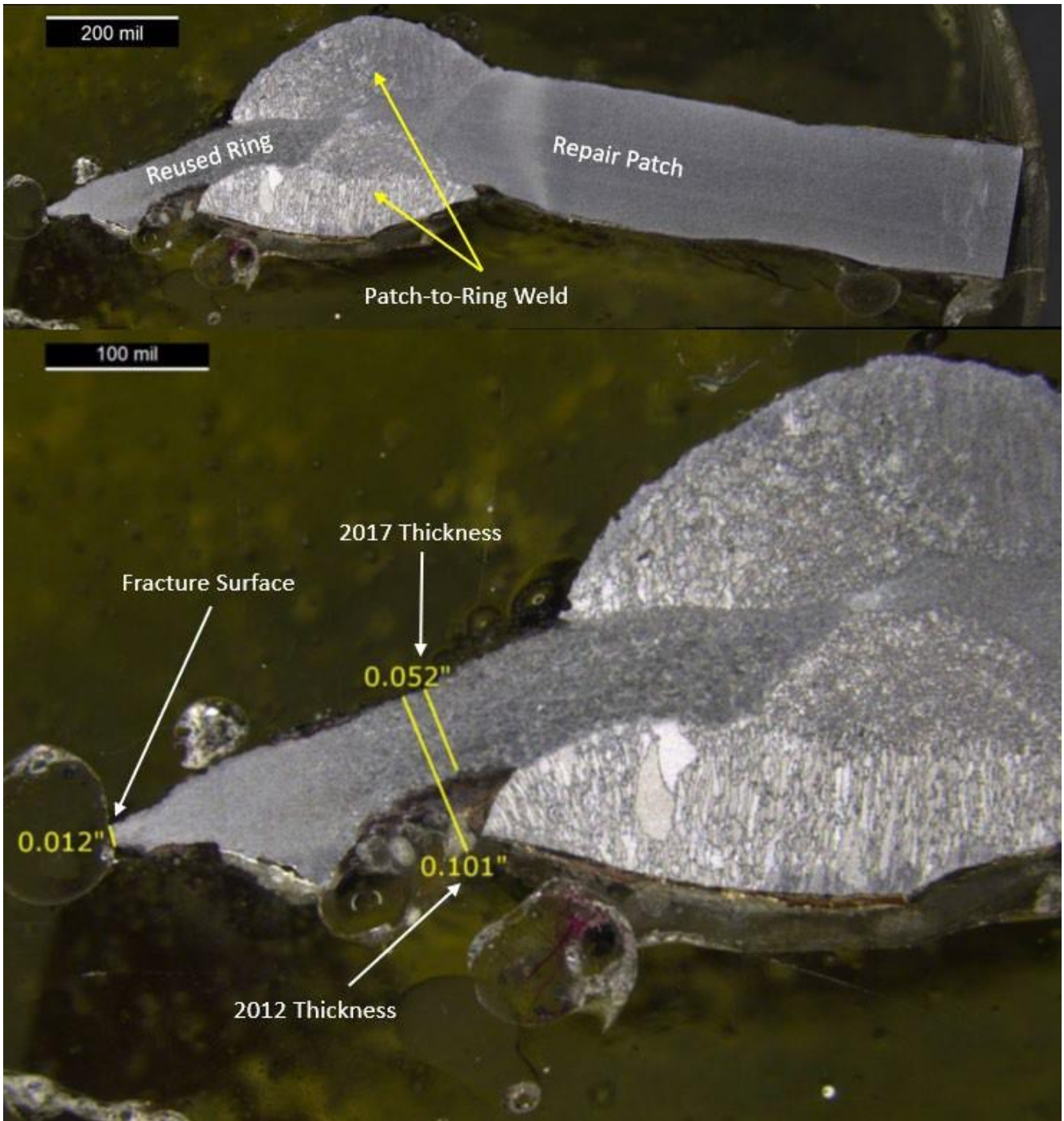

Figure 33. Metallurgical mount examination of a portion of the reused ring. (Credit: CSB)



**Figure 34.** Thickness comparison on either side of patch-to-ring weld. (Credit: CSB).

Based on the metallurgical examination and corrosion calculations, there is evidence that the 2012 repair did not remove all existing corrosion damage. It is important to remove all corroded material that is too thin to meet the vessel's minimum thickness requirements because a decrease in thickness could impact the pressure retaining ability of the vessel. The CSB concludes that Kickham likely left thinned material in place when it repaired the SCR bottom head in 2012, and in so doing did not adhere to the requirements of *NBIC Part 3 Repair and Alterations*.

To prevent this incident, Kickham needed to more accurately measure the thickness of the repair to ensure that all material in the SCR bottom head too thin to meet the minimum thickness requirements was removed as required by *NBIC Part 3 Repair and Alterations*. Once it was removed, Loy-Lange and Kickham should have evaluated the best method of repair. Given the probable extent of the corrosion damage at the time of Kickham's repair, the most likely successful repair may have been to fully replace the entire SCR bottom head by removing and replacing all material below the shell-to-head weld. The CSB concludes that had Kickham properly followed *NBIC Part 3* requirements, this incident could have been prevented.

Kickham Boiler and Engineering ceased operations in 2016 and was not in business at the time of the 2017 explosion at Loy-Lange. Therefore, the CSB makes no recommendation to Kickham.



### 2.3.3 The Repair Inspector

As part of the NBBI R-Stamp repair process, a Repair Inspector must be involved in the repair, as specified in *NB-263 Rules for Commissioned Inspectors* [27] [28]. The extent of the inspector's involvement depends upon several factors including repair complexity.

For inspection of an R-Stamp repair, at the time of the 2012 SCR repair, the Repair Inspector<sup>a</sup> had the following duties:

The Inspector should:

Verify the "R" Certificate Holder has a valid National Board "R" Certificate of Authorization and the activity is permitted under the scope of the certificate.

Verify the "R" Certificate Holder has the current NBIC and addenda.

Monitor the quality control system and verify the system is being implemented to the requirements of the NBIC.

Verify all material complies with the NBIC.

Verify all welding procedure specifications, procedure qualification records, and welder and welding operator qualification records conform to the NBIC.

Verify heat treatments as required by the NBIC have been performed and properly documented.

Verify nondestructive examinations and tests as required by the NBIC have been performed and properly documented.

Witness pressure tests as required by the NBIC.

Verify information in the NBIC report forms is correct and the responsible representative of the "R" Certificate Holder has signed it.

Verify the stamping or nameplate is correct and, where applicable, the nameplate has been properly attached [27, p. 15].

---

<sup>a</sup> At the time of the 2012 repair, the title "Repair Inspector" did not appear in NB-263. Instead, the duties were to be carried out by an NBBI commissioned inspector possessing an "Inservice Commission." Later editions of NB-263 added the title and role of Repair Inspector [27] [34] [28].

After Kickham's repair was complete, Loy-Lange restarted the steam system the following Monday. The vessel passed a hydrostatic leak test at 110 psi.<sup>a</sup> The repair inspector, employed by Arise, witnessed the hydrostatic pressure test but did not witness any other portion of the repair process. Kickham and the repair inspector documented the 2012 repair as a code-compliant, permanent repair; Kickham affixed an official repair stamp to the side of the SCR; and the inspector accepted the repair by signing the associated repair documentation.

At the time of the 2012 repair, the NBBI *Rules for Commissioned Inspectors* did not require repair inspectors to establish inspection points during the repair or require the inspector to meet in person with the repair organization prior to giving authorization for the repair. Thus, the level of scrutiny applied to any particular repair is dependent on the inspector's discretion which could be influenced by many factors. This discretion allowed the repair inspector, during Kickham's 2012 repair to the Loy-Lange SCR, to approve work without first evaluating the SCR and to not designate any inspection points for the repair except for witnessing the post-repair hydrostatic pressure test.

The CSB concludes:

- A repair inspector's initial evaluation of the damaged vessel is a critical step in determining whether the method of repair is appropriate.
- Had the repair inspector detected and refused to accept Kickham's non-conforming repair, this incident could have been prevented.

Since the 2012 repair, NBBI made significant changes to NB-263. NB-263 *Rules for Commissioned Inspectors* now requires inspectors to designate "inspection points at stages of the work that will provide meaningful results to verify NBIC and quality program requirements are met" and to perform those inspections.<sup>b</sup> Additionally, it requires the inspector to perform internal inspections whenever access permits and as required by NBIC and external inspections to verify NBIC compliance.<sup>c</sup> Despite these changes, there remains a gap in the *Rules for Commissioned Inspectors* that can allow for a nonconforming repair to go undetected. For example, the Rules do not specify whether the repair inspector has to make in-person contact or view the job prior to reviewing and accepting a repair plan.<sup>d</sup> Given the many factors and circumstances of pressure vessel repair, judgement is required on the part of the Repair Inspector, the Authorized Inspection Agency, and the R-Stamp repair company. Understanding the extent of the repair, however, is a critical step in determining the appropriateness of the repair. The absence of a requirement for in-person contact or visual inspection of the vessel needing repair prior to work, combined with the absence of a requirement for specific inspection points, leaves the same gap

<sup>a</sup> At the time of the 2012 repair, the City of St. Louis required that after repair, a hydrostatic pressure test be performed (St. Louis, Missouri, Municipal Code § 68639-1001.4). The City of St. Louis Code did not specify in that section the pressure conditions required during the test. In another part of the City of St. Louis Code (St. Louis, Missouri, Municipal Code § 68639-1011.1), the City of St. Louis required acceptance tests after installation of a pressure vessel, and that the test conform to ASME BPVC. The City also required (St. Louis, Missouri, Municipal Code § 68639-1011.1.1) that the "pressure for vessels previously in service shall conform to [NBIC as] listed in Chapter 15." Chapter 15 of the City of St. Louis Code referenced "NB-23 National Board Inspection Code" which is the entire NBIC. The 2011 edition of the NBIC Part 3 required in Paragraph 4.4.1.a.1 that the "test pressure shall be the minimum required to verify the leak tightness integrity of the repair, but not more than 150%" of the vessel's MAWP, which would have been 225 psi for the Loy-Lange SCR.

<sup>b</sup> NB-263, 2021 ed., Section 5-3.5, Paragraphs a and b.

<sup>c</sup> NB-263, 2021 ed., Section 5-3.5, Paragraph c.

<sup>d</sup> NB-263, 2021 ed., Section 5-3.4, Paragraph e.

that the 2012 Rules had because the repair inspector could adopt the same level of involvement as was in the case of the 2012 repair.

The CSB concludes that:

- To ensure that Arise repair inspectors do not accept non-conforming repairs, Arise should update its company policies and/or procedures by including prescriptive elements to the boiler and pressure vessel repair inspection and acceptance process that would prevent the acceptance of a non-conforming repair or alteration.
- To ensure that other Authorized Inspection Agencies and Repair Inspectors do not accept non-conforming repairs, the National Board of Boiler and Pressure Vessel Inspectors should update *NB-263 Rules for Commissioned Inspectors* to include prescriptive elements to the boiler and pressure vessel repair inspection and acceptance process that would prevent the acceptance of a non-conforming repair or alteration.

The CSB recommends to Arise to update company policies and/or procedures by including prescriptive elements in the boiler and pressure vessel repair and alteration inspection and acceptance process that would prevent the acceptance of a non-conforming repair or alteration.

The CSB recommends to the National Board of Boiler and Pressure Vessel Inspectors to update *NB-263 Rules for Commissioned Inspectors* to include prescriptive elements in the boiler and pressure vessel repair and alteration inspection and acceptance process that would prevent the acceptance of a non-conforming repair or alteration.

## 2.4 Process Safety Management Systems

### 2.4.1 Process Safety

According to CCPS, process safety management systems are “comprehensive sets of policies, procedures, and practices designed to ensure that barriers to episodic incidents are in place, in use, and effective [29].” A process safety management system will have a variety of programs to address process safety. In addition to process safety, chemical manufacturing facilities typically also have programs to address personal safety. Personal safety<sup>a</sup> programs and process safety<sup>b</sup> programs are distinct, and both are important.

<sup>a</sup> “Personal safety” incidents affect individual workers, resulting in first aid cases, recordable injuries, lost-time injuries, or fatalities. Typical causes of personal safety incidents include slips, trips, falls, lacerations, and dropped objects. Personal safety programs try to reduce the number of worker injuries from these types of hazards by managing individual behaviors. Common areas that personal safety programs address include personal protective equipment, stop work authority programs, working at heights, hazardous material communications, confined space permitting, lockout/tagout, cranes and heavy lifts, area access controls, and vehicle operation.

<sup>b</sup> “Process safety” incidents, on the other hand, include chemical releases, fires, and explosions. Process safety incidents can result in large-scale destruction to site and community infrastructure and can lead to multiple injuries and fatalities. Process safety programs try to prevent these incidents by identifying and controlling the process hazards. Examples of process safety programs include process hazard analysis, inherently safer design, pressure relief systems, automated safety controls, operating procedures, management of change, audits, emergency response systems, and community involvement programs.

The CSB requested from Loy-Lange its policies or procedures for safety management systems including but not limited to hazard analysis, incident investigation and mechanical integrity. Although Loy-Lange was able to produce information and policies regarding personal safety (Appendix C), Loy-Lange did not produce any formal company safety or operational policies or procedures regarding hazard analysis, incident investigation or mechanical integrity, typical components of a process safety management system.

Companies create their own safety management systems to address regulatory requirements, including those under OSHA's Process Safety Management (PSM) standard and the EPA's Risk Management Plan (RMP) rule. These federal safety regulations provide a process safety management system framework for companies to use in developing their own programs. In its PSM standard,<sup>a</sup> OSHA issued minimum safety management system requirements for certain processes using threshold quantities of flammable materials or individually listed chemicals.<sup>b</sup> Similar to OSHA's PSM standard, the RMP rule applies to facilities that the Clean Air Act defines as stationary sources of air pollution, and that use or store specific regulated substances that the EPA has determined to be extremely hazardous in nature. If any of the specified toxic chemicals or flammable substances are present at a facility at or above established threshold quantities listed by the EPA in its regulation, then the RMP rule applies to the chemical process using that substance at that facility.<sup>c</sup> The Loy-Lange process did not use chemicals that would trigger either the OSHA PSM standard or EPA RMP rule.

Gaps in Loy Lange's process safety management system were enforced under Section 5(a)(1) of the OSH Act,<sup>d</sup> which is known as the General Duty Clause. Section 5(a)(1) requires all employers to "furnish to each of his employees employment and a place of employment which are free from recognized hazards that are causing or are likely to cause death or serious physical harm to his employees."<sup>e</sup> OSHA conducted an inspection of Loy-Lange after the incident and issued nine citations, two of which related directly to the Loy-Lange steam system.<sup>f</sup> Under the General Duty Clause requirement, OSHA cited Loy-Lange for failing to "furnish a place of employment [...] free from recognized hazards [...] relating to the catastrophic corrosion failure and subsequent explosion of a pressure vessel" and for "failing to ensure pressure relief valves are set at or below the [MAWP]" of the SCR [30]. Some of the acceptable methods of abatement for this incident stated by OSHA were:

Developing and implementing measures to effectively monitor, control, discover, maintain and repair corrosion damage in the steam generation system [...] by (i) responding when leaks in pressure vessels are discovered, including removing leaking pressure vessels from service [...], (ii) establishing an appropriate corrosion inspection and control program [...], (iii) maintaining an repairing the steam generation system [...] to prevent catastrophic leaks from

<sup>a</sup> 29 C.F.R. § 1910.119.

<sup>b</sup> The PSM standard applies to "(i) A process which involves a chemical at or above the specified threshold quantities listed in appendix A to this section; (ii) A process which involves a Category 1 flammable gas (as defined in 1910.1200(c)) or a flammable liquid with a flashpoint below 100°F (37.8°C) on-site in one location, in a quantity of 10,000 pounds (4,535.9 kg) or more except for: (A) Hydrocarbon fuels used solely for workplace consumption as a fuel (e.g., propane used for comfort heating, gasoline for vehicle refueling), if such fuels are not a part of a process containing another highly hazardous chemical covered by this standard; (B) Flammable liquids with a flashpoint below 100°F (37.8°C) stored in atmospheric tanks or transferred which are kept below their normal boiling point without benefit of chilling or refrigeration." The PSM standard does not apply to "(i) Retail facilities; (ii) Oil or gas well drilling or servicing operations; or (iii) Normally unoccupied remote facilities" (29 C.F.R. § 1910.119(a)).

<sup>c</sup> 40 C.F.R. Part 68.

<sup>d</sup> [The OSH Act of 1970 \(Jan. 1, 2004\).](#)

<sup>e</sup> [29 U.S.C. § 654 \(a\) \(2010\).](#)

<sup>f</sup> The other seven citations were for other violations unrelated to the SCR explosion.

occurring, and (iv) training supervisors and employees in the hazards of corrosion failure [...].

These methods of abatement can be grounded in the establishment of a process safety management system. For example, these abatement methodologies are akin to management system elements in the PSM standard including hazard analysis, incident investigation, mechanical integrity, and training.

While Loy Lunge was not covered by either OSHA's PSM standard or EPA's RMP rule which require the development of a process safety management system, it is critical that companies still develop and implement such systems to help prevent catastrophic incidents, such as the incident that occurred at Loy-Lunge. CCPS introduced in its *Guidelines for Risk-Based Process Safety* [21] a risk-based approach for industries that manufacture, consume, or handle hazardous chemicals or energy that encourages companies to:

- Evolve their approach to accident prevention from a compliance-based to a risk-based strategy.
- Continuously improve management system effectiveness.
- Employ process safety management for non-regulatory processes using risk-based design principles.
- Integrate the process safety business case into an organization's business processes.
- Focus their resources on higher risk activities [21, p. 3].

As seen in CCPS's *Guidelines for Risk-Based Process Safety* and OSHA's abatement methodologies, organizations and regulatory agencies advocate that process safety be expanded outside the explicit minimums of regulatory compliance and regulated processes to encompass processes like the Loy-Lunge steam generation system. The CSB concludes that it is essential that facilities with hazardous processes have an effective process safety management system to help ensure major incidents such as the Loy-Lunge incident are prevented.

Industry guidance documents provide recommendations on developing process safety management systems. For example, CCPS, in *Guidelines for Risk-Based Process Safety*, identifies four foundational blocks that support 20 elements for its risk-based process safety management framework, illustrated below by CCPS in **Figure 35**. The four foundational blocks are as follows:

- 1) Commit to Process Safety – through elements such as process safety culture, workforce involvement, and stakeholder outreach;
- 2) Understand Hazards and Risk – through elements such as process knowledge management and hazard identification and risk analysis;
- 3) Manage Risk – through elements such as operating procedures, asset integrity and reliability, and management of change;
- 4) Learn from Experience – through elements such as incident investigation and auditing (of safety systems) [21, pp. 23-24].

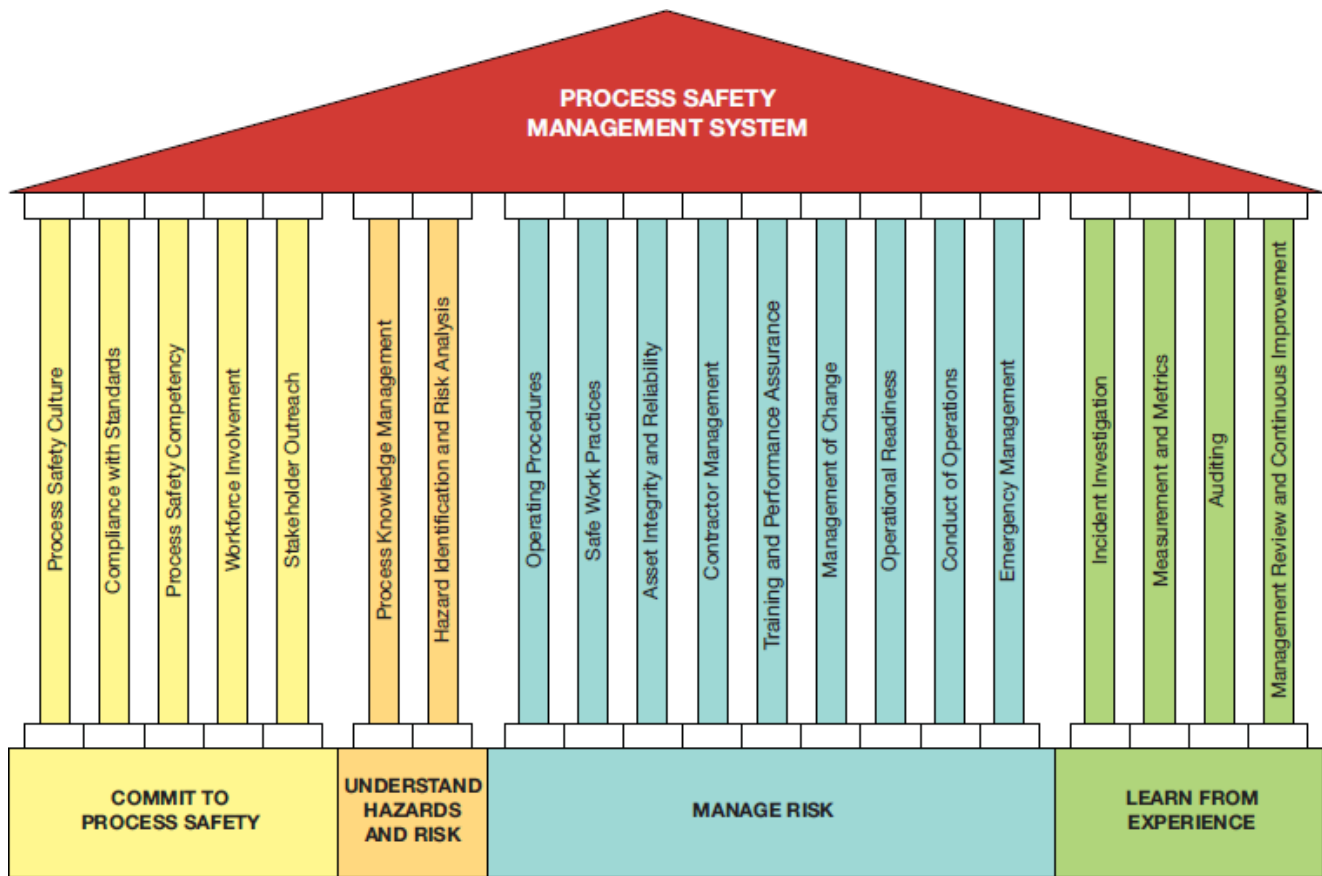

**Figure 35.** The CCPS Risk-Based Process Safety Management System. (Credit: CCPS)

To prevent this incident, Loy-Lange needed to establish a foundation for a process safety management system as recommended by CCPS. At a minimum, Loy Lange should have:

- 1) committed to process safety by establishing a process safety culture that would have prevented the startup of a leaking pressure vessel;
- 2) understood the hazards and analyzed risks of its operation, including the risks of starting up a leaking pressure vessel and the mechanisms by which oxygen could enter and remain in its steam system;
- 3) managed risk by implementing and maintaining safeguards to prevent oxygen—and therefore corrosion—in its steam system; and,
- 4) learned from experience by conducting incident investigations and improving safeguards to ensure their proper function.

To prevent this incident, Loy-Lange needed to employ sound process safety management principles. A robust process safety management system would have established a strong process safety culture and would have contained multiple programs that could have identified the hazards, analyzed the risks, and mitigated the risks of its operations, and which would have enabled Loy-Lange to learn from its operational experience.

Loy-Lange's process safety culture was such that the company normalized the occurrence of leaks in its steam system. Loy-Lange's management personnel did not understand the hazards of its operation, and neither its management personnel nor its stationary engineers regarded a leaking pressure vessel as a safety issue that could indicate that the pressure vessel's integrity was compromised (Section 1.8.4). Loy-Lange's corrosion prevention efforts failed, as Loy Lange did not ensure oxygen was effectively prevented from entering, or removed from, its steam system (Section 1.7). The company had no mechanical integrity program to ensure that its corrosion prevention efforts were successful (Section 1.8.1). The company never investigated or determined the cause of the chronic corrosion in the SCR or the rest of its steam system (Section 1.8.3). Finally, Loy-Lange allowed the SCR to corrode, thin, and leak multiple times (Section 1.8.1) and operated the vessel while it was leaking on the morning of the explosion (Section 1.5). The CSB concludes that:

- Loy-Lange did not have a comprehensive process safety management system.
- Had Loy-Lange had a comprehensive process safety management system requiring the control and prevention of steam system corrosion, pressure vessel inspection, investigation of leaks, and pressure vessel repair quality assurance, the incident could have been prevented.

The CSB recommends to Loy-Lange to develop and implement a comprehensive safety management system. Loy-Lange should include in that system process safety elements recommended in industry guidance publications, such as the Center for Chemical Process Safety (CCPS) publication *Guidelines for Risk Based Process Safety*.

## 2.4.2 Records Retention

An essential part of a robust safety management system is the development of policies, procedures, and other documents, as well as employing methods to ensure those documents are stored such that they are preserved and accessible for employee use. Loy-Lange told the CSB that many of its company records, policies, and procedures relevant to the management, operation and maintenance of its steam system were destroyed in the explosion. Loy-Lange relied upon handwritten records detailing the operating conditions of the steam system and the water treatment program. Loy-Lange also did not have any system to record process data, such as a digital historian capable of automatically recording and storing real-time steam system pressures, temperatures, flow rates, or liquid levels.

The CSB concludes that:

- Loy-Lange did not take effective action to ensure that policies, procedures, and records critical to the management, operation and maintenance of its steam system were stored in such a manner that would prevent their destruction in a catastrophic incident.
- To ensure that its important corporate information is not placed at risk by the occurrence of an incident at its facility, Loy-Lange should implement an electronic records and data management system that preserves all critical company records, safety policies and procedures, and operational data, and ensures that such records are stored and can be accessed remotely in the event of a catastrophic incident.

The CSB recommends to Loy-Lange to implement an electronic records and data management system that preserves all critical company records, safety policies and procedures, and operational data. Ensure that such records are stored and can be accessed remotely in the event of a catastrophic incident.

## 3 Conclusions

### 3.1 Findings

#### Exclusionary Findings

1. Weather was not a causal factor in the occurrence of this incident.
2. While there was a large steam plume releasing from the Loy Lange building before the incident and the SCR was equipped with a pressure relief valve with a set pressure greater than the vessel's Maximum Allowable Working Pressure (MAWP), there was insufficient evidence to determine if there was an overpressure event in the SCR at the time of the SCR failure.

#### Pressure Vessel Corrosion Findings

3. The Loy-Lange SCR ruptured due to extensive oxygen corrosion that reduced its wall thickness, which prevented the SCR from containing its operating pressure.
4. Had Loy-Lange effectively prevented corrosion in its steam system, the SCR likely would not have failed due to excessive thinning.
5. The catastrophic circumferential failure of the SCR bottom head resulted in a rapid pressure reduction upon the water inside the vessel, which resulted in a boiling liquid expanding vapor explosion, or BLEVE.
6. Loy-Lange and its contractors did not effectively monitor, remove, or treat the dissolved oxygen in the steam generation system's water.
7. Loy-Lange likely introduced oxygen into the SCR during its daily startup operation.

#### Pressure Vessel Inspection and Regulation Findings

8. Loy-Lange did not ensure that the SCR was appropriately permitted as required by the City of St. Louis.
9. Loy-Lange did not have a robust mechanical integrity program that ensured the SCR was operating safely as intended and designed.
10. Loy-Lange never conducted an incident investigation when corrosion was found in the steam generation system.
11. Loy-Lange could have prevented the 2017 incident if it had conducted an effective incident investigation after the 2004 or 2012 SCR corrosion failures and implemented corrective actions



including establishing an inspection program that monitored the SCR, ensuring that the corrosion prevention safeguards were working, and verifying that the corrosion rate was in line with expectations.

12. Loy-Lange did not establish an inspection program that addressed the SCR's corrosion and thinning.
13. An internal inspection or use of ultrasonic thickness measurement could have identified the SCR's corrosion and thinning.
14. FM Global was not prohibited by the City of St. Louis from performing an internal inspection of the SCR.
15. The City of St. Louis did not inspect the SCR primarily because Loy-Lange did not register it with the City.
16. The City of St. Louis had the opportunity and authority to identify, seal from operation, and ensure the inspection of the SCR despite the vessel being unregistered.
17. Had the City of St. Louis identified, sealed from operation, and ensured the inspection of the SCR, this incident could have been prevented.
18. Resource limitations contributed to the City of St. Louis's irregular inspection of the Loy-Lange facility, which contributed to the City's missed opportunities to identify and inspect the SCR.
19. Under the St. Louis City Code only boilers inspected by third party inspectors are currently required to undergo inspection by an NBB-commissioned inspector. The City Code does not explicitly require either boilers inspected by City inspectors, or any pressure vessels, to be inspected by an NBB-commissioned inspector in the City of St. Louis.
20. Public safety in the City of St. Louis would benefit from all boilers and pressure vessels undergoing inspection by NBB-commissioned inspectors.
21. Had any party, such as Loy-Lange via a third-party inspector, FM Global, or the City of St. Louis, inspected the SCR per the existing industry guidance contained in standards such as API 510 or NBIC Part 2, and subsequently taken appropriate follow-up action, this incident could have been prevented.
22. The City of St. Louis should adopt a consensus standard, such as NBIC Part 2 *Inspection*, to which boilers and pressure vessels must be inspected to ensure that inspections are carried out per existing industry good practice.
23. Public safety in the City of St. Louis would benefit from the communication of the findings of this report to all registered stationary engineers and boiler and pressure vessel owning/operating entities in the City of St. Louis.

#### Pressure Vessel Repair Findings

24. Kickham likely left thinned material in place when it repaired the SCR bottom head in 2012, and in so doing did not adhere to the requirements of NBIC Part 3 Repair and Alterations.
25. Had Kickham properly followed NBIC Part 3 requirements, this incident could have been prevented.

26. A repair inspector's initial evaluation of the damaged vessel is a critical step in determining whether the method of repair is appropriate.
27. Had the repair inspector detected and refused to accept Kickham's non-conforming repair, this incident could have been prevented.
28. To ensure that Arise repair inspectors do not accept non-conforming repairs, Arise should update its company policies and/or procedures by including prescriptive elements to the boiler and pressure vessel repair inspection and acceptance process that would prevent the acceptance of a non-conforming repair or alteration.
29. To ensure that other Authorized Inspection Agencies and Repair Inspectors do not accept non-conforming repairs, the National Board of Boiler and Pressure Vessel Inspectors should update *NB-263 Rules for Commissioned Inspectors* to include prescriptive elements to the boiler and pressure vessel repair inspection and acceptance process that would prevent the acceptance of a non-conforming repair or alteration.

#### Process Safety Management Systems Findings

30. It is essential that facilities with hazardous processes have an effective process safety management system to help ensure major incidents such as the Loy-Lange incident are prevented.
31. Loy-Lange did not have a comprehensive process safety management system.
32. Had Loy-Lange had a comprehensive process safety management system requiring the control and prevention of steam system corrosion, pressure vessel inspection, investigation of leaks, and pressure vessel repair quality assurance, the incident could have been prevented.
33. Loy-Lange did not take effective action to ensure that policies, procedures, and records critical to the management, operation and maintenance of its steam system were stored in such a manner that would prevent their destruction in a catastrophic incident.
34. To ensure that its important corporate information is not placed at risk by the occurrence of an incident at its facility, Loy-Lange should implement an electronic records and data management system that preserves all critical company records, safety policies and procedures, and operational data, and ensures that such records are stored and can be accessed remotely in the event of a catastrophic incident.

## **3.2 Cause**

The CSB determined the cause of the explosion was deficiencies in Loy-Lange's operations, policies, and process safety practices that failed to prevent or mitigate chronic corrosion in its Semi-Closed Receiver and Kickham Boiler and Engineering's performance of an inadequate repair to the SCR in 2012 that left damaged material in place. Contributing to the incident was Arise's acceptance of and failure to detect Kickham's inadequate repair, and gaps in Arise's and the National Board of Boiler and Pressure Vessel Inspectors' repair inspection requirements.

## 4 Recommendations

To prevent future chemical incidents, and in the interest of driving chemical safety change to protect people and the environment, the CSB makes the following safety recommendations:

### 4.1 The Loy-Lange Box Company

#### 2017-04-I-MO-R1

Develop and implement a comprehensive safety management system. Include in that system process safety elements recommended in industry guidance publications, such as the Center for Chemical Process Safety (CCPS) publication *Guidelines for Risk Based Process Safety*.

#### 2017-04-I-MO-R2

Engage a qualified third-party to conduct a comprehensive review or audit of Loy-Lange's regulatory compliance practices and current compliance status.

#### 2017-04-I-MO-R3

Implement an electronic records and data management system that preserves all critical company records, safety policies and procedures, and operational data. Ensure that such records are stored and can be accessed remotely in the event of a catastrophic incident.

### 4.2 The City of St. Louis Board of Aldermen

#### 2017-04-I-MO-R4

Revise the City of St. Louis Mechanical Code to adopt a national consensus standard such as NBIC Part 2 to govern the requirements for inservice inspection of boilers and pressure vessels.

#### 2017-04-I-MO-R5

Revise the City of St. Louis Mechanical Code to require pressure vessel inspections be performed by an NBBI inservice (IS) commissioned inspector.

### 4.3 The Mayor of the City of St. Louis

#### 2017-04-I-MO-R6

Distribute and communicate the findings of this report to all licensed stationary engineers and all registered boiler and pressure vessel owning/operating entities in the City of St. Louis.

## 4.4 Arise, Inc

### 2017-04-I-MO-R7

Update company policies and/or procedures by including prescriptive elements in the boiler and pressure vessel repair and alteration inspection and acceptance process that would prevent the acceptance of a non-conforming repair or alteration.

## 4.5 The National Board of Boiler and Pressure Vessel Inspectors

### 2017-04-I-MO-R8

Update *NB-263 Rules for Commissioned Inspectors* to include prescriptive elements in the boiler and pressure vessel repair and alteration inspection and acceptance process that would prevent the acceptance of a non-conforming repair or alteration.

# 5 Key Lessons for the Industry

The CSB urges companies to review the key safety lessons below for application at their facilities – particularly companies that operate pressure vessels and steam generation systems.

1. Pressure relief devices are typically the last line of defense protecting a vessel from overpressure. Companies must ensure that the pressure relief devices protecting their pressure vessels are properly designed, installed, and maintained, and must ensure that all pressure relief devices are set at the proper pressure. A pressure relief device with a set pressure greater than its vessel's maximum allowable working pressure (MAWP) cannot adequately protect the vessel from high pressure process upsets. Both American Society of Mechanical Engineers (ASME) and National Board of Boiler and Pressure Vessel Inspectors (NBBI) Code state that a pressure vessel's relief device shall not be set at a pressure higher than the vessel's MAWP.
2. Leaking pressure vessels can be dangerous and should be evaluated for continued fitness for service. When a pressure vessel leaks, its pressure retention ability may be compromised. The leak should be investigated, the cause(s) should be determined, the leak should be appropriately repaired prior to returning the vessel to service, and the cause(s) of the leak should be addressed to prevent recurrence.
3. Pressure vessels storing liquid at temperatures greater than its atmospheric boiling point can explode upon failure when the contents are suddenly exposed to atmospheric pressure. The explosion results from the rapid volume expansion that occurs when a liquid suddenly vaporizes. This type of explosion is known as a BLEVE. BLEVEs and other pressure vessel failures can be catastrophic and can cause injury, fatality, and significant property damage.
4. Ensure that damage mechanisms, such as corrosion, in pressure vessels and steam generation systems are adequately understood and controlled. Companies should understand the damage

mechanisms to which their steam systems and pressure vessels are vulnerable, the conditions that cause such mechanisms, and the means of preventing or otherwise controlling these damage mechanisms.

5. Pressure vessels must be regularly inspected, per regulatory requirements and per industry guidance, by appropriately credentialed inspectors.
6. Companies can hire contractors to perform pressure vessel inspections to supplement any local or state regulatory inspections. Many companies exist that employ inspectors with ASME, API, NBBI, and American Society for Nondestructive Testing certifications.
7. Ensure that an effective process safety management system is in place to identify equipment hazards that can lead to injury or fatality. Investigate incidents and near misses in which those hazards were not adequately controlled. Ensure that incident investigations are driven to uncover underlying process safety management system gaps, and that those gaps are appropriately addressed.

## 6 References

- [1] Loy-Lange Box Company, "History," 2008. [Online]. Available: <http://www.loylangebox.com/history.html>. [Accessed 5 April 2018].
- [2] U.S. Bureau of Labor Statistics, "Stationary Engineers and Boiler Operators: Occupational Outlook Handbook," [Online]. Available: <https://www.bls.gov/ooh/production/stationary-engineers-and-boiler-operators.htm>. [Accessed 16 December 2021].
- [3] American Alloy Fabricators, Inc., "Pressure Vessels," [Online]. Available: <https://americanalloyfab.com/pressure-vessels/>. [Accessed 16 December 2021].
- [4] American Petroleum Institute (API), RP 571 - Damage Mechanisms Affecting Fixed Equipment in the Refining Industry, 3rd ed., API, 2020.
- [5] United States Department of Defense, Unified Facilities Criteria Publication 3-240-13FN Industrial Water Treatment Operation and Maintenance, United States Department of Defense, 2005.
- [6] Association for Materials Protection and Performance (AMPP), "Pitting Corrosion," [Online]. Available: <https://www.ampp.org/resources/impact/corrosion-basics/group-1/pitting-corrosion>. [Accessed 06 January 2022].
- [7] J. W. McCoy, The Chemical Treatment of Boiler Water, New York, NY: Chemical Publishing Company, 1981.
- [8] Water Treatment Basics, "Explained: How Does a Deaerator Work? - Boiler Water Treatment," [Online]. Available: <https://watertreatmentbasics.com/how-does-deaerator-work/>. [Accessed 17 July 2020].
- [9] Center for Chemical Process Safety (CCPS), Guidelines for Vapor Cloud Explosion, Pressure Vessel Burst, BLEVE and Flash Fire Hazards, 2nd ed., Hoboken, NJ: John Wiley & Sons, Inc., 2010.
- [10] International Code Council (ICC), International Mechanical Code (IMC), 2009 ed., International Code Council, 2008.
- [11] The City of St. Louis, "Ordinance 68639 -- Mechanical Code," 21 April 2010. [Online]. Available: <https://www.stlouis-mo.gov/government/city-laws/upload/legislative//Ordinances/BOAPdf/68639x00.pdf>. [Accessed 15 Nov 2021].
- [12] Weather Underground, "St. Louis, MO Weather History," 03 April 2017. [Online]. Available: <https://www.wunderground.com/history/daily/KSTL/date/2017-4-3>. [Accessed 18 October 2021].
- [13] U.S. Occupational Safety and Health Administration, "Instruction Pub 8-1.5, Guidelines for Pressure Vessel Safety Assessment," U.S. Department of Labor, 1989.
- [14] The National Board of Boiler and Pressure Vessel Inspectors, "About Us," [Online]. Available: <https://www.nationalboard.org/index.aspx?pageID=102>. [Accessed 30 March 2022].
- [15] The National Board of Boiler and Pressure Vessel Inspectors (NBBI), "The National Board of Boiler and Pressure Vessel Inspectors," 2020. [Online]. Available: <http://www.nationalboard.org/PrintAllSynopsis.aspx?Jurisdiction=Select>. [Accessed 12 May 2020].
- [16] The National Board of Boiler and Pressure Vessel Inspectors (NBBI), "Inspection Code," [Online]. Available: <https://www.nationalboard.org/Index.aspx?pageID=4>. [Accessed 9 December 2021].
- [17] The National Board of Boiler and Pressure Vessel Inspectors (NBBI), *National Board Inspection Code, Part 2: Inspection*, 2021 ed., Columbus, OH: NBBI.
- [18] Missouri Code of State Regulations, "Missouri Code of State Regulations: Title 11 - Department of Public Safety," [Online]. Available: <https://www.sos.mo.gov/cmsimages/adrules/csr/current/11csr/11c40-2.pdf>. [Accessed 11 May 2020].
- [19] Missouri Revisor of Statutes, "Missouri Revisor of Statutes - Revised Statutes of Missouri, RSMo Section 650.290," 28 August 1984. [Online]. Available: <https://revisor.mo.gov/main/OneSection.aspx?section=650.290>. [Accessed 11 May 2020].
- [20] Center for Chemical Process Safety (CCPS), "CCPS Process Safety Glossary | AIChE," American Institute of Chemical Engineers (AIChE), [Online]. Available: <https://www.aiche.org/ccps/resources/glossary?title=mechanical+integrity#views-exposed-form-glossary-page>. [Accessed 26 May 2022].
- [21] Center for Chemical Process Safety (CCPS), Guidelines for Risk Based Process Safety, Hoboken, NJ: John Wiley & Sons, 2007.
- [22] Center for Chemical Process Safety (CCPS), A Practical Approach to Hazard Identification for Operations and Maintenance Workers, Hoboken, NJ: John Wiley & Sons, Inc., 2010.
- [23] The City of St. Louis, "Ordinance 70800 -- Mechanical Code," 11 May 2018. [Online]. Available: <https://www.stlouis-mo.gov/government/city-laws/upload/legislative//Ordinances/BOAPdf/70800.pdf>. [Accessed 15 Nov 2021].
- [24] International Code Council (ICC), International Mechanical Code (IMC), 2018 ed., International Code Council, 2017.
- [25] The National Board of Boiler and Pressure Vessel Inspectors (NBBI), *National Board Inspection Code Part 3 Repairs and Alterations*, 2019 ed., Columbus, OH: NBBI, 2021.
- [26] The National Board of Boiler and Pressure Vessel Inspectors (NBBI), *NB-415 Accreditation of "R" Repair Organizations*, Columbus, OH: NBBI, 2018.

- [27] The National Board of Boiler and Pressure Vessel Inspectors (NBBI), *NB-263 Inservice and New Construction Commissioned Inspectors*, 2012 ed., Columbus, OH: NBBI, 2012.
- [28] The National Board of Boiler and Pressure Vessel Inspectors (NBBI), *NB-263 Rules for Commissioned Inspectors*, 2021 ed., Columbus, OH: NBBI, 2021.
- [29] Center for Chemical Process Safety (CCPS), "CCPS Process Safety Glossary | AIChE," American Institute of Chemical Engineers (AIChE), [Online]. Available: <https://www.aiche.org/ccps/resources/glossary?title=process+safety+management+system#views-exposed-form-glossary-page>. [Accessed 26 May 2022].
- [30] U.S. Occupational Safety and Health Administration (OSHA), "Inspection Detail #1221846.015 - Loy-Lange Box Company," U.S. Department of Labor (USDOL), [Online]. Available: [https://www.osha.gov/pls/imis/establishment.violation\\_detail?id=1221846.015&citation\\_id=01001](https://www.osha.gov/pls/imis/establishment.violation_detail?id=1221846.015&citation_id=01001). [Accessed 27 April 2022].
- [31] "Explained: How Does a Deaerator Work? - Boiler Water Treatment," [Online]. Available: <https://watertreatmentbasics.com/how-does-deaerator-work/>. [Accessed 17 July 2020].
- [32] U.S. Chemical Safety Board, "Board Order 22: Recommendations Program," [Online]. Available: [https://www.csb.gov/assets/record/csb\\_board\\_order\\_022\\_final\\_20161.pdf](https://www.csb.gov/assets/record/csb_board_order_022_final_20161.pdf).
- [33] U.S. Chemical Safety Board (USCSB), "Board Order 40: Investigation Program," [Online]. Available: [https://www.csb.gov/assets/record/board\\_order\\_040\\_approved\\_2\\_14\\_17.pdf](https://www.csb.gov/assets/record/board_order_040_approved_2_14_17.pdf).
- [34] The National Board of Boiler and Pressure Vessel Inspectors (NBBI), *NB-263 Rules for Commissioned Inspectors*, 2017 ed., Columbus, OH: NBBI, 2017.
- [35] The National Board of Boiler and Pressure Vessel Inspectors (NBBI), *NB-264, Rev. 13: Criteria for Registration*, Columbus, OH: NBBI, 2016.
- [36] L. Huchler, *Operating Practices for Industrial Water Management*, vol. 1: Influent Water Systems, Houston, TX: Gulf Publishing Company, 2007.
- [37] American Forest and Paper Association (AF&PA), "Paper Packaging," [Online]. Available: <https://www.afandpa.org/paper-wood-products/packaging>. [Accessed 16 December 2021].
- [38] American Society of Mechanical Engineers (ASME), *ASME Boiler and Pressure Vessel Code, Section VIII, Division 1*, 2021 ed., New York, NY, 2021.
- [39] The National Board of Boiler and Pressure Vessel Inspectors (NBBI), *National Board Inspection Code Part 1 Installation*, 2021 ed., Columbus, OH, 2021.
- [40] Fibre Box Association, "What Is Corrugated? Detailed Information on Common Board Styles and Flutes.," [Online]. Available: <https://www.fibrebox.org/viewpage.aspx?ContentID=105>. [Accessed 19 June 2020].
- [41] U.S. Occupational Safety and Health Administration (OSHA), "Directives - Publication Date," U.S. Department of Labor (USDOL), [Online]. Available: <https://www.osha.gov/enforcement/directives/publicationdate>. [Accessed 7 June 2022].
- [42] Census Reporter, [Online]. Available: <https://censusreporter.org/>. [Accessed 14 July 2022].
- [43] Census Reporter, "About Census Reporter," [Online]. Available: <https://censusreporter.org/about/>. [Accessed 14 July 2022].
- [44] Census Reporter, "St. Louis, MO - Profile Data," [Online]. Available: <https://censusreporter.org/profiles/16000US2965000-st-louis-mo/>. [Accessed 2022 July 15].
- [45] United States Census Bureau, "Historical Income Tables: People," [Online]. Available: <https://www.census.gov/data/tables/time-series/demo/income-poverty/historical-income-people.html>. [Accessed 15 July 2022].
- [46] U.S. Occupational Safety and Health Administration (OSHA), "Inspection Detail #1221846.015 - Loy-Lange Box Company," U.S. Department of Labor (USDOL), [Online]. Available: [https://www.osha.gov/pls/imis/establishment.violation\\_detail?id=1221846.015&citation\\_id=01002](https://www.osha.gov/pls/imis/establishment.violation_detail?id=1221846.015&citation_id=01002). [Accessed 25 July 2022].

# Appendix A—Causal Analysis (AcciMap)

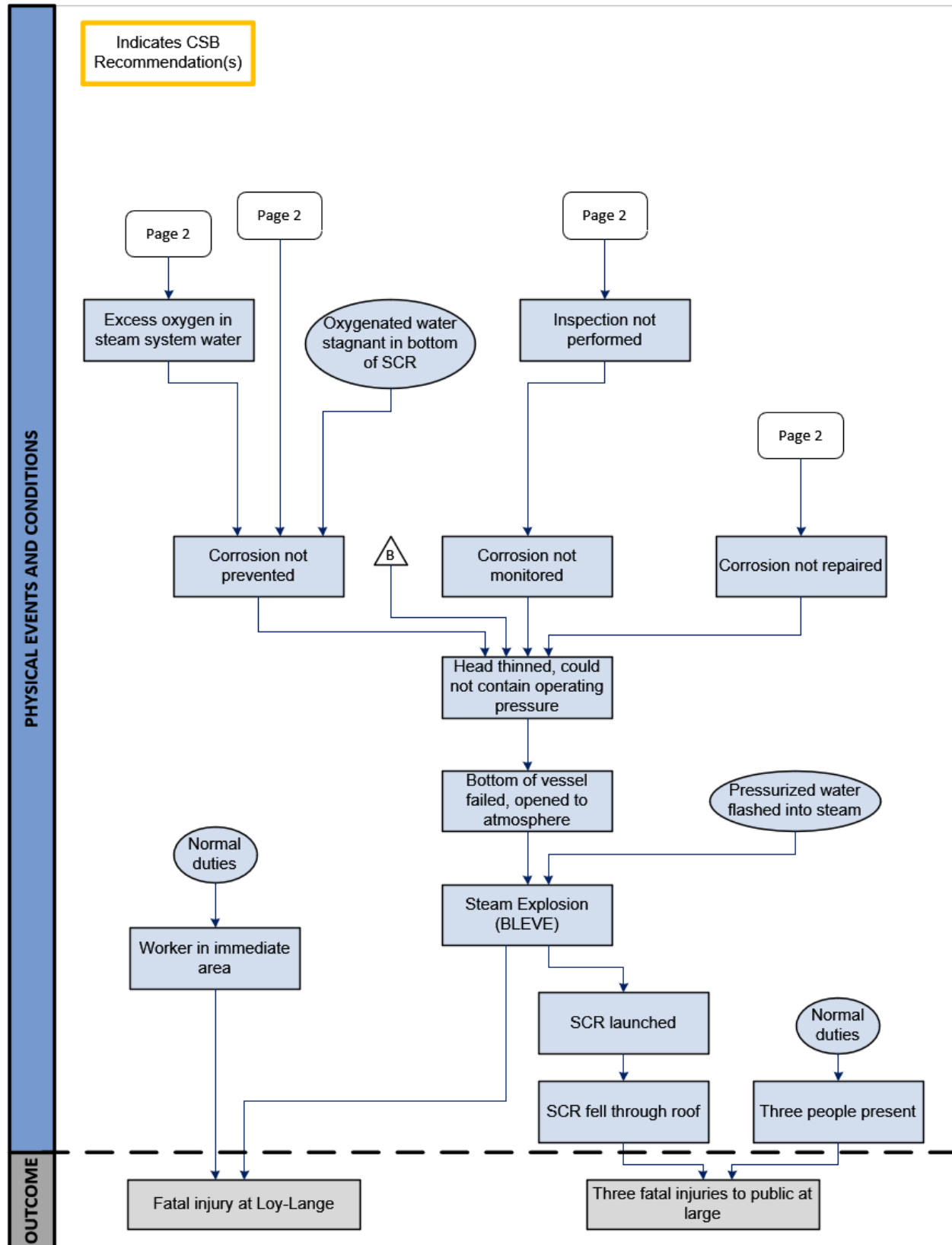



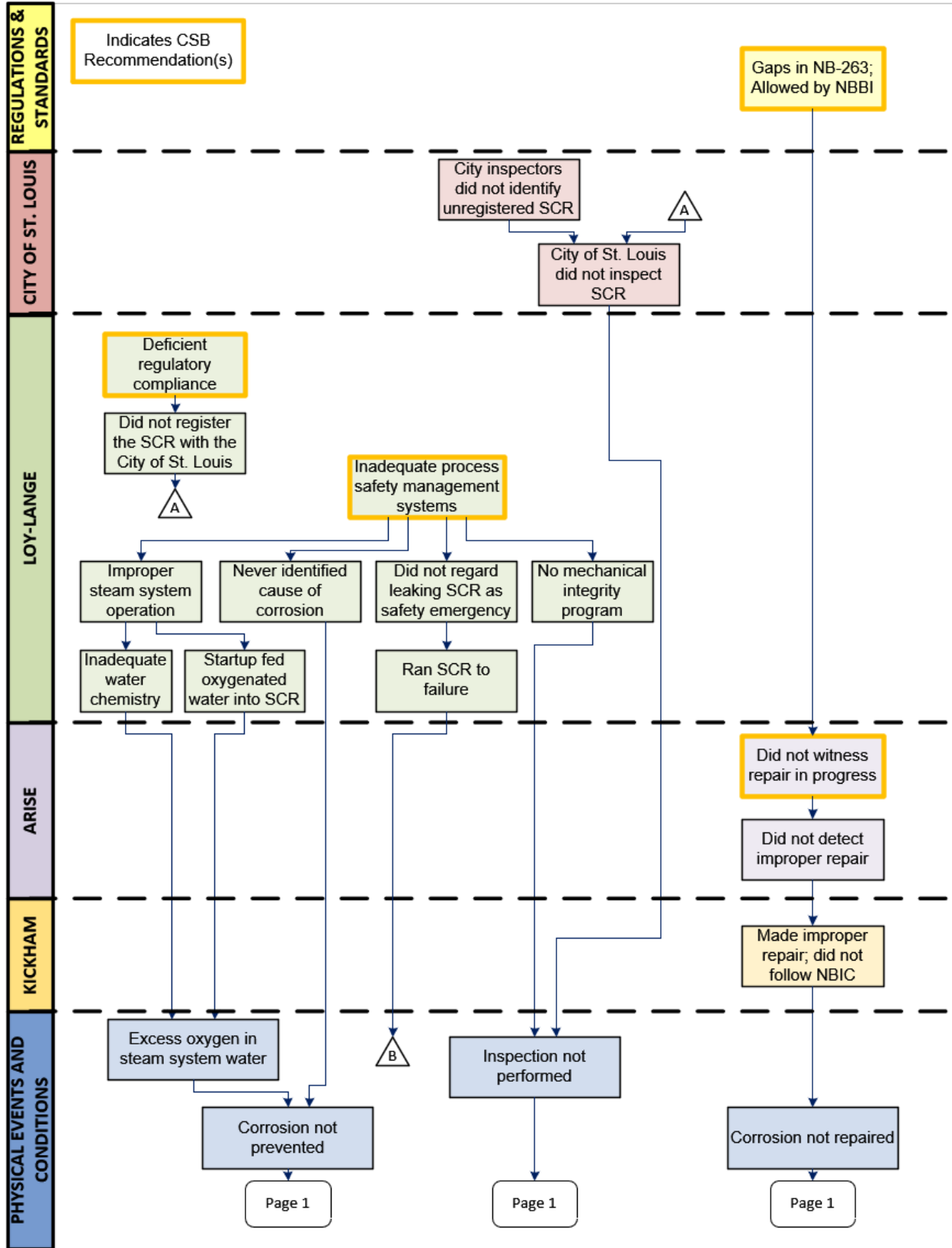

## Appendix B—Steam Plume Analysis

Evidence available to the CSB suggests that a steam system process upset may have occurred during the steam system startup on April 3, 2017. A surveillance video capturing the explosion shows a large plume of steam venting with high velocity from the roof of the building just before the incident (**Figure 36**, top). This steam plume appears substantially larger than the normal plume seen venting from the building historically.

For comparison, using Google Earth® and Google Street View®, the CSB evaluated historical images of the Loy-Lange facility. These images show a small white steam plume emanating from the roof of the facility, which may be from the normal venting of vapor during the deaeration process to remove dissolved gases [31]. One representative photo of the typical steam plume is shown in **Figure 36**.

One of the Loy-Lange stationary engineers confirmed to CSB investigators that the vapor venting from the roof of the facility immediately before the SCR rupture was abnormally large. After seeing the surveillance video, the stationary engineer said:

That was coming off awful hard. That sure looks like it's coming out faster than normal. [...] That's blowing out awful hard. That is much larger than I would have expected from it. [...] Normally, it's like a little wispy cloud [...]



**Figure 36.** Steam plume comparison. (Credit: Top: Kranz; Bottom: Google, edited and annotated by CSB)

FDA, Inc.

As designed by Clayton, the Loy-Lange steam system was equipped with at least six continuous or automatically functioning vents (refer to **Figure 2**):

1. An atmospheric vent line on the make-up tank. This line continuously vented steam, oxygen, and other non-condensable gases from the make-up water.
2. A vent line on the SCR. This line was designed to continuously vent steam, oxygen, and other non-condensable gases from the SCR via an orifice.
3. A device called a backpressure regulator, or BPR, which mechanically regulated the pressure inside the SCR by opening and venting steam whenever the pressure inside the SCR reached the BPR setpoint. This device was designed to open between 100-110 psi.
4. A pressure relief valve designed and installed as the code-required safety device to protect the SCR from unsafe pressure. The relief valve was originally designed to open at 150 psi.
5. A pressure relief valve on the first of the two steam generators, to protect the generator from unsafe pressure (not shown in **Figure 2**). This relief valve was designed with a set pressure of 250 psi.
6. A pressure relief valve on the second of the two steam generators, to protect the generator from unsafe pressure (not shown in **Figure 2**). This relief valve was designed with a set pressure of 250 psi.

The SCR was designed for a maximum operating pressure of 150 psi. However, after the incident, the pressure relief valve installed on the SCR was found to be tagged with a set pressure of 200 psi,<sup>a</sup> 50 psi higher than the SCR design pressure. As a result, this emergency pressure-relief device could not have prevented the pressure in the SCR from exceeding the vessel's design pressure.

Loy-Lange did not have any system to record process data, such as a digital historian capable of storing real-time steam system pressures, temperatures, flow rates, or liquid levels. As a result, the CSB could not definitively determine what the pressure inside the SCR was at the time it ruptured. Loy-Lange also did not have engineering drawings or pictures showing how and where the various atmospheric steam vent lines were installed. The lack of drawings or pictures, as well as the damage to the building, prevented the CSB from definitively determining which of the atmospheric steam vent systems was the source of the steam shown in the surveillance video. However, the abnormally large steam plume just before the SCR ruptured suggests there may have been a high-pressure event in the steam system preceding the explosion.

---

<sup>a</sup> The CSB commissioned testing of the emergency relief valve found installed on the SCR. It functioned as tagged at 200 psi.

## Appendix C—Loy-Lange Personal Safety Program

Loy-Lange produced records and/or descriptions of the following personal safety programs and policies:

- An employee-led safety committee, which was charged with “[identification of] workplace hazards, enforce[ment of] safety rules, measure[ment of] safety performance, reduc[ing] the frequency and severity of injuries, creat[ion of] safety policies as needed, and develop[ment]/monitor[ing of] the safety program;”
- A workplace housekeeping policy;
- A lockout/tagout plan;
- Provision to employees of “appropriate PPE;”
- PPE Hazard Assessment Program;
- Employee training on safety rules and procedures, including “Safety Rules, Drug and Alcohol [rules], Emergency Evacuation Procedures, PPE, a safety video pertaining to overall plant conditions [...] as well as machine specific safety;”
- New employee onboarding which included “OSHA required safety training by reviewing [lockout/tagout], PPE, Hazard Communications (MSDS), Bloodborne Pathogens and Emergency Response/Preparedness;”
- A fork truck operator training and qualification process;
- Arc Flash training for maintenance personnel;
- Certain task-specific procedures and instructions;
- An “internal Quality/Safety Audit” program;
- CPR/First aid training for certain employees and managers;
- Routine safety inspections focusing on “OSHA related issues including but not limited to: electrical compliance, machine guarding, PPE, and job safety analysis”

## Appendix D—Demographic Information for Loy-Lange Surrounding Area

The demographic information of the population residing within about one mile of the Loy-Lange facility is contained below in **Figure 37** and **Table 2**:<sup>a</sup>

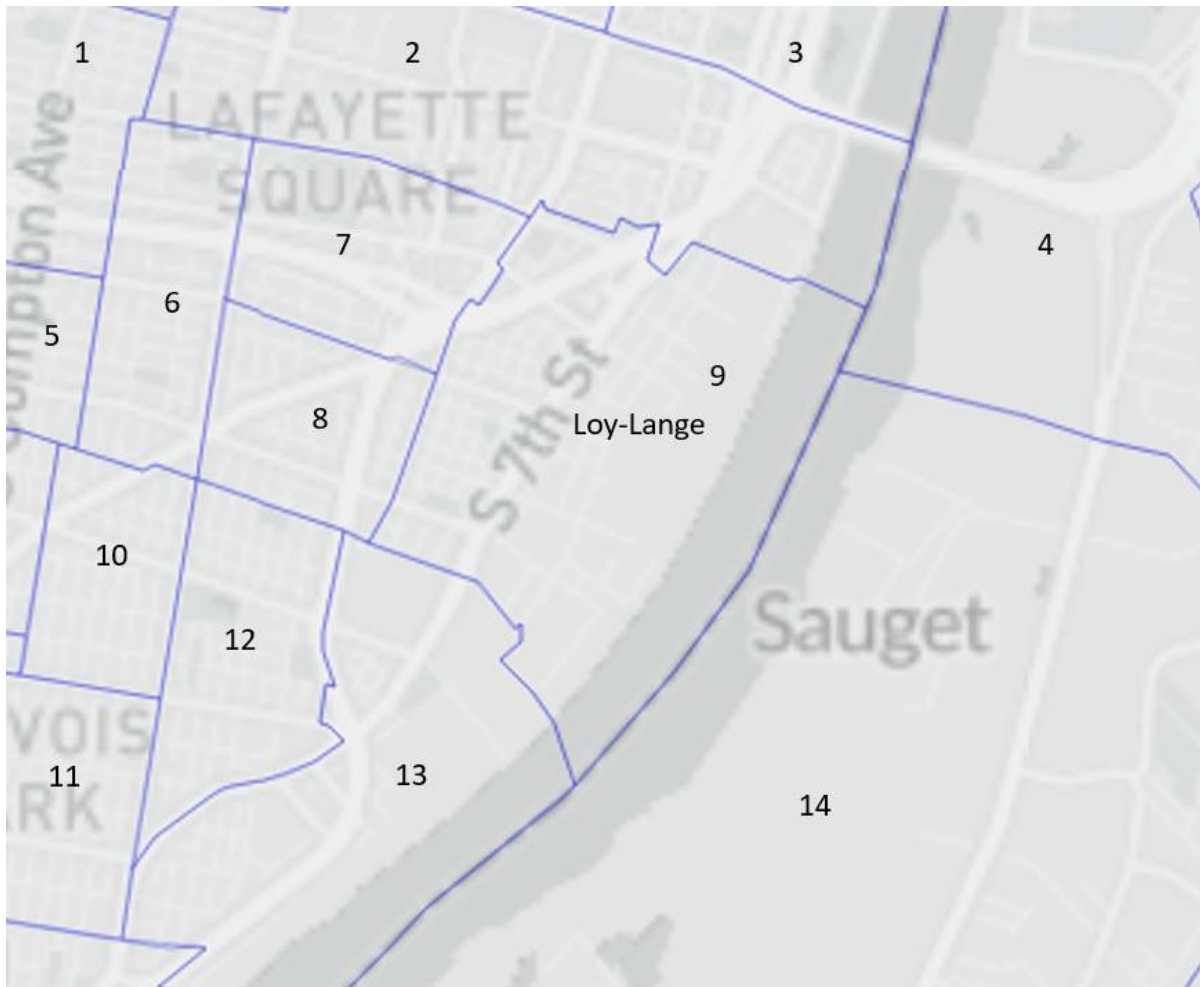

**Figure 37.** Census tracts in the approximately one-mile distance from the Loy-Lange facility. (Credit: Census Reporter, annotated by CSB)

<sup>a</sup> This information was compiled using 2020 Census data as presented by Census Reporter [42]. “Census Reporter is an independent project to make data from the American Community Survey easier to use. [It is] unaffiliated with the U.S. Census Bureau. A News Challenge grant from the Knight Foundation funded the initial build-out of the site. ... Support for [Census Reporter’s] 2020 Decennial Census features was provided by the Google News Initiative. ... [T]he Medill School of Journalism at Northwestern University, home of the Knight Lab, [] provides in-kind support for some of Census Reporter’s ongoing development. Most of [Census Reporter’s] server hosting infrastructure is [] provided by the Oregon State University Open Source Lab [43].”

**Table 2.** Tabulation of Demographic Data for the Populations Within the Census Tracts Shown in **Figure 37.**

Tract Number	Population	Median Age	Race and Ethnicity	Per Capita Income	% Below Poverty Line	Number of Housing Units	Types of Structures
1	4,923	38.0	28% White 61% Black 2% Asian 6% Two+ 4% Hispanic	\$ 35,890	12.8%	1157	42% Single Unit 58% Multi-Unit
2	5,205	29.1	24% White 75% Black <1% Asian <1% Two+ <1% Hispanic	\$ 26,296	25.6%	2369	37% Single Unit 63% Multi-Unit
3	5,438	32.7	49% White 36% Black 1% Native 6% Asian 3% Two+ 5% Hispanic	\$ 56,630	12.2%	3810	4% Single Unit 96% Multi-Unit
4	1,242	43.9	2% White 96% Black 1% Two+	\$ 11,694	27.4%	554	33% Single Unit 63% Multi-Unit 4% Mobile Home
5	4,340	34.0	67% White 24% Black 1% Asian 2% Two+ 5% Hispanic	\$ 46,627	11.6%	2143	47% Single Unit 53% Multi-Unit
6	3,482	36.2	42% White 48% Black 3% Asian 1% Two+ 5% Hispanic	\$ 33,388	19.2%	1932	51% Single Unit 49% Multi-Unit
7	2,782	46.0	72% White 23% Black 1% Asian 2% Two+ 2% Hispanic	\$ 71,283	9.4%	1590	32% Single Unit 68% Multi-Unit
8	2,951	31.5	57% White 39% Black 1% Asian 1% Islander 1% Other 1% Hispanic	\$ 38,253	22.1%	1695	43% Single Unit 56% Multi-Unit 1% Mobile Home
9	2,418	30.7	77% White 15% Black 2% Asian 2% Two+ 3% Hispanic	\$ 52,250	16.1%	1931	27% Single Unit 73% Multi-Unit

10	4,084	34.0	27% White 60% Black 1% Asian 5% Two+ 7% Hispanic	\$ 26,613	25.9%	2152	30% Single Unit 70% Multi-Unit
11	4,190	30.5	31% White 57% Black 1% Other 5% Two+ 6% Hispanic	\$ 16,631	31.2%	2575	43% Single Unit 56% Multi-Unit 1% Mobile Home
12	3,211	35.4	69% White 27% Black 2% Two+ 2% Hispanic	\$ 51,853	8.9%	1694	68% Single Unit 31% Multi-Unit 1% Mobile Home
13	1,848	29.0	22% White 68% Black 2% Other 1% Two+ 7% Hispanic	\$ 14,839	38.6%	921	40% Single Unit 55% Multi-Unit 1% Mobile Home 3% Boat, RV, Van, etc.
14	5,554	33.9	47% White 47% Black 1% Native 2% Asian 1% Other 2% Two+	\$ 18,667	31.0%	2997	81% Single Unit 13% Multi-Unit 5% Mobile Home





**U.S. Chemical Safety and  
Hazard Investigation Board**

**Members of the U.S. Chemical Safety and Hazard Investigation Board:**

Steve Owens  
Interim Executive Authority

Sylvia Johnson, PhD  
Member