



DEPARTMENT OF LABOR & ECONOMIC GROWTH
DIRECTOR'S OFFICE
CONSTRUCTION SAFETY STANDARDS

Filed with the Secretary of State on August 17, 1979 (as amended January 20, 1982) (as amended May 17, 1983)
(as amended May 29, 1985) (as amended September 10, 2002) **(as amended March 14, 2007)**

These rules take effect 14 days after filing with the Secretary of State

(By authority conferred on the director of the department of labor and economic growth by sections 19 and 21 of 1974 PA 154,
and Executive Reorganization Order Nos. 1996-2 and 2003-18, MCL 408.1019, 408.1021, 445.2001, and 445.2011)

R 408.42602, R 408.42605, R 408.42608, R 408.42609, R 408.42616, R 408.42628, R 408.42629, R 408.42634,
R 408.42636, R 408.42648, R 408.42651, and R 408.42655 of the Michigan Administrative Code are amended,
and R 408.42624 and R 408.42625 are rescinded as follows:

Visit our web site at: www.michigan.gov/mioshastandards

PART 26. STEEL ERECTION

TABLE OF CONTENTS

R 408.42601 Scope.....	1	R 408.42634 Open web joists; field-bolted joists.....	7
R 408.42602 Reference of standards.....	3	R 408.42636 Steel joists attachment: erection.....	8
R 408.42604 Definitions; A to C.....	3	R 408.42638 Landing and placing loads.....	10
R 408.42605 Definitions; D to M.....	3	R 408.42640 Installation of metal decking.....	10
R 408.42606 Definitions; O to U.....	4	R 408.42642 Rescinded.....	10
R 408.42608 Site layout, erection plan and construction sequence.....	5	R 408.42643 Systems-engineered metal buildings.....	10
R 408.42609 Hoisting and rigging.....	5	R 408.42644 Falling object protection.....	10
R 408.42610 Multiple lift rigging procedure.....	5	R 408.42645 Fall protection.....	11
R 408.42614 Structural steel assembly.....	6	R 408.42646 Connectors.....	11
R 408.42615 Rescinded.....	6	R 408.42648 Controlled decking zone (CDZ).....	11
R 408.42616 Walking and working surfaces.....	6	R 408.42650 Rescinded.....	11
R 408.42617 Rescinded.....	6	R 408.42651 Criteria for fall protection equipment; custody of fall protection.....	11
R 408.42618 Plumbing-up.....	6	R 408.42653 Training.....	11
R 408.42620 Metal decking and decking bundles.....	6	R 408.42654 Rescinded.....	11
R 408.42621 Rescinded.....	6	R 408.42655 Special training.....	12
R 408.42622 Roof, holes and openings.....	6	R 408.42656 Rescinded.....	12
R 408.42623 Rescinded.....	6		
R 408.42624 Rescinded.....	6	Non-Mandatory Appendixes	
R 408.42625 Rescinded.....	6	Appendix A Site specific erection plan.....	12
R 408.42626 Column anchorage, erection stability, repair, replacement, and anchor rods (anchor bolts).....	7	Appendix B Slip resistance surfaces.....	12
R 408.42628 Beams and columns; diagonal bracing; column splices; perimeter columns.....	7	Appendix C Bridging terminus points.....	13
R 408.42629 Double connections.....	7	Appendix D Controlled decking zones.....	16
R 408.42630 Rescinded.....	7	Appendix E Training.....	16
R 408.42632 Rescinded.....	7	Appendix F Perimeter columns.....	16
		Appendix G Fall protection.....	16
		Appendix H Double connections.....	19

GENERAL PROVISIONS

R 408.42601 Scope.

Rule 2601. (1) This part sets forth requirements to protect employees from the hazards associated with steel erection activities involved in the construction, alteration, or repair of single and multistory buildings, bridges, and other structures where steel erection occurs. The requirements of this part apply to employers engaged in steel erection unless otherwise specified.

This part does not apply to electrical transmission towers, communication and broadcast towers, or tanks. Examples of structures where steel erection may occur, include, but are not limited to, the following:

- (a) Single and multistory buildings.
- (b) Systems-engineered metal buildings.
- (c) Lift slab/tilt-up structures.
- (d) Energy exploration structures.

- (e) Energy production, transfer and storage structures, and facilities.
- (f) Auditoriums.
- (g) Malls.
- (h) Amphitheaters.
- (i) Stadiums.
- (j) Power plants.
- (k) Mills.
- (l) Chemical process structures.
- (m) Bridges.
- (n) Trestles.
- (o) Overpasses.
- (p) Underpasses.
- (q) Viaducts.
- (r) Aqueducts.
- (s) Aerospace facilities and structures.
- (t) Radar and communication structures.
- (u) Light towers.
- (v) Signage.
- (w) Billboards.
- (x) Scoreboards.
- (y) Conveyor systems.
- (z) Conveyor supports and related framing.
- (aa) Stairways.
- (bb) Stair towers.
- (cc) Fire escapes.
- (dd) Draft curtains.
- (ee) Fire containment structures.
- (ff) Monorails.
- (gg) Aerialways.
- (hh) Catwalks.
- (ii) Curtain walls.
- (jj) Window walls.
- (kk) Store fronts.
- (ll) Elevator fronts.
- (mm) Entrances.
- (nn) Skylights.
- (oo) Metal roofs.
- (pp) Industrial structures.
- (qq) Hi-bay structures.
- (rr) Rail, marine, and other transportation structures.
- (ss) Sound barriers.
- (tt) Water process and water containment structures.
- (uu) Air and cable-supported structures.
- (vv) Space frames.
- (ww) Geodesic domes.
- (xx) Canopies.
- (yy) Racks and rack support structures and frames.
- (zz) Platforms.
- (aaa) Walkways.
- (bbb) Balconies.
- (ccc) Atriums.
- (ddd) Penthouses.
- (eee) Car dumpers.
- (fff) Stackers/reclaimers.
- (ggg) Cranes and craneways.
- (hhh) Bins.
- (iii) Hoppers.
- (jjj) Ovens.
- (kkk) Furnaces.
- (lll) Stacks.
- (mmm) Amusement park structures and rides.
- (nnn) Artistic and monumental structures.

- (2)** Steel erection activities include all of the following:
 - (a) Hoisting, laying out, placing, connecting, welding, burning, guying, bracing, bolting, plumbing, and rigging structural steel, steel joists, and metal buildings.
 - (b) Installing metal decking, curtain walls, window walls, siding systems, miscellaneous metals, ornamental iron, and similar materials.
 - (c) Moving point-to-point while performing the activities specified in this subrule.
- (3)** All of the following activities are covered by this part when they occur during and are a part of steel erection activities:
 - (a) Rigging.
 - (b) Hoisting.
 - (c) Laying out.
 - (d) Placing.
 - (e) Connecting.
 - (f) Guying.
 - (g) Bracing.
 - (h) Dismantling.
 - (i) Burning.
 - (j) Welding.
 - (k) Bolting.
 - (l) Grinding.
 - (m) Sealing.
 - (n) Caulking.
 - (o) All related activities for construction, alteration or repair of materials and assemblies such as any of the following:
 - (i) Structural steel.
 - (ii) Ferrous metals and alloys.
 - (iii) Nonferrous metals and alloys.
 - (iv) Glass.
 - (v) Plastics and synthetic composite materials.
 - (vi) Structural metal framing and related bracing and assemblies.
 - (vii) Anchoring devices.
 - (viii) Structural cabling.
 - (ix) Cable stays.
 - (x) Permanent and temporary bents and towers.
 - (xi) Falsework for temporary supports of permanent steel members.
 - (xii) Stone and other non-precast concrete architectural materials mounted on steel frames.
 - (xiii) Safety systems for steel erection.
 - (xiv) Steel and metal joists.
 - (xv) Metal decking and raceway systems and accessories.
 - (xvi) Metal roofing and accessories.
 - (xvii) Metal siding.
 - (xviii) Bridge flooring.
 - (xix) Cold formed steel framing.
 - (xx) Elevator beams.
 - (xxi) Grillage.
 - (xxii) Shelf racks.
 - (xxiii) Multipurpose supports.
 - (xxiv) Crane rails and accessories.
 - (xxv) Miscellaneous, architectural, and ornamental metals and metal work.
 - (xxvi) Ladders.
 - (xxvii) Railings.
 - (xxviii) Handrails.
 - (xxix) Fences and gates.
 - (xxx) Gratings.
 - (xxxi) Trench covers.
 - (xxxii) Floor plates.
 - (xxxiii) Castings.
 - (xxxiv) Sheet metal fabrications.

- (xxxv) Metal panels and panel wall systems.
- (xxxvi) Louvers.
- (xxxvii) Column covers.
- (xxxviii) Enclosures and pockets.
- (xxxix) Stairs.
- (xl) Perforated metals.
- (xli) Ornamental iron work.
- (xlii) Expansion control, including bridge expansion joint assemblies.
- (xliii) Slide bearings
- (xliv) Hydraulic structures.
- (xlv) Fascias.
- (xlvi) Soffit panels.
- (xlvii) Penthouse enclosures.
- (xlviii) Skylights.
- (xlix) Joint fillers.
- (l) Gaskets.
- (li) Sealants and seals.
- (lii) Doors.
- (liii) Windows.
- (liv) Hardware.
- (lv) Detention/security equipment and doors, windows, and hardware.
- (lvi) Conveying systems.
- (lvii) Building specialties.
- (lviii) Building equipment.
- (lix) Machinery and plant equipment, furnishings, and special construction.

(4) The duties of controlling contractors under this part include, but are not limited to, the duties specified in R 408.42608 (1) and (3), R 408.42626 (6), R 408.42644 (2), and R 408.42651 (4).

R 408.42602 Reference of standards.

Rule 2602. (1) The following occupational safety and health administrative standards are referenced in this standard. Up to 5 copies of these standards may be obtained at no charge from the Michigan Department of Labor and Economic Growth, MIOSHA Standards Section, 7150 Harris Drive, P.O. Box 30643, Lansing, Michigan 48909-8143, or via the internet at: www.michigan.gov/mioshastandards. For quantities greater than 5, the cost, at the time of adoption of these rules, is 4 cents per page.

- (a) Construction Safety Standard Part 10. "Lifting and Digging Equipment," being R 408.41001a to R 408.41099a.
- (b) Construction Safety Standard Part 28. "Personnel Hoisting in Steel Erection," being R 408.42801 to R 408.42809.
- (c) Construction Safety Standard Part 45. "Fall Protection," being R 408.44501 to R 408.44502.

R 408.42604 Definitions; A to C.

Rule 2604. (1) "**Anchored bridging**" means that the steel joist bridging is connected to a bridging terminus point.

(2) "**Bolted diagonal bridging**" means diagonal bridging that is bolted to a steel joist or joists.

(3) "**Bridging clip**" means a device that is attached to the steel joist to allow the bolting of the bridging to the steel joist.

(4) "**Bridging terminus point**" means a wall, a beam, tandem joists, with all bridging installed and a horizontal truss in the plane of the top chord, or other element at an end or intermediate point or points of a line of bridging that provides an anchor point for the steel joist bridging.

(5) "**Choker**" means a wire rope or synthetic fiber rigging assembly that is used to attach a load to a hoisting device.

(6) "**Cold forming**" means the process of using press brakes, rolls, or other methods to shape steel into desired cross sections at room temperature.

(7) "**Column**" means a load-carrying vertical member that is part of the primary skeletal framing system. Columns do not include posts.

(8) "**Competent person**" means a person who is experienced and capable of identifying an existing or potential hazard in surroundings, or under working conditions, that are hazardous or dangerous to an employee and who has the authority and knowledge to take prompt corrective measures to eliminate the hazards.

(9) "**Connector**" means an employee who, working with hoisting equipment, is placing and connecting structural members or components.

(10) "**Constructibility**" means the ability to erect structural steel members in accordance with these rules without having to alter the overall structural design.

(11) "**Construction load, for joist erection,**" means any load other than the weight of the employee or employees, the joists, and the bridging bundle.

(12) "**Controlled decking zone (CDZ)**" means an area in which certain work, for example, initial installation and placement of metal decking, may take place without the use of guardrail systems, personal fall arrest systems, fall restraint systems, or safety net systems and in which access to the zone is controlled.

(13) "**Controlled load lowering**" means lowering a load by means of a mechanical hoist drum device that allows a hoisted load to be lowered with maximum control using the gear train or hydraulic components of the hoist mechanism. Controlled load lowering requires the use of the hoist drive motor, rather than the load hoist brake, to lower the load.

(14) "**Controlling contractor**" means a prime contractor, general contractor, construction manager, or any other legal entity that has the overall responsibility for the construction of the project--its planning, quality, and completion.

(15) "**Critical lift**" means a lift that exceeds 75% of the rated capacity of the crane or derrick or that requires the use of more than 1 crane or derrick.

R 408.42605 Definitions; D to M.

Rule 2605. (1) "**Decking hole**" means a gap or void more than 2 inches (5.1 cm) in its least dimension and less than 12 inches (30.5 cm) in its greatest dimension in a floor, roof, or other walking/working surface. Pre-engineered holes in cellular decking for wires, cables, and the like are not included in this definition.

(2) "**Derrick floor**" means an elevated floor of a building or structure that has been designated to receive hoisted pieces of steel before final placement.

(3) "**Double connection**" means an attachment method where the connection point is intended for 2 pieces of steel that share common bolts on either side of a central piece.

(4) "**Double connection seat**" means a structural attachment that, during the installation of a double connection, supports the first member while the second member is connected.

(5) "**Erection bridging**" means the bolted diagonal bridging that is required to be installed before releasing the hoisting cables from the steel joists.

(6) "**Fall restraint system**" means a fall protection system that prevents the user from falling any distance. The system is comprised of either a body belt or body harness, together with an anchorage, connectors, and other necessary equipment. The other components typically include a lanyard, and may also include a lifeline and other devices.

(7) **“Final interior perimeter”** means the perimeter of a large permanent open space within a building such as an atrium or courtyard. This does not include openings for stairways, elevator shafts, and the like.

(8) **“Girt, in systems-engineered metal buildings”** means a “Z” or “C” shaped member formed from sheet steel spanning between primary framing and supporting wall material.

(9) **“Headache ball”** means a solid iron weight, usually spherical, used to keep the loadline taut and positioned above the hook.

(10) **“Hoisting equipment”** means commercially manufactured lifting equipment designed to lift and position a load of known weight to a location at some known elevation and horizontal distance from the equipment’s center of rotation. “Hoisting equipment” includes, but is not limited to, all of the following:

- (a) Cranes.
- (b) Derricks.
- (c) Tower cranes.
- (d) Barge-mounted derricks or cranes.
- (e) Gin poles.
- (f) Gantry hoist systems.

A “come-a-long,” that is, a mechanical device, usually consisting of a chain or cable attached at each end, that is used to facilitate movement of materials through leverage is not considered “hoisting equipment.”

(11) **“Leading edge”** means the unprotected side and edge of a floor, roof, or formwork for a floor or other walking/working surface, such as a deck, which changes location as additional floor, roof, decking, or formwork sections are placed, formed, or constructed.

(12) **“Metal decking”** means a commercially manufactured, structural grade, cold-rolled metal panel formed into a series of parallel ribs. As used in this part, the term includes metal floor and roof decks, standing seam metal roofs, other metal roof systems, and other products, such as bar gratings, checker plate, expanded metal panels, and similar products. After installation and proper fastening, these decking materials serve a combination of functions, including, but not limited to, any of the following:

- (a) A structural element designed in combination with the structure to resist, distribute, and transfer loads, stiffen the structure, and provide a diaphragm action.
- (b) A walking/working surface.
- (c) A form for concrete slabs.
- (d) A support for roofing systems.
- (e) A finished floor or roof.

(13) **“Multiple lift rigging”** means a rigging assembly manufactured by wire rope rigging suppliers that facilitates the attachment of up to 5 independent loads to the hoist rigging of a crane.

R 408.42606 Definitions; O to U.

Rule 2606. (1) “Opening” means a gap or void 12 inches (30.5 cm) or more in its least dimension in a floor, roof, or other walking/working surface. For the purposes of this part, skylights and smoke domes that do not meet the strength requirements of R 408.42622 (4), (5), (6), and (7) shall be regarded as openings.

(2) **“Permanent floor”** means a structurally completed floor at any level or elevation, including slab on grade.

(3) **“Personal fall arrest system”** means a system used to arrest an employee in a fall from a working level. A personal fall arrest system consists of an anchorage, connectors, a body harness, and may include a lanyard, deceleration device, lifeline, or suitable combination of these. The use of a body belt for fall arrest is prohibited.

(4) **“Plumbing up”** means securing to obtain vertical alignment.

(5) **“Positioning device system”** means a body belt or body harness rigged to allow an employee to be supported on an elevated, vertical surface, such as a wall or column, and work with both hands free while leaning.

(6) **“Post”** means a structural member which has a longitudinal axis that is essentially vertical, and which either weighs 300 pounds or less and is axially loaded (a load presses down on the top end) or is not axially loaded, but is laterally restrained by the above member. Posts typically support stair landings, wall framing, mezzanines, and other substructures.

(7) **“Project structural engineer of record”** means the registered, licensed professional who is responsible for the design of structural steel framing and whose seal appears on the structural contract documents.

(8) **“Purlin, in systems-engineered metal buildings,”** means a “Z” or “C” shaped member formed from sheet steel spanning between primary framing and supporting roof material.

(9) **“Qualified person”** means an individual who, by possession of a recognized degree, certificate, or professional standing or by extensive knowledge, training, and experience, has successfully demonstrated the ability to solve or resolve problems relating to the subject matter, the work, or the project.

(10) **“Safety deck attachment”** means an initial attachment that is used to secure an initially placed sheet of decking to keep proper alignment and bearing with structural support members.

(11) **“Shear connector”** means headed steel studs, steel bars, steel lugs, and similar devices that are attached to a structural member for the purpose of achieving composite action with concrete.

(12) **“Steel erection”** means the construction, alteration, or repair of steel buildings, bridges, and other structures, including the installation of metal decking and all planking used during the process of erection.

(13) **“Steel joist”** means an open web, secondary load-carrying member which is 144 feet (43.9 m) or less, which is designed by the manufacturer, and which is used for the support of floors and roofs. This does not include structural steel trusses or cold-formed joists.

(14) **“Steel joist girder”** means an open web, primary load-carrying member which is designed by the manufacturer and which is used for the support of floors and roofs. The term does not include structural steel trusses.

(15) **“Steel truss”** means an open web member designed of structural steel components by the project structural engineer of record. For the purposes of this part, a steel truss is considered equivalent to a solid web structural member.

(16) **“Structural steel”** means a steel member or a member made of a substitute material, such as, but not limited to, fiberglass, aluminum, or composite members. These members include, but are not limited to all of the following that are integrated with the structural steel framing of a building:

- (a) Steel joists.
- (b) Joist girders.
- (c) Purlins.
- (d) Columns.
- (e) Beams.
- (f) Trusses.
- (g) Splices.
- (h) Seats.
- (i) Metal decking.
- (j) Girts.
- (k) Bridging.
- (l) Cold-formed metal framing.

(17) "Systems-engineered metal building" means a metal, field-assembled building system consisting of framing, roof, and wall coverings. Typically, many of these components are cold-formed shapes. These individual parts are fabricated in 1 or more manufacturing facilities and shipped to the jobsite for assembly into the final structure. The engineering design of the system is normally the responsibility of the systems-engineered metal building manufacturer.

(18) "Tank" means a container for holding gases, liquids, or solids.

(19) "Unprotected sides and edges" means any side or edge, except at entrances to points of access, of a walking/working surface, for example, a floor, roof, ramp, or runway, where there is no wall or guardrail system not less than 39 inches (1.0 m) high.

R 408.42608 Site layout, erection plan and construction sequence.

Rule 2608. (1) Before authorizing the commencement of steel erection, the controlling contractor shall ensure that the steel erector is provided with the following written notifications:

- (a) The concrete in the footings, piers, and walls and the mortar in the masonry piers and walls has attained, on the basis of an appropriate ASTM standard test method of field-cured samples, either 75% of the intended minimum compressive design strength or sufficient strength to support the loads imposed during steel erection.
- (b) Any repairs, replacements, and modifications to the anchor bolts were conducted in accordance with R 408.42626(5) and (6).

(2) A steel erection contractor shall not erect steel unless it has received written notification that the concrete in the footings, piers, and walls or the mortar in the masonry piers and walls has attained, on the basis of an appropriate ASTM standard test method of field-cured samples, either 75% of the intended minimum compressive design strength or sufficient strength to support the loads imposed during steel erection.

(3) The controlling contractor shall ensure that both of the following are provided and maintained:

- (a) Adequate access roads into and through the site for the safe delivery and movement of derricks, cranes, trucks, other necessary equipment, and the material to be erected and means and methods for pedestrian and vehicular control. However, this requirement does not apply to roads outside of the construction site.
- (b) A firm, properly graded, drained area which is readily accessible to the work and which has adequate space for the safe storage of materials and the safe operation of the erector's equipment.

(4) All hoisting operations in steel erection shall be preplanned to ensure that the requirements of R 408.42609(4) and (5) are met.

(5) If an employer elects, due to conditions specific to the site, to develop alternate means and methods that provide employee protection in accordance with R 408.42609 (3), R 408.42634 (4), or R 408.42638 (4), then a site-specific erection plan shall be developed by a qualified person and be available at the work site. Guidelines for establishing a site-specific erection plan are contained in appendix A.

R 408.42609 Hoisting and rigging.

Rule 2609. (1) All the provisions of construction safety standard Part 10. "Lifting and Digging Equipment," being R 408.41001a to R 408.41099a, apply to hoisting and rigging.

(2) Personnel hoisting in steel erection is covered by construction safety standard Part 28. "Personnel Hoisting in Steel Erection," being R 408.42801 to R 408.42809.

(3) Safety latches on hooks shall not be deactivated or made inoperable, except in either of the following situations:

- (a) When a qualified rigger has determined that the hoisting and placing of purlins and single joists can be performed more safely by doing so.
- (b) When equivalent protection is provided in a site-specific erection plan.

(4) Routes for suspended loads shall be preplanned to ensure that no employee is required to work directly below a suspended load, except for the following employees:

- (a) Employees engaged in the initial connection of the steel.
- (b) Employees necessary for the hooking or unhooking of the load.

(5) When working under suspended loads, all of the following criteria shall be met:

- (a) Materials being hoisted shall be rigged to prevent unintentional displacement.
- (b) Hooks with self-closing safety latches or their equivalent shall be used to prevent components from slipping out of the hook.
- (c) All loads shall be rigged by a qualified rigger.

R 408.42610 Multiple lift rigging procedure.

Rule 2610. (1) A multiple lift shall only be performed if all of the following criteria are met:

- (a) A multiple lift rigging assembly is used.
- (b) A maximum of 5 members are hoisted per lift.
- (c) Only beams and similar structural members are lifted.
- (d) All employees engaged in the multiple lift have been trained in multiple lift procedures in accordance with R 408.42655(1).
- (e) A crane shall not be used for a multiple lift where such use is contrary to the manufacturer's specifications and limitations.

(2) Components of the multiple lift rigging assembly shall be specifically designed and assembled with a maximum capacity for total assembly and for each individual attachment point. This capacity, certified by the manufacturer or a qualified rigger, shall be based on the manufacturer's specifications with a 5 to 1 safety factor for all components.

(3) The total load shall not exceed either of the following:

- (a) The rated capacity of the hoisting equipment specified in the hoisting equipment load charts.
- (b) The rigging capacity specified in the rigging rating chart.

(4) The multiple lift rigging assembly shall be rigged with members attached at their center of gravity and maintained reasonably level, rigged from top down, and rigged not less than 7 feet (2.1 m) apart.

(5) The members on the multiple lift rigging assembly shall be set from the bottom up.

(6) Controlled load lowering shall be used whenever the load is over the connectors.

R 408.42614 Structural steel assembly.

Rule 2614. (1) Structural stability shall be maintained at all times during the erection process.

(2) All of the following additional requirements shall apply for multistory structures:

- (a) The permanent floors shall be installed as the erection of structural members progresses, and there shall be not more than 8 stories between the erection floor and the uppermost permanent floor, except where the structural integrity is maintained as a result of the design.
- (b) There shall not be more than 4 floors or 48 feet (14.6 m), whichever is less, of unfinished bolting or welding above the foundation or uppermost permanently secured floor, except where the structural integrity is maintained as a result of the design.
- (c) A fully planked or decked floor or nets shall be maintained within 2 stories or 30 feet (9.1 m), whichever is less, directly under any erection work being performed.

R 408.42615 Rescinded.**R 408.42616 Walking and working surfaces.**

Rule 2616. (1) Shear connectors, such as headed steel studs, steel bars, or steel lugs, reinforcing bars, deformed anchors, or threaded studs shall not be attached to the top flanges of beams, joists, or beam attachments so that they project vertically from or horizontally across the top flange of the member until after the metal decking or other walking/working surface has been installed.

(2) If shear connectors are used in the construction of composite floors, roofs, and bridge decks, then employees shall lay out and install the shear connectors after the metal decking has been installed, using the metal decking as a working platform. Shear connectors shall not be installed from within a controlled decking zone (CDZ), as specified in R 408.42648(1)(g).

(3) Slip resistance of skeletal structural steel. Workers shall not be permitted to walk the top surface of any structural steel member installed after July 18, 2006, that has been coated with paint or similar material, unless documentation or certification that the coating has achieved a minimum average slip resistance of .50 when measured with an English XL tribometer or equivalent tester on a wetted surface at a testing laboratory is provided. Such documentation or certification shall be based on the appropriate ASTM standard test method conducted by a laboratory capable of performing the test. The results shall be available at the site and to the steel erector. Appendix B references appropriate ASTM standard test methods that may be used to comply with this subrule.

R 408.42617 Rescinded.**R 408.42618 Plumbing-up.**

Rule 2618. (1) Turnbuckles and other apparatus used in plumbing up shall be accessible to the employees for adjustment and dismantling. Connections of the equipment used in plumbing up shall be secured. The turnbuckles shall be secured to prevent unwinding while under stress.

(2) When deemed necessary by a competent person, plumbing-up equipment shall be installed in conjunction with the steel erection process to ensure the stability of the structure.

(3) When used, plumbing-up equipment shall be in place and properly installed before the structure is loaded with construction material such as loads of joists, bundles of decking, or bundles of bridging.

(4) Plumbing-up equipment shall be removed only with the approval of a competent person.

R 408.42620 Metal decking and decking bundles.

Rule 2620. (1) Bundle packaging and strapping shall not be used for hoisting unless specifically designed for that purpose.

(2) If loose items such as dunnage, flashing, or other materials are placed on the top of metal decking bundles to be hoisted, such items shall be secured to the bundles.

(3) Bundles of metal decking on joists shall be landed in accordance with R 408.42638(4).

(4) Metal decking bundles shall be landed on framing members so that enough support is provided to allow the bundles to be unbanded without dislodging the bundles from the supports.

(5) At the end of the shift or when environmental or jobsite conditions require, metal decking shall be secured against displacement.

R 408.42621 Rescinded.**R 408.42622 Roof, holes and openings.**

Rule 2622. (1) Framed metal deck openings shall have structural members turned down to allow continuous deck installation, except where not allowed by structural design constraints or constructibility.

(2) Roof and floor holes and openings shall be decked over. If hole or opening size, configuration, or other structural design does not allow openings to be decked over, such as with elevator shafts, stair wells, and the like, then employees shall be protected in accordance with R 408.42645(1).

(3) Metal decking holes and openings shall not be cut until immediately before being permanently filled with the equipment or structure needed or intended to fulfill its specific use and which meets the strength requirements of R 408.42622 (4), (5), (6), and (7) or shall be immediately covered.

(4) Covers for roof and floor openings shall be capable of supporting, without failure, twice the weight of the employees, equipment, and materials that may be imposed on the cover at any one time.

(5) All covers shall be secured when installed to prevent accidental displacement by the wind, equipment, or employees.

(6) All covers shall be painted with high-visibility paint or shall be marked with the word "hole" or "cover" to provide warning of the hazard.

(7) Smoke dome or skylight fixtures that have been installed are not considered covers for the purpose of this rule unless they meet the strength requirements of subrule (4) of this rule.

(8) Decking gaps around columns. Wire mesh, exterior plywood, or the equivalent, shall be installed around columns where planks or metal decking do not fit tightly. The materials used shall be of sufficient strength to provide fall protection for personnel and prevent objects from falling through.

R 408.42623 Rescinded.**R 408.42624 Rescinded.****R 408.42625 Rescinded.**

R 408.42626 Column anchorage, erection stability, repair, replacement, and anchor rods (anchor bolts).

Rule 2626. (1) All columns shall be anchored by a minimum of 4 anchor rods (anchor bolts).

(2) Each column anchor rod (anchor bolt) assembly, including the column-to-base plate weld and the column foundation, shall be designed to resist a minimum eccentric gravity load of 300 pounds (136.2 kg) located 18 inches (.46 m) from the extreme outer face of the column in each direction at the top of the column shaft.

(3) Columns shall be set on level finished floors, pre-grouted leveling plates, leveling nuts, or shim packs that are adequate to transfer the construction loads.

(4) All columns shall be evaluated by a competent person to determine whether guying or bracing is needed; if guying or bracing is needed, then it shall be installed.

(5) Anchor rods (anchor bolts) shall not be repaired, replaced, or field-modified without the approval of the project structural engineer of record.

(6) Before the erection of a column, the controlling contractor shall provide written notification to the steel erector if there has been any repair, replacement, or modification of the anchor rods (anchor bolts) of that column.

R 408.42628 Beams and columns; diagonal bracing; column splices; perimeter columns.

Rule 2628. (1) During the final placing of solid web structural members, the load shall not be released from the hoisting line until the members are secured with not less than 2 bolts per connection, of the same size and strength as shown in the erection drawings, drawn up wrench-tight or the equivalent as specified by the project structural engineer of record, except as specified in subrule (3) of this rule.

(2) A competent person shall determine if more than 2 bolts are necessary to ensure the stability of cantilevered members; if additional bolts are needed, they shall be installed.

(3) Solid web structural members used as diagonal bracing shall be secured by at least 1 bolt per connection drawn up wrench-tight or the equivalent as specified by the project structural engineer of record.

(4) Each column splice shall be designed to resist a minimum eccentric gravity load of 300 pounds (136.2 kg) located 18 inches (.46 m) from the extreme outer face of the column in each direction at the top of the column shaft.

(5) Perimeter columns shall not be erected unless both of the following provisions are satisfied:

- (a) The perimeter columns extend a minimum of 48 inches (1.2 m) above the finished floor to permit installation of perimeter safety cables before erection of the next tier, except where constructibility does not allow. (See appendix F)
- (b) The perimeter columns have holes or other devices in or attached to perimeter columns at 42 to 45 inches (107-114 cm) above the finished floor and the midpoint between the finished floor and the top cable to permit installation of perimeter safety cables required by R 408.42645(2), except where constructibility does not allow. (See appendix F)

R 408.42629 Double connections.

Rule 2629. (1) If 2 structural members on opposite sides of a column web, or a beam web over a column, are connected sharing common connection holes, then at least 1 bolt with its wrench-tight nut shall remain connected to the first member unless a shop-attached or field-attached seat or equivalent connection device is supplied with the member to secure the first member and prevent the column from being displaced (see appendix H for examples of equivalent connection devices).

(2) If a seat or equivalent device is used, then the seat (or device) shall be designed to support the load during the double connection process. The seat or equivalent device shall be adequately bolted or welded to both a supporting member and the first member before the nuts on the shared bolts are removed to make the double connection.

R 408.42630 Rescinded.

R 408.42632 Rescinded.

R 408.42634 Open web joists; field-bolted joists.

Rule 2634. (1) Except as provided in subrule (2) of this rule, where steel joists are used and columns are not framed in at least 2 directions with solid web structural steel members, a steel joist shall be field-bolted at the column to provide lateral stability to the column during erection. For the installation of this joist, all of the following provisions apply:

- (a) A vertical stabilizer plate shall be provided on each column for steel joists. The plate shall be a minimum of 6 inches by 6 inches (152 mm by 152 mm) and shall extend not less than 3 inches (76 mm) below the bottom chord of the joist with a 13/16-inch (21 mm) hole to provide an attachment point for guying or plumbing cables.
- (b) The bottom chords of steel joists at columns shall be stabilized to prevent rotation during erection.
- (c) Hoisting cables shall not be released until the seat at each end of the steel joist is field-bolted, and each end of the bottom chord is restrained by the column stabilizer plate.
- (2) If constructibility does not allow a steel joist to be installed at the column, then both of the following provisions apply:
 - (a) An alternate means of stabilizing joists shall be installed on both sides near the column and the alternate means shall satisfy all of the following provisions:
 - (i) Provide stability equivalent to subrule (1) of this rule.
 - (ii) Be designed by a qualified person.
 - (iii) Be shop-installed.
 - (iv) Be included in the erection drawings.
 - (b) Hoisting cables shall not be released until the seat at each end of the steel joist is field-bolted and the joist is stabilized.
- (3) If steel joists at or near columns span 60 feet (18.3 m) or less, then the joist shall be designed with sufficient strength to allow 1 employee to release the hoisting cable without the need for erection bridging.
- (4) If steel joists at or near columns span more than 60 feet (18.3 m), then the joists shall be set in tandem with all bridging installed, unless an alternative method of erection, which provides equivalent stability to the steel joist, is designed by a qualified person and is included in the site-specific erection plan.
- (5) A steel joist or steel joist girder shall not be placed on any support structure unless the structure is stabilized.
- (6) If steel joists are landed on a structure, then they shall be secured to prevent unintentional displacement before installation.

(7) A modification that affects the strength of a steel joist or steel joist girder shall not be made without the approval of the project structural engineer of record.

(8) Both of the following provisions apply to field-bolted joists:

(a) Except for steel joists that have been preassembled into panels, connections of individual steel joists to steel structures in bays of 40 feet (12.2 m) or more shall be fabricated to allow for field-bolting during erection.

(b) The connections specified in subdivision (a) of this subrule shall be field-bolted unless constructibility does not allow.

(9) Steel joists and steel joist girders shall not be used as anchorage points for a fall arrest system unless written approval to do so is obtained from a qualified person.

(10) A bridging terminus point shall be established before bridging is installed. (See appendix C)

R 408.42636 Steel joists attachment: erection.

Rule 2636. (1) Each end of "K" series steel joists shall be attached to the support structure with a minimum of 2 1/8-inch (3 mm) fillet welds 1 inch (25 mm) long or with 2 1/2-inch (13 mm) bolts, or the equivalent.

(2) Each end of "LH" and "DLH" series steel joists and steel joist girders shall be attached to the support structure with a minimum of 2 1/4-inch (6 mm) fillet welds 2 inches (51 mm) long, or with 2 3/4-inch (19 mm) bolts, or the equivalent.

(3) Except as provided in subrule (4) of this rule, each steel joist shall be attached to the support structure, at least at 1 end on both sides of the seat, immediately upon placement in the final erection position and before additional joists are placed.

(4) Panels that have been preassembled from steel joists with bridging shall be attached to the structure at each corner before the hoisting cables are released.

(5) Both sides of the seat of 1 end of each steel joist that requires bridging under tables A and B shall be attached to the support structure before hoisting cables are released.

(6) For joists that are more than 60 feet long, both ends of the joist shall be attached as specified in this rule before the hoisting cables are released.

(7) On steel joists that do not require erection bridging under tables A and B, only 1 employee shall be allowed on the joist until all bridging is installed and anchored. Tables A and B read as follows:

TABLE A
ERECTION BRIDGING FOR SHORT SPAN JOISTS

Joist	Span		Joist	Span		Joist	Span		Joist	Span		Joist	Span
8L1	NM		18K9	NM		24K9	44-0		30K12	54-0		20KCS5	NM
10K1	NM		18K10	NM		24K10	NM		10KCS1	NM		22KCS2	36-0
12K1	23-0		20K3	32-0		24K12	NM		10KCS2	NM		22KCS3	40-0
12K3	NM		20K4	34-0		26K5	38-0		10KCS3	NM		22KCS4	NM
12K5	NM		20K5	34-0		26K6	39-0		12KCS1	NM		22KCS5	NM
14K1	27-0		20K6	36-0		26K7	43-0		12KCS2	NM		24KCS2	39-0
14K3	NM		20K7	39-0		26K8	44-0		12KCS3	NM		24KCS3	44-0
14K4	NM		20K9	39-0		26K9	45-0		14KCS1	NM		24KCS4	NM
14K6	NM		20K10	NM		26K10	49-0		14KCS2	NM		24KCS5	NM
16K2	29-0		22K4	34-0		26K12	NM		14KCS3	NM		26KCS2	39-0
16K3	30-0		22K5	35-0		28K6	40-0		16KCS2	NM		26KCS3	44-0
16K4	32-0		22K6	36-0		28K7	43-0		16KCS3	NM		26KCS4	NM
16K5	32-0		22K7	40-0		28K8	44-0		16KCS4	NM		26KCS5	NM
16K6	NM		22K9	40-0		28K9	45-0		16KCS5	NM		28KCS2	40-0
16K7	NM		22K10	40-0		28K10	49-0		18KCS2	35-0		28KCS3	45-0
16K9	NM		22K11	40-0		28K12	53-0		18KCS3	NM		28KCS4	53-0
18K3	31-0		24K4	36-0		30K7	44-0		18KCS4	NM		28KCS5	53-0
18K4	32-0		24K5	38-0		30K8	45-0		18KCS5	NM		30KCS3	45-0
18K5	33-0		24K6	39-0		30K9	45-0		20KCS2	36-0		30KCS4	54-0
18K6	35-0		24K7	43-0		30K10	50-0		20KCS3	39-0		30KCS5	54-0
18K7	NM		24K8	43-0		30K11	52-0		20KCS4	NM			

NM = Not Mandatory

TABLE B

ERECTION BRIDGING FOR LONG SPAN JOISTS

Joist	Span		Joist	Span		Joist	Span
18LH02	33-0		24LH03	35-0		32LH06	47-0 through 60-0
18LH03	NM		24LH04	39-0		32LH07	47-0 through 60-0
18LH04	NM		24LH05	40-0		32LH08	55-0 through 60-0
18LH05	NM		24LH06	45-0		32LH09	NM through 60-0
18LH06	NM		24LH07	NM		32LH10	NM through 60-0
18LH07	NM		24LH08	NM		32LH11	NM through 60-0
18LH08	NM		24LH09	NM		32LH12	NM through 60-0
18LH09	NM		24LH10	NM		32LH13	NM through 60-0
20LH02	33-0		24LH11	NM		32LH14	NM through 60-0
20LH03	38-0		28LH05	42-0		32LH15	NM through 60-0
20LH04	NM		28LH06	42-0		36LH07	47-0 through 60-0
20LH05	NM		28LH07	NM		36LH08	47-0 through 60-0
20LH06	NM		28LH08	NM		36LH09	57-0 through 60-0
20LH07	NM		28LH09	NM		36LH10	NM through 60-0
20LH08	NM		28LH10	NM		36LH11	NM through 60-0
20LH09	NM		28LH11	NM		36LH12	NM through 60-0
20LH10	NM		28LH12	NM		36LH13	NM through 60-0
			28LH13	NM		36LH14	NM through 60-0
						36LH15	NM through 60-0

NM = Not Mandatory

(8) Employees shall not be allowed on steel joists where the span of the steel joist is equal to or greater than the span shown in tables A and B, except in accordance with subrules (10), (11), (12), (13), (14), and (15) of this rule.

(9) When permanent bridging terminus points cannot be used during erection, additional temporary bridging terminus points are required to provide stability. (See appendix C)

(10) If the span of the steel joist is equal to or greater than the span shown in tables A and B, then all of the following provisions shall apply:

- (a) A row of bolted diagonal erection bridging shall be installed near the midspan of the steel joist.
- (b) Hoisting cables shall not be released until the bolted diagonal erection bridging specified in subdivision (a) of this subrule is installed and anchored.
- (c) Not more than 1 employee shall be allowed on spans of steel joist that is equal to or greater than the span shown in tables A and B, until all other bridging is installed and anchored.

(11) If the span of the steel joist is not less than 60 feet (18.3 m) and not more than 100 feet (30.5 m), then all of the following provisions shall apply:

- (a) All rows of bridging shall be bolted diagonal bridging.
- (b) Two rows of bolted diagonal erection bridging shall be installed near the third points of the steel joist.
- (c) Hoisting cables shall not be released until bolted diagonal erection bridging is installed and anchored.

(d) Not more than 2 employees shall be allowed on spans of steel joist not less than 60 feet and not more than 100 feet until all other bridging is installed and anchored.

(12) If the span of the steel joist is not less than 100 feet (30.5 m) and not more than 144 feet (43.9 m), then all of the following provisions shall apply:

- (a) All rows of bridging shall be bolted diagonal bridging.
- (b) Hoisting cables shall not be released until all bridging is installed and anchored.
- (c) Not more than 2 employees shall be allowed on spans of steel joist that are not less than 100 feet and not more than 144 feet until all bridging is installed and anchored.

(13) For steel members spanning more than 144 feet (43.9 m), the erection methods used shall be in accordance with R 408.42628 and R 408.42629.

(14) If any steel joist specified in subrules (6), (10), (11), and (12) of this rule is a bottom chord bearing joist, then a row of bolted diagonal bridging shall be provided near the supports. The bridging shall be installed and anchored before the hoisting cables are released.

(15) If bolted diagonal erection bridging is required by this rule, then all of the following provisions shall apply:

- (a) The bridging shall be indicated on the erection drawing.
- (b) The erection drawing shall be the exclusive indicator of the proper placement of the bridging.
- (c) Shop-installed bridging clips, or functional equivalents, shall be used where the bridging bolts to the steel joists.
- (d) If 2 pieces of bridging are attached to the steel joist by a common bolt, then the nut that secures the first piece of bridging shall not be removed from the bolt for the attachment of the second.
- (e) Bridging attachments shall not protrude above the top chord of the steel joist.

R 408.42638 Landing and placing loads.

Rule 2638. (1) During the construction period, an employer placing a load on steel joists shall ensure that the load is distributed so as not to exceed the carrying capacity of any steel joist.

(2) Except for subrule (4) of this rule, a construction load is not allowed on the steel joists until all bridging is installed and anchored and all joist-bearing ends are attached.

(3) The weight of a bundle of joist bridging is not more than a total of 1,000 pounds (454 kg). A bundle of joist bridging shall be placed on a minimum of 3 steel joists that are secured at 1 end. The edge of the bridging bundle shall be positioned within 1 foot (.30 m) of the secured end.

(4) A bundle of decking shall not be placed on steel joists until all bridging has been installed and anchored and all joist bearing ends attached, unless all of the following conditions are met:

- (a) The employer has first determined from a qualified person and documented in a site-specific erection plan that the structure or portion of the structure is capable of supporting the load.
 - (b) The bundle of decking is placed on a minimum of 3 steel joists.
 - (c) The joists supporting the bundle of decking are attached at both ends.
 - (d) At least 1 row of bridging is installed and anchored.
 - (e) The total weight of the bundle of decking is not more than 4,000 pounds (1816 kg).
 - (f) Placement of the bundle of decking shall be in accordance with subrule (5) of this rule.
- (5)** The edge of the construction load shall be placed within 1 foot (.30 m) of the bearing surface of the joist end.

R 408.42640 Installation of metal decking.

Rule 2640. (1) Except as provided in R 408.42648(1), metal decking shall be laid tightly and immediately secured upon placement to prevent accidental movement or displacement.

(2) During initial placement, metal decking panels shall be placed to ensure full support by structural members.

(3) Derrick floors. A derrick floor shall be fully decked or planked and the steel member connections completed to support the intended floor loading.

(4) Temporary loads placed on a derrick floor shall be distributed over the underlying support members so as to prevent local overloading of the deck material.

(5) Temporary flooring shall comply with all of the following provisions:

- (a) Consist of either wood planking which is not less than 2 inches thick, undressed, full size or metal decking or grating of equivalent strength.
 - (b) Cover the entire area, except for access openings.
 - (c) Be secured against displacement.
 - (d) Be capable of carrying the maximum intended working load.
- (6)** Planking of temporary floors shall comply with both of the following provisions:
- (a) Extend beyond an end bearer not less than 6 inches nor more than 12 inches.

- (b) Overlap any intermediate bearer by a minimum of 12 inches. (See figure 1.) Figure 1 reads as follows:

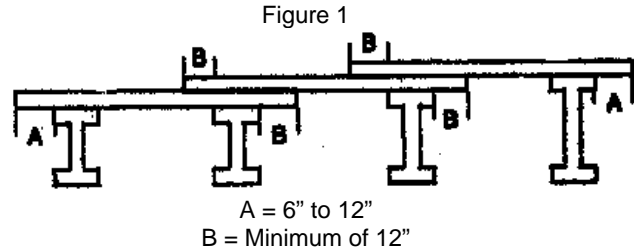

(7) When gathering and stacking temporary floor planks, the planks shall be removed successively, working toward the last panel of the temporary floor so that the work is always done from the planked floor.

(8) When gathering and stacking temporary floor planks from the last panel, employees assigned to such work shall be protected as specified in R 408.42645.

R 408.42642 Rescinded.**R 408.42643 Systems-engineered metal buildings.**

Rule 2643. (1) All of the requirements of this part apply to the erection of systems-engineered metal buildings, except for R 408.42626, R 408.42634, R 408.42636, and R 408.42638.

(2) Each structural column shall be anchored by a minimum of 4 anchor rods (anchor bolts).

(3) Rigid frames shall have 50% of their bolts or the number of bolts specified by the manufacturer, whichever is greater, installed and tightened on both sides of the web adjacent to each flange before the hoisting equipment is released.

(4) Construction loads shall not be placed on any structural steel framework unless the framework is safely bolted, welded, or otherwise adequately secured.

(5) In girt and eave strut-to-frame connections, when girts or eave struts share common connection holes, at least 1 bolt with its wrench-tight nut shall remain connected to the first member unless a manufacturer-supplied, field-attached seat or similar connection device is present to secure the first member so that the girt or eave strut is always secured against displacement.

(6) Both ends of all steel joists or cold-formed joists shall be fully bolted or welded to the support structure before any of the following:

- (a) Releasing the hoisting cables.
- (b) Allowing an employee on the joists.
- (c) Allowing any construction loads on the joists.

(7) Purlins and girts shall not be used as an anchorage point for a fall arrest system unless written approval is obtained from a qualified person.

(8) Purlins may only be used as a walking/working surface when installing safety systems, after all permanent bridging has been installed and fall protection is provided.

(9) Construction loads may be placed only within a zone that is within 8 feet (2.5 m) of the centerline of the primary support member.

R 408.42644 Falling object protection.

Rule 2644. (1) Securing loose items aloft. All materials, equipment, and tools that are not in use while aloft shall be secured against accidental displacement.

(2) Protection from falling objects other than materials being hoisted. The controlling contractor shall bar other construction processes below steel erection unless overhead protection for the employees below is provided.

(3) A container shall be provided for storing and carrying fasteners, such as bolts and rivets and drift pins. The container shall be secured against inadvertent displacement when there is a possibility of the container falling.

(4) If a bolt, drift pin, or rivet is knocked out, then a means shall be provided to prevent it from falling.

(5) Riveting shall not be done in the vicinity of combustible material unless precautions are taken to prevent fire.

R 408.42645 Fall protection.

Rule 2645. (1) Except as provided by subrule (3) of this rule, each employee engaged in a steel erection activity who is on a walking/working surface with an unprotected side or edge more than 15 feet (4.6 m) above a lower level shall be protected from fall hazards by guardrail systems, safety net systems, personal fall arrest systems, positioning device systems, or fall restraint systems.

(2) Perimeter safety cables. On multistory structures, perimeter safety cables shall be installed at the final interior and exterior perimeters of the floors as soon as the metal decking has been installed.

(3) Connectors and employees working in controlled decking zones shall be protected from fall hazards as provided in R 408.42646 and R 408.42648.

R 408.42646 Connectors.

Rule 2646. (1) Each connector shall be in compliance with all of the following provisions:

- (a) Be protected in accordance with R 408.42645(1) from fall hazards of more than 2 stories or 30 feet (9.1 m) above a lower level, whichever is less.
- (b) Have completed connector training in accordance with R 408.42655(2).
- (c) Be provided, at heights of more than 15 and up to 30 feet above a lower level, with a personal fall arrest system, positioning device system, or fall restraint system and wear the equipment necessary to be able to be tied off; or be provided with other means of protection from fall hazards in accordance with R 408.42645(1).

R 408.42648 Controlled decking zone (CDZ).

Rule 2648. (1) A controlled decking zone may be established in that area of the structure of more than 15 and up to 30 feet above a lower level where metal decking is initially being installed and forms the leading edge of a work area. In each CDZ, all of the following provisions shall apply:

- (a) Each employee working at the leading edge in a CDZ shall be protected from fall hazards of more than 2 stories or 30 feet (9.1 m), whichever is less.
- (b) Access to a CDZ shall be limited to only those employees engaged in leading edge work.
- (c) The boundaries of a CDZ shall be designated and clearly marked. The CDZ shall not be more than 90 feet (27.4 m) wide and 90 (27.4 m) feet deep from any leading edge. The CDZ shall be marked by the use of control lines or the equivalent. Examples of acceptable procedures for demarcating CDZs can be found in appendix D.

- (d) Each employee working in a CDZ shall have completed CDZ training in accordance with R 408.42655(3).
- (e) Unsecured decking in a CDZ shall not be more than 3,000 square feet (914.4 m²).
- (f) Safety deck attachments shall be performed in the CDZ from the leading edge back to the control line and shall have not less than 2 attachments for each metal decking panel.
- (g) Final deck attachments and installation of shear connectors shall not be performed in the CDZ.

R 408.42650 Rescinded.

R 408.42651 Criteria for fall protection equipment; custody of fall protection.

Rule 2651. (1) Guardrail systems, safety net systems, personal fall arrest systems, positioning device systems and their components shall conform to the criteria in 29 C.F.R. §1926.502, which is adopted by reference in R 408.44502 of construction safety standard Part 45. "Fall Protection," being R 408.44501to R 408.44502. (See appendix G)

(2) Fall arrest system components shall be used in fall restraint systems and shall conform to the criteria in 29 C.F.R. §1926.502, which is adopted by reference in R 408.44502 of construction safety standard Part 45. "Fall Protection," being R 408.44501to R 408.44502. (See appendix G) Either body belts or body harnesses shall be used in fall restraint systems.

(3) Perimeter safety cables shall meet the criteria for guardrail systems in 29 C.F.R. §1926.502, which is adopted by reference in R 408.44502 of construction safety standard Part 45. "Fall Protection," being R 408.44501to R 408.44502. (See appendix G)

(4) Fall protection provided by the steel erector shall remain in the area where steel erection activity has been completed, to be used by other trades, only if the controlling contractor or its authorized representative has done both of the following:

- (a) Directed the steel erector to leave the fall protection in place.
- (b) Inspected and accepted control and responsibility of the fall protection before authorizing persons other than steel erectors to work in the area.

R 408.42653 Training.

Rule 2653. (1) Training personnel. Training required by this rule shall be provided by a qualified person or persons.

(2) An employer shall provide a training program for all employees exposed to fall hazards. The program shall include training and instruction in all of the following areas:

- (a) The recognition and identification of fall hazards in the work area.
- (b) The use and operation of all of the following:
 - (i) Guardrail systems, including perimeter safety cable systems.
 - (ii) Personal fall arrest systems.
 - (iii) Positioning device systems.
 - (iv) Fall restraint systems.
 - (v) Safety net systems.
 - (vi) Other protection to be used.
- (c) The correct procedures for erecting, maintaining, disassembling, and inspecting the fall protection systems to be used.
- (d) The procedures to be followed to prevent falls to lower levels and through or into holes and openings in walking/working surfaces and walls.
- (e) The fall protection requirements of this part.

R 408.42654 Rescinded.

R 408.42655 Special training.

Rule 2655. (1) An employer shall ensure that each employee who performs multiple lift rigging has been provided training in both of the following areas:

- (a) The nature of the hazards associated with multiple lifts.
- (b) The proper procedures and equipment to perform multiple lifts required by R 408.42610.

(2) An employer shall ensure that each connector has been provided training in the following areas:

- (a) The nature of the hazards associated with connecting.
- (b) The establishment, access, proper connecting techniques, and work practices required by R 408.42629(1) and (2) and R 408.42646.

- (c) Specific training on personnel hoisting as prescribed in Construction Safety Standard Part 28. "Personnel Hoisting in Steel Erection," being R 408.42801 to R 408.42809.

(3) Where CDZs are being used, an employer shall assure that each employee has been provided training in both of the following areas:

- (a) The nature of the hazards associated with work within a controlled decking zone.
- (b) The establishment, access, proper installation techniques, and work practices required by R 408.42620, R 408.42622, R 408.42640, and R 408.42648.

R 408.42656 Rescinded.**NON-MANDATORY APPENDIXES****APPENDIX A - SITE SPECIFIC ERECTION PLAN****GUIDELINES FOR ESTABLISHING THE COMPONENTS OF A SITE-SPECIFIC ERECTION PLAN.****NON-MANDATORY GUIDELINES FOR COMPLYING WITH R 408.42608(5).**

(a) General. This appendix serves as a guideline to assist employers who elect to develop a site-specific erection plan in accordance with R 408.42608(5) with alternate means and methods to provide employee protection in accordance with R 408.42608(5), R 408.42609(3), R 408.42634(4), and R 408.42638(4) of Construction Safety Standard, Part 26 "Steel Erection."

(b) Development of a site-specific erection plan. Pre-construction conference(s) and site inspection(s) are held between the erector and the controlling contractor, and others such as the project engineer and fabricator before the start of steel erection. The purpose of such conference(s) is to develop and review the site-specific erection plan that will meet the requirements of this section.

(c) Components of a site-specific erection plan. In developing a site-specific erection plan, a steel erector considers the following elements:

- (1) The sequence of erection activity, developed in coordination with the controlling contractor, that includes the following:
 - (i) Material deliveries;
 - (ii) Material staging and storage; and
 - (iii) Coordination with other trades and construction activities.
- (2) A description of the crane and derrick selection and placement procedures, including the following:
 - (i) Site preparation;
 - (ii) Path for overhead loads; and
 - (iii) Critical lifts, including rigging supplies and equipment.
- (3) A description of steel erection activities and procedures, including the following:
 - (i) Stability considerations requiring temporary bracing and guying;

- (ii) Erection bridging terminus point;
 - (iii) Anchor rod (anchor bolt) notifications regarding repair, replacement and modifications;
 - (iv) Columns and beams (including joists and purlins);
 - (v) Connections;
 - (vi) Decking; and
 - (vii) Ornamental and miscellaneous iron.
- (4) A description of the fall protection procedures that will be used to comply with R 408.42645, R 408.42646, R 408.42648, and R 408.42651 of Construction Safety Standard, Part 26 "Steel Erection."
 - (5) A description of the procedures that will be used to comply with R 408.42644 of Construction Safety Standard, Part 26 "Steel Erection."
 - (6) A description of the special procedures required for hazardous non-routine tasks.
 - (7) A certification for each employee who has received training for performing steel erection operations as required by R 408.42653 and R 408.42655 of Construction Safety Standard, Part 26 "Steel Erection."
 - (8) A list of the qualified and competent persons.
 - (9) A description of the procedures that will be utilized in the event of rescue or emergency response.
- (d) Other plan information. The plan:**
- (1) Includes the identification of the site and project; and
 - (2) Is signed and dated by the qualified person(s) responsible for its preparation and modification.

APPENDIX B - SLIP RESISTANCE OF SURFACES**ACCEPTABLE TEST METHODS FOR TESTING SLIP-RESISTANCE OF WALKING/WORKING SURFACES.****NON-MANDATORY GUIDELINES FOR COMPLYING WITH R 408.42616(3).**

The following references provide acceptable test methods for complying with the requirements of R 408.42616(3) of Construction Safety Standard, Part 26 "Steel Erection."

Standard Test Method for Using a Portable Inclineable Articulated Strut Slip Tester (PIAST) (ASTM F1677-96)

Standard Test Method for Using a Variable Incidence Tribometer (VIT) (ASTM F1679-96)

APPENDIX C - BRIDGING TERMINUS POINTS

ILLUSTRATIONS OF BRIDGING TERMINUS POINTS.

NON-MANDATORY GUIDELINES FOR COMPLYING WITH R 408.42634(11) AND R 408.42636(9)

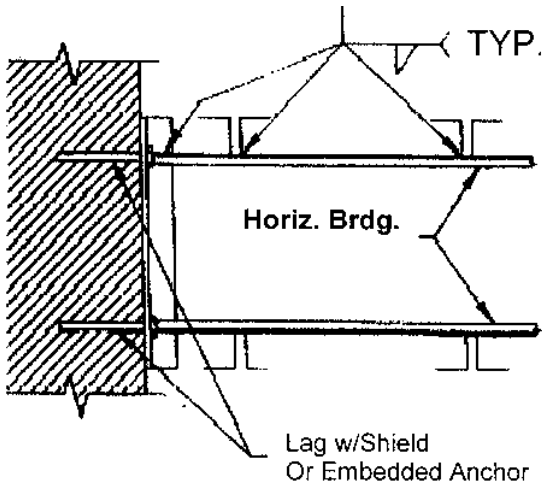

**Horizontal Bridging
Terminus at Wall**

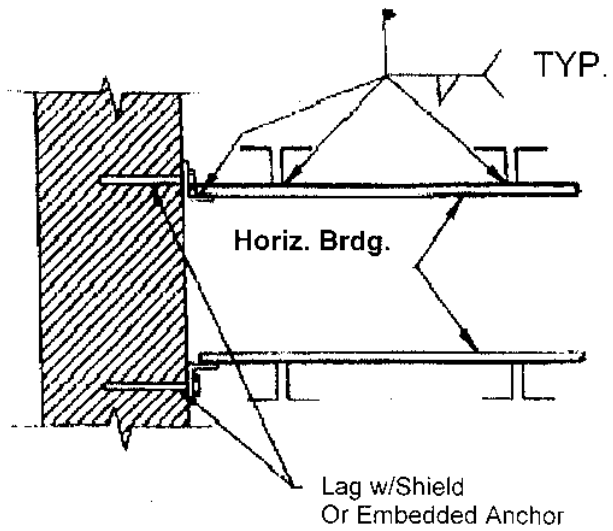

**Horizontal Bridging
Terminus at Wall**

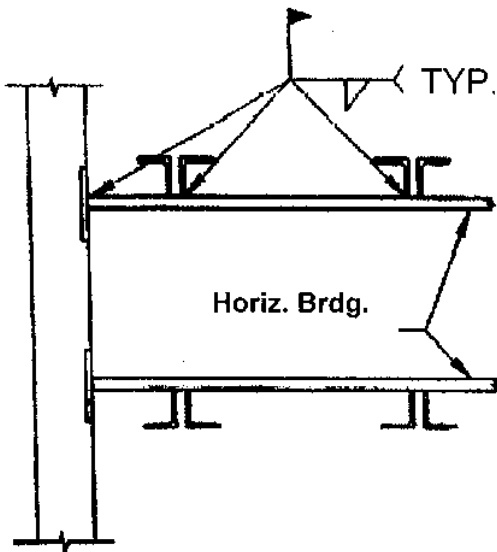

**Horizontal Bridging
Terminus at Panel Wall**

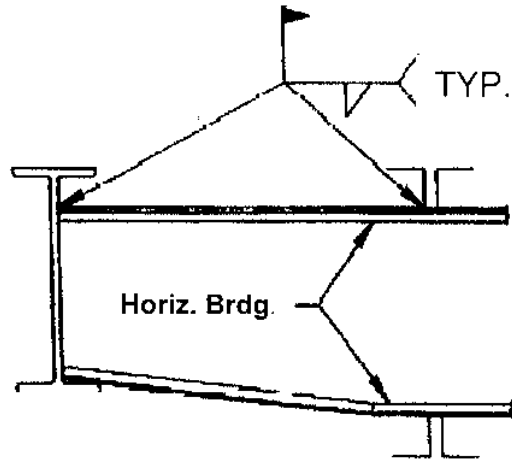

**Horizontal Bridging
Terminus at Structural
Shape**

APPENDIX C - Continued

ILLUSTRATIONS OF BRIDGING TERMINUS POINTS.

NON-MANDATORY GUIDELINES FOR COMPLYING WITH R 408.42634(11) AND R 408.42636(9)

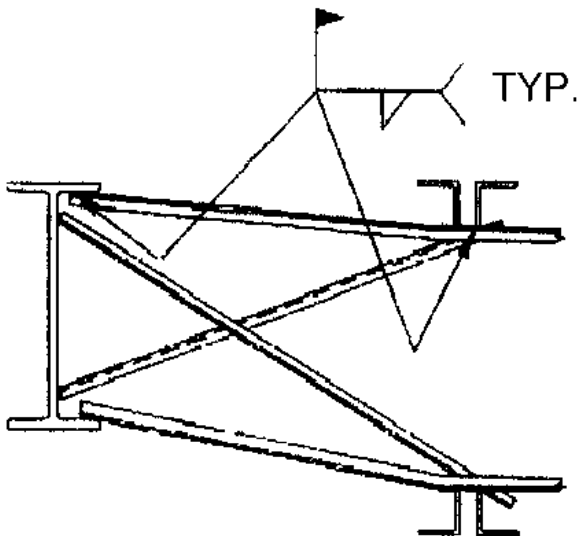

**Horizontal Bridging
Terminus at Structural
Shape with Optional
“X-Bridging”**

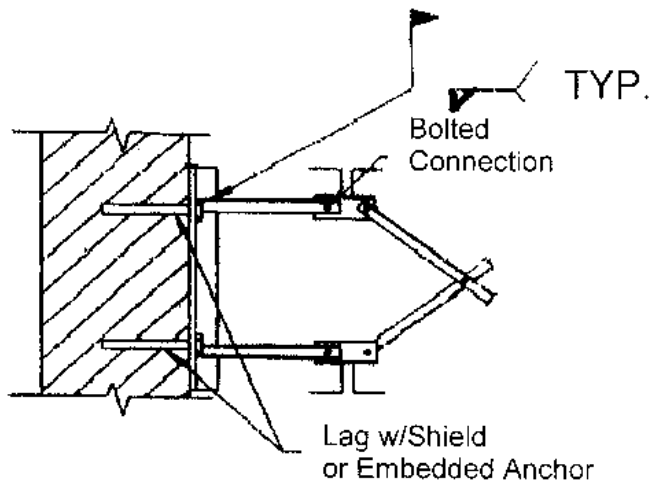

**Bolted Diagonal Bridging
Terminus at Wall**

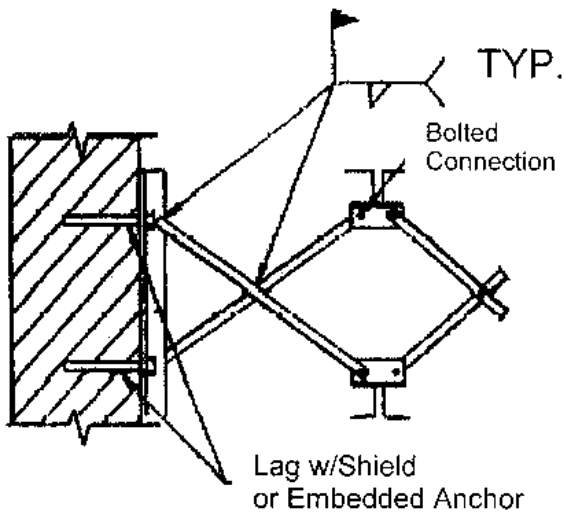

**Bolted Diagonal Bridging
Terminus at Wall**

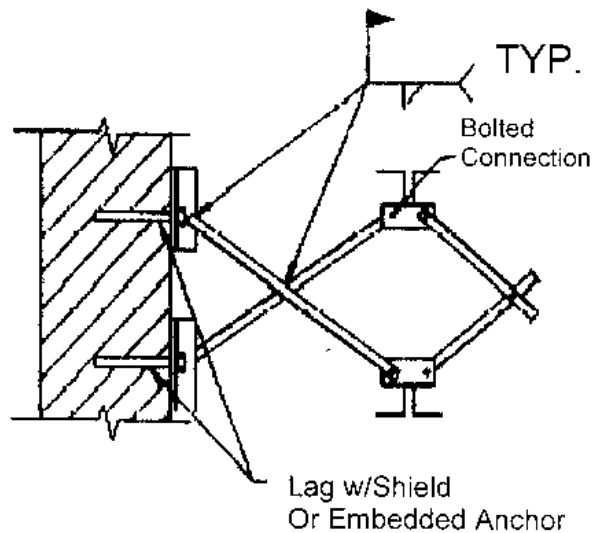

**Bolted Diagonal Bridging
Terminus at Wall**

APPENDIX C - Continued

ILLUSTRATIONS OF BRIDGING TERMINUS POINTS.

NON-MANDATORY GUIDELINES FOR COMPLYING WITH R 408.42634(11) AND R 408.42636(9)

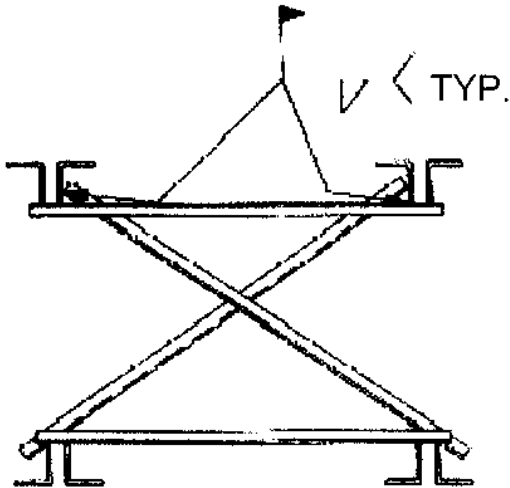

**Joists Pair Bridging
Terminus Point**

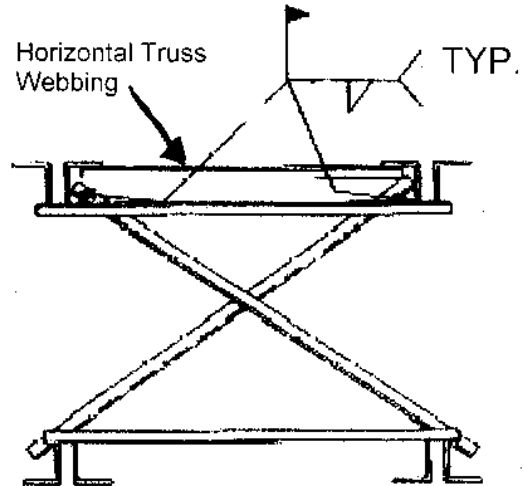

**Joists Pair Bridging
Terminus Point
with Horizontal Truss**

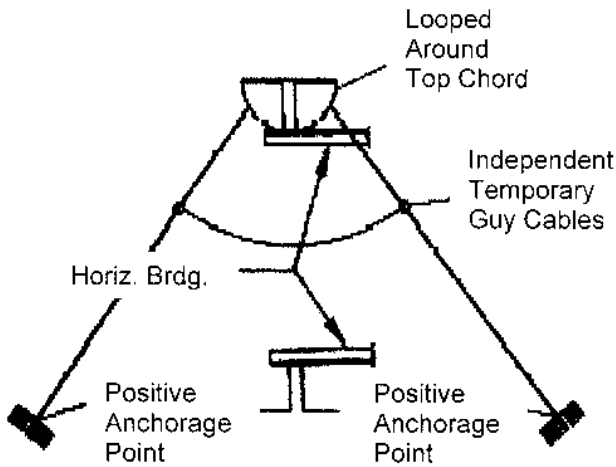

**Horizontal Bridging
Terminus Point
Secured by
Temporary Guy Cables**

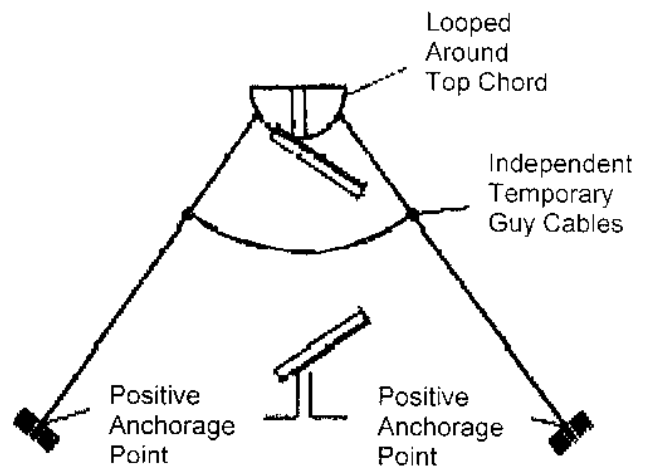

**Diagonal Bridging
Terminus Point
Secured by
Temporary Guy Cables**

APPENDIX D - CONTROLLED DECKING ZONES**ILLUSTRATION OF THE USE OF CONTROL LINES TO DEMARCATÉ CONTROLLED DECKING ZONES (CDZ'S).****NON-MANDATORY GUIDELINES FOR COMPLYING WITH R 408.42648(3)(C)."**

(1) When used to control access to areas where leading edge and initial securement of metal deck and other operations connected with leading edge work are taking place, the controlled decking zone (CDZ) is defined by a control line or by any other means that restricts access.

- (i) A control line for a CDZ is erected not less than 6 feet (1.8 m) nor more than 90 feet (27.4 m) from the leading edge.
 - (ii) Control lines extend along the entire length of the unprotected or leading edge and are approximately parallel to the unprotected or leading edge.
 - (iii) Control lines are connected on each side to a guardrail system, wall, stanchion or other suitable anchorage.
- (2) Control lines consist of ropes, wires, tapes, or equivalent materials, and supporting stanchions as follows:
- (i) Each line is rigged and supported in such a way that its lowest point (including sag) is not less than 39 inches (1.0 m) from the walking/working surface and its highest point is not more than 45 inches (1.3 m) from the walking/working surface.
 - (ii) Each line has a minimum breaking strength of 200 pounds (90.8 kg).

APPENDIX E - TRAINING.**NON-MANDATORY GUIDELINES FOR COMPLYING WITH R 408.42653 AND R 408.42655**

The training requirements of R 408.42653 and R 408.42655 of Construction Safety Standard, Part 26 "Steel Erection," will be deemed to have been met if employees have completed a training course on steel erection, including instruction in the provisions of this standard, that has been approved by the U.S. Department of Labor Bureau of Apprenticeship.

APPENDIX F - PERIMETER COLUMNS.**NON-MANDATORY GUIDELINES FOR COMPLYING WITH R 408.42628(5). TO PROTECT THE UNPROTECTED SIDE OR EDGE OF A WALKING/WORKING SURFACE.**

In multi-story structures, when holes in the column web are used for perimeter safety cables, the column splice must be placed sufficiently high so as not to interfere with any attachments to the column necessary for the column splice. Column splices are recommended to be placed at every other or fourth levels as design allows. Column splices at third levels are detrimental to the erection process and should be avoided if possible.

APPENDIX G - FALL PROTECTION**CONSTRUCTION SAFETY STANDARD PART 45 "FALL PROTECTION," BEING R 408.44501(4) FALL PROTECTION SYSTEMS CRITERIA AND PRACTICES.**

(b) "Guardrail systems." Guardrail systems and their use shall comply with the following provisions:

(1) Top edge height of top rails, or equivalent guardrail system members, shall be 42 inches (1.1 m) plus or minus 3 inches (8 cm) above the walking/working level. When conditions warrant, the height of the top edge may exceed the 45-inch height, provided the guardrail system meets all other criteria of Construction Safety Standard Part 45 "Fall Protection," being R 408.44501 et seq. of the Michigan Administrative Code.

Note: When employees are using stilts, the top edge height of the top rail, or equivalent member, shall be increased an amount equal to the height of the stilts.

(2) Midrails, screens, mesh, intermediate vertical members, or equivalent intermediate structural members shall be installed between the top edge of the guardrail system and the walking/working surface when there is no wall or parapet wall at least 21 inches (53 cm) high.

- (i) Midrails, when used, shall be installed at a height midway between the top edge of the guardrail system and the walking/working level.
- (ii) Screens and mesh, when used, shall extend from the top rail to the walking/working level and along the entire opening between top rail supports.
- (iii) Intermediate members (such as balusters), when used between posts, shall be not more than 19 inches (48 cm) apart.
- (iv) Other structural members (such as additional midrails and architectural panels) shall be installed such that there are no openings in the guardrail system that are more than 19 inches (.5 m) wide.

(3) Guardrail systems shall be capable of withstanding, without failure, a force of at least 200 pounds (890 n) applied within 2 inches (5.1 cm) of the top edge, in any outward or downward direction, at any point along the top edge.

(4) When the 200 pound (890 N) test load specified in Construction Safety Standard Part 45 "Fall Protection," being R 408.44501 et seq. of the Michigan Administrative Code is applied in a downward direction, the top edge of the guardrail shall not deflect to a height less than 39 inches (1.0 m) above the walking/working level. Guardrail system components selected and constructed in accordance with Construction Safety Standard Part 45 "Fall Protection," being R 408.44501 et seq. of the Michigan Administrative Code will be deemed to meet this requirement.

(5) Midrails, screens, mesh, intermediate vertical members, solid panels, and equivalent structural members shall be capable of withstanding, without failure, a force of at least 150 pounds (666 N) applied in any downward or outward direction at any point along the midrail or other member.

(6) Guardrail systems shall be so surfaced as to prevent injury to an employee from punctures or lacerations, and to prevent snagging of clothing.

(7) The ends of all top rails and midrails shall not overhang the terminal posts, except where such overhang does not constitute a projection hazard.

(8) Steel banding and plastic banding shall not be used as top rails or midrails.

(9) Top rails and midrails shall be at least one-quarter inch (0.6 cm) nominal diameter or thickness to prevent cuts and lacerations. If wire rope is used for top rails, it shall be flagged at not more than 6-foot intervals with high-visibility material.

(10) When guardrail systems are used at hoisting areas, a chain, gate or removable guardrail section shall be placed across the access opening between guardrail sections when hoisting operations are not taking place.

(11) When guardrail systems are used at holes, they shall be erected on all unprotected sides or edges of the hole.

(12) When guardrail systems are used around holes used for the passage of materials, the hole shall have not more than two sides provided with removable guardrail sections to allow the passage of materials. When the hole is not in use, it shall be closed over with a cover, or a guardrail system shall be provided along all unprotected sides or edges.

(13) When guardrail systems are used around holes which are used as points of access (such as ladderways), they shall be provided with a gate, or be so offset that a person cannot walk directly into the hole.

(14) Guardrail systems used on ramps and runways shall be erected along each unprotected side or edge.

(15) Manila, plastic or synthetic rope being used for top rails or midrails shall be inspected as frequently as necessary to ensure that it continues to meet the strength requirements of Construction Safety Standard Part 45 "Fall Protection," being R 408.44501 et seq. of the Michigan Administrative Code.

(c) "Safety net systems." Safety net systems and their use shall comply with the following provisions:

(1) Safety nets shall be installed as close as practicable under the walking/working surface on which employees are working, but in no case more than 30 feet (9.1 m) below such level. When nets are used on bridges, the potential fall area from the walking/working surface to the net shall be unobstructed.

(2) Safety nets shall extend outward from the outermost projection of the work surface as follows:

VERTICAL DISTANCE FROM WORKING LEVEL TO HORIZONTAL PLANE OF NET	MINIMUM REQUIRED HORIZONTAL DISTANCE OF OUTER EDGE OF NET FROM THE EDGE OF THE WORKING SURFACE
Up to 5 feet	8 feet
More than 5 feet up to 10 feet	10 feet
More than 10 feet	13 feet

(3) Safety nets shall be installed with sufficient clearance under them to prevent contact with the surface or structures below when subjected to an impact force equal to the drop test specified in Construction Safety Standard Part 45 "Fall Protection," being R 408.44501 et seq. of the Michigan Administrative Code.

(4) Safety nets and their installations shall be capable of absorbing an impact force equal to that produced by the drop test specified in Construction Safety Standard Part 45 "Fall Protection," being R 408.44501 et seq. of the Michigan Administrative Code.

- (i) Except as provided in Construction Safety Standard Part 45 "Fall Protection," being R 408.44501 et seq. of the Michigan Administrative Code, safety nets and safety net installations shall be drop-tested at the jobsite after initial installation and before being used as a fall protection system, whenever relocated, after major repair, and at 6-month intervals if left in one place. The drop-test shall consist of a 400 pound (180 kg) bag of sand 30 + or - 2 inches (76 + or - 5 cm) in diameter dropped into the net from the highest walking/working surface at which employees are exposed to fall hazards, but not from less than 42 inches (1.1 m) above that level.

- (ii) When the employer can demonstrate that it is unreasonable to perform the drop-test required by Construction Safety Standard Part 45 "Fall Protection," being R 408.44501 et seq. of the Michigan Administrative Code, the employer (or a designated competent person) shall certify that the net and net installation is in compliance with the provisions of Construction Safety Standard Part 45 "Fall Protection," being R 408.44501 et seq. of the Michigan Administrative Code, by preparing a certification record prior to the net being used as a fall protection system. The certification record must include an identification of the net and net installation for which the certification record is being prepared; the date that it was determined that the identified net and net installation were in compliance with Construction Safety Standard Part 45 "Fall Protection," being R 408.44501 et seq. of the Michigan Administrative Code, and the signature of the person making the determination and certification. The most recent certification record for each net and net installation shall be available at the jobsite for inspection.

(5) Defective nets shall not be used. Safety nets shall be inspected at least once a week for wear, damage, and other deterioration. Defective components shall be removed from service. Safety nets shall also be inspected after any occurrence which could affect the integrity of the safety net system.

(6) Materials, scrap pieces, equipment, and tools which have fallen into the safety net shall be removed as soon as possible from the net and at least before the next work shift.

(7) The maximum size of each safety net mesh opening shall not exceed 36 square inches (230 cm) nor be longer than 6 inches (15 cm) on any side, and the opening, measured center-to-center of mesh ropes or webbing, shall not be longer than 6 inches (15 cm). All mesh crossings shall be secured to prevent enlargement of the mesh opening.

(8) Each safety net (or section of it) shall have a border rope for webbing with a minimum breaking strength of 5,000 pounds (22.2 kN).

(9) Connections between safety net panels shall be as strong as integral net components and shall be spaced not more than 6 inches (15 cm) apart.

(d) "Personal fall arrest systems." Personal fall arrest systems and their use shall comply with the provisions set forth below. Effective January 1, 1998, body belts are not acceptable as part of a personal fall arrest system.

Note: The use of a body belt in a positioning device system is acceptable and is regulated under Construction Safety Standard Part 45 "Fall Protection," being R 408.44501 et seq. of the Michigan Administrative Code.

- (1) Connectors shall be drop forged, pressed or formed steel, or made of equivalent materials.

(2) Connectors shall have a corrosion-resistant finish, and all surfaces and edges shall be smooth to prevent damage to interfacing parts of the system.

(3) Dee-rings and snaphooks shall have a minimum tensile strength of 5,000 pounds (22.2 kN).

(4) Dee-rings and snaphooks shall be proof-tested to a minimum tensile load of 3,600 pounds (16 nN) without cracking, breaking, or taking permanent deformation.

(5) Snaphooks shall be sized to be compatible with the member to which they are connected to prevent unintentional disengagement of the snaphook by depression of the snaphook keeper by the connected member, or shall be a locking type snaphook designed and used to prevent disengagement of the snaphook by the contact of the snaphook keeper by the connected member. Effective January 1, 1998, only locking type snaphooks shall be used.

(6) Unless the snaphook is a locking type and designed for the following connections, snaphooks shall not be engaged:

- (i) Directly to webbing, rope or wire rope;
- (ii) To each other;
- (iii) To a dee-ring to which another snaphook or other connector is attached;
- (iv) To a horizontal lifeline; or
- (v) To any object which is incompatibly shaped or dimensioned in relation to the snaphook such that unintentional disengagement could occur by the connected object being able to depress the snaphook keeper and release itself.

(7) On suspended scaffolds or similar work platforms with horizontal lifelines which may become vertical lifelines, the devices used to connect to a horizontal lifeline shall be capable of locking in both directions on the lifeline.

(8) Horizontal lifelines shall be designed, installed, and used, under the supervision of a qualified person, as part of a complete personal fall arrest system, which maintains a safety factor of at least two.

(9) Lanyards and vertical lifelines shall have a minimum breaking strength of 5,000 pounds (22.2 kN).

- (10)
 - (i) Except as provided in Construction Safety Standard Part 45 "Fall Protection," being R 408.44501 et seq. of the Michigan Administrative Code, when vertical lifelines are used, each employee shall be attached to a separate lifeline.
 - (ii) During the construction of elevator shafts, two employees may be attached to the same lifeline in the hoistway, provided both employees are working atop a false car that is equipped with guardrails; the strength of the lifeline is 10,000 pounds [5,000 pounds per employee attached] (44.4 kN); and all other criteria specified in this paragraph for lifelines have been met.

(11) Lifelines shall be protected against being cut or abraded.

(12) Self-retracting lifelines and lanyards which automatically limit free fall distance to 2 feet (0.61 m) or less shall be capable of sustaining a minimum tensile load of 3,000 pounds (13.3 kN) applied to the device with the lifeline or lanyard in the fully extended position.

(13) Self-retracting lifelines and lanyards which do not limit free fall distance to 2 feet (0.61 m) or less, ripstitch lanyards, and tearing and deforming lanyards shall be capable of sustaining a minimum tensile load of 5,000 pounds (22.2 kN) applied to the device with the lifeline or lanyard in the fully extended position.

(14) Ropes and straps (webbing) used in lanyards, lifelines, and strength components of body belts and body harnesses shall be made from synthetic fibers.

(15) Anchorages used for attachment of personal fall arrest equipment shall be independent of any anchorage being used to support or suspend platforms and capable of supporting at least 5,000 pounds (22.2 kN) per employee attached, or shall be designed, installed, and used as follows:

- (i) As part of a complete personal fall arrest system which maintains a safety factor of at least two; and
 - (ii) Under the supervision of a qualified person.
- (16) Personal fall arrest systems, when stopping a fall, shall:
- (i) Limit maximum arresting force on an employee to 900 pounds (4 kN) when used with a body belt;
 - (ii) Limit maximum arresting force on an employee to 1,800 pounds (8 kN) when used with a body harness;
 - (iii) Be rigged such that an employee can neither free fall more than 6 feet (1.8 m), nor contact any lower level;
 - (iv) Bring an employee to a complete stop and limit maximum deceleration distance an employee travels to 3.5 feet (1.07 m); and,
 - (v) Have sufficient strength to withstand twice the potential impact energy of an employee free falling a distance of 6 feet (1.8 m), or the free fall distance permitted by the system, whichever is less.

Note: If the personal fall arrest system meets the criteria and protocols contained in appendix C to Construction Safety Standard Part 45, "Fall Protection," being R 408.44501 et seq. of the Michigan Administrative Code and if the system is being used by an employee having a combined person and tool weight of less than 310 pounds (140 kg), the system will be considered to be in compliance with the provisions of Construction Safety Standard Part 45 "Fall Protection," being R 408.44501 et seq. of the Michigan Administrative Code. If the system is used by an employee having a combined tool and body weight of 310 pounds (140 kg) or more, then the employer must appropriately modify the criteria and protocols of the appendix to provide proper protection for such heavier weights, or the system will not be deemed to be in compliance with the requirements of Construction Safety Standard Part 45 "Fall Protection," being R 408.44501 et seq. of the Michigan Administrative Code.

(17) The attachment point of the body belt shall be located in the center of the wearer's back. The attachment point of the body harness shall be located in the center of the wearer's back near shoulder level, or above the wearer's head.

(18) Body belts, harnesses, and components shall be used only for employee protection (as part of a personal fall arrest system or positioning device system) and not to hoist materials.

(19) Personal fall arrest systems and components subjected to impact loading shall be immediately removed from service and shall not be used again for employee protection until inspected and determined by a competent person to be undamaged and suitable for reuse.

(20) The employer shall provide for prompt rescue of employees in the event of a fall or shall assure that employees are able to rescue themselves.

(21) Personal fall arrest systems shall be inspected prior to each use for wear, damage and other deterioration, and defective components shall be removed from service.

(22) Body belts shall be at least one and five-eighths (1 5/8) inches (4.1 cm) wide.

(23) Personal fall arrest systems shall not be attached to guardrail systems, nor shall they be attached to hoists except as specified in other parts of this part.

(24) When a personal fall arrest system is used at hoist areas, it shall be rigged to allow the movement of the employee only as far as the edge of the walking/working surface.

(e) "Positioning device systems." Positioning device systems and their use shall conform to the following provisions:

(1) Positioning devices shall be rigged such that an employee cannot free fall more than 2 feet (.9 m).

(2) Positioning devices shall be secured to an anchorage capable of supporting at least twice the potential impact load of an employee's fall or 3,000 pounds (13.3 kN), whichever is greater.

(3) Connectors shall be drop forged, pressed or formed steel, or made of equivalent materials.

(4) Connectors shall have a corrosion-resistant finish, and all surfaces and edges shall be smooth to prevent damage to interfacing parts of this system.

(5) Connecting assemblies shall have a minimum tensile strength of 5,000 pounds (22.2 kN).

(6) Dee-rings and snaphooks shall be proof-tested to a minimum tensile load of 3,600 pounds (16 kN) without cracking, breaking, or taking permanent deformation.

(7) Snaphooks shall be sized to be compatible with the member to which they are connected to prevent unintentional disengagement of the snaphook by depression of the snaphook keeper by the connected member, or shall be a locking type snaphook designed and used to prevent disengagement of the snaphook by the contact of the snaphook keeper by the connected member. As of January 1, 1998, only locking type snaphooks shall be used.

(8) Unless the snaphook is a locking type and designed for the following connections, snaphooks shall not be engaged:

- (i) Directly to webbing, rope or wire rope;
- (ii) To each other;
- (iii) To a dee-ring to which another snaphook or other connector is attached;
- (iv) To a horizontal lifeline; or to depress the snaphook keeper and release itself.
- (v) To any object which is incompatibly shaped or dimensioned in relation to the snaphook such that unintentional disengagement could occur by the connected object being able to depress the snaphook keeper and release itself.

(9) Positioning device systems shall be inspected prior to each use for wear, damage, and other deterioration, and defective components shall be removed from service.

(10) Body belts, harnesses, and components shall be used only for employee protection (as part of a personal fall arrest system or positioning device system) and not to hoist materials.

APPENDIX H - DOUBLE CONNECTIONS.

ILLUSTRATION OF A CLIPPED END CONNECTION AND A STAGGERED CONNECTION:

NON-MANDATORY GUIDELINES FOR COMPLYING WITH R 408.42629.

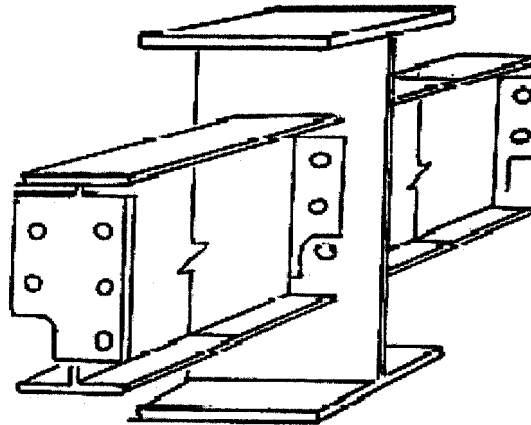

Clipped end connections are connection material on the end of a structural member which has a notch at the bottom and/or top to allow the bolt(s) of the first member placed on the opposite side of the central member to remain in place. The notch(es) fits around the nut or bolt head of the opposing member to allow the second member to be bolted up without removing the bolt(s) holding the first member.

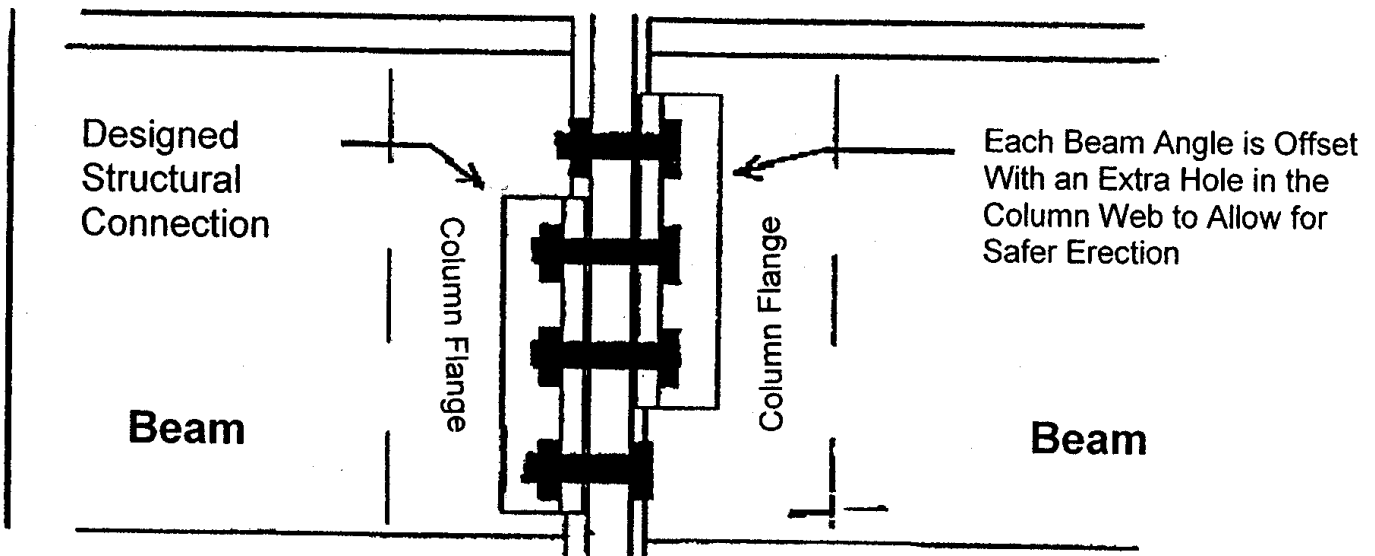
APPENDIX H - Continued**DOUBLE CONNECTIONS.**

Staggered connections are connection material on a structural member in which all of the bolt holes in the common member web are not shared by the two incoming members in the final connection. The extra hole in the column web allows the erector to maintain at least a one bolt connection at all times while making the double connection.



Michigan Occupational Safety and Health Administration
 PO Box 30643
 Lansing, Michigan 48909-8143
 Ph: 517.322.1814
 Fx: 517.322.1775

The Department of Labor & Economic Growth will not discriminate against any individual or group because of race, sex, religion, age, national origin, color, marital status, disability, or political beliefs. If you need assistance with reading, writing, hearing, etc., under the Americans with Disabilities Act, you may make your needs known to this agency.