

PDHExpress.com



Trench Collapse



1

**Professional Development Hours (PDH) or
Continuing Education Hours (CE)
Online PDH or CE course**

FDA, Inc.

The Project

The project was the I-95 Miami rehabilitation project in Miami, Florida. Archer Western Contractors, Ltd. (Archer Western) was the contractor of the project. The project included the removal and replacement of concrete pavement within the established project limits, such as replacement of all asphalt shoulder pavement with full depth concrete shoulder pavement. The project also included drainage modifications and new concrete barrier walls in the center median of the I-95, see Figures 1 and 2.

After Archer Western installed the buried drainage pipe involved in the incident, video evidence from the pipeline video inspection indicated that the pipe was either damaged during construction or mis-installed. Therefore, Archer Western decided to open a trench to repair/replace the pipe, see Figure 3, and had its employees to hand-dig the trench along the concrete barrier wall. The trench was approximately three and one-half feet deep, approximately 2 feet 10 inches wide and more than one hundred and thirty feet long. The concrete barrier wall involved in the incident was approximately 121 feet long, see Figure 4.

The Incident

On February 4, 2018, around 3:00 a.m., two employees of Archer Western were inside the trench working on the pipe. The entire concrete barrier wall, approximately 121 feet long, collapsed into the trench killing the two employees who were in the trench.

Analysis and Discussion

The trench cross section, shown in Figure 3, is based on the observations and measurements obtained from our field visit on February 6, 2018. The concrete barrier wall sat directly on the utility trench, which was backfilled with flowable fill. Other than the subgrade soil underneath, the concrete barrier wall was not supported by or secured to any other structures, such as an inlet or pavement shoulder, see Figures 4 to 6.

The loads imposed on the subgrade soil from the concrete barrier wall was not limited to the immediate area of the wall, but also extended some distance away from the wall. This distance can be estimated as being equal to the depth of the excavation. Thus, a critical plane is formed sloping up from the bottom of the excavation toward the wall at an angle of 45 degrees, see Figure 3. Since the footing of the concrete barrier wall remained completely above the critical plane, according to the discussions in the preamble to OSHA's excavation standards (at 54 Federal Register 45924, October 31, 1989), the stability of the concrete barrier wall was endangered by the excavation operations. Therefore, per OSHA standard CFR 1926.651(i)(1) support systems should have been provided to ensure stability of the concrete barrier wall to protect employees working the trench.

During our site visit, the excavated soil was classified as OSHA Type C soil according to the site conditions and natural characteristics of the earth deposits, see Figures 5 and 6. Based on the OSHA laboratory test (see Appendix A), the sample of earth deposits collected at the incident site was further classified as granular sand with no cohesion, corresponding to OSHA Type C soil.

The soil sample contained 91.7% sand and gravel. At the incident site, it was also observed that large clumps of excavated spoil broke into small pieces without difficulty. Besides, approximately 0.1 inches of rain fell within

24 hours of the incident (see Appendix B for national climatic data). These facts confirmed that the subgrade soil at the incident site was not able to sustain the concrete barrier wall when the collapse occurred.

Conclusions

Based upon the above, we conclude that:

- 1) The cause of the failure was the instability of the concrete barrier wall. The instability of the concrete barrier wall was caused by the trench excavation operations.
- 2) No support systems such as shoring, bracing, or underpinning were provided by Archer Western to ensure the safety of employees and the stability of the concrete barrier wall, prior to, during and after the trench was opened.
- 3) Archer Western violated the OSHA standard CFR 1926.651(i)(1) by not providing a support system, such as shoring, bracing, or underpinning to ensure stability of the concrete barrier wall for the protection of the employees.
- 4) Archer Western violated the OSHA standard CFR 1926.651(k)(1) by not conducting any inspection of the excavation and the adjacent areas by a competent person prior to the start of the work or as needed throughout the shift, on or prior to 02/04/2018.

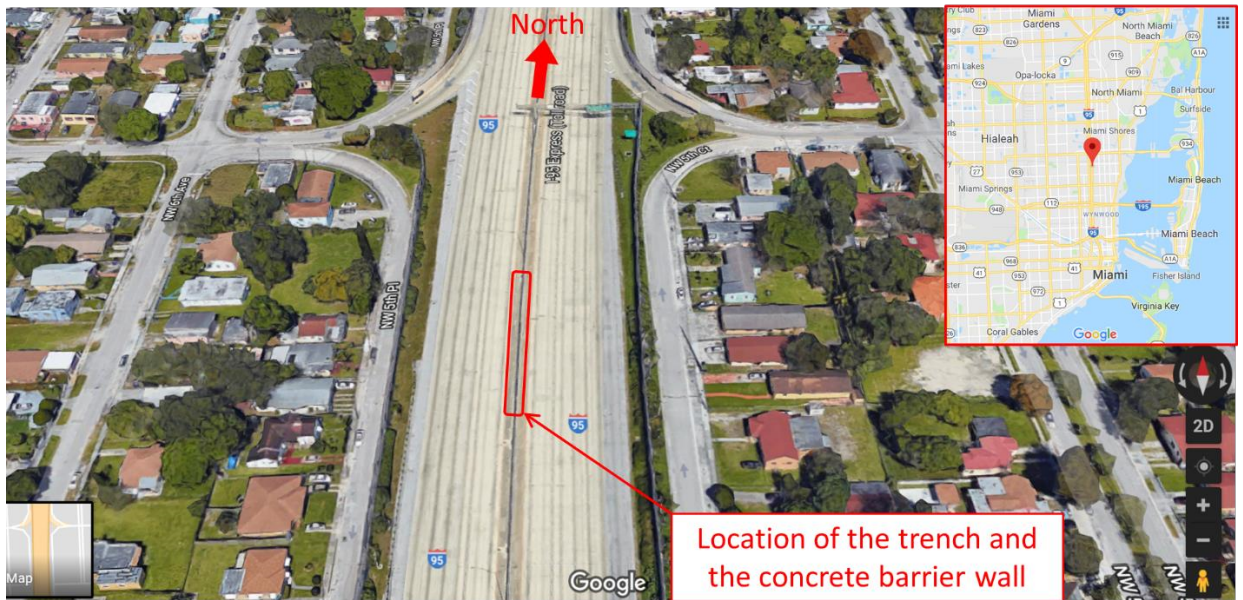

Figure 1 Project site (courtesy of Google.com)

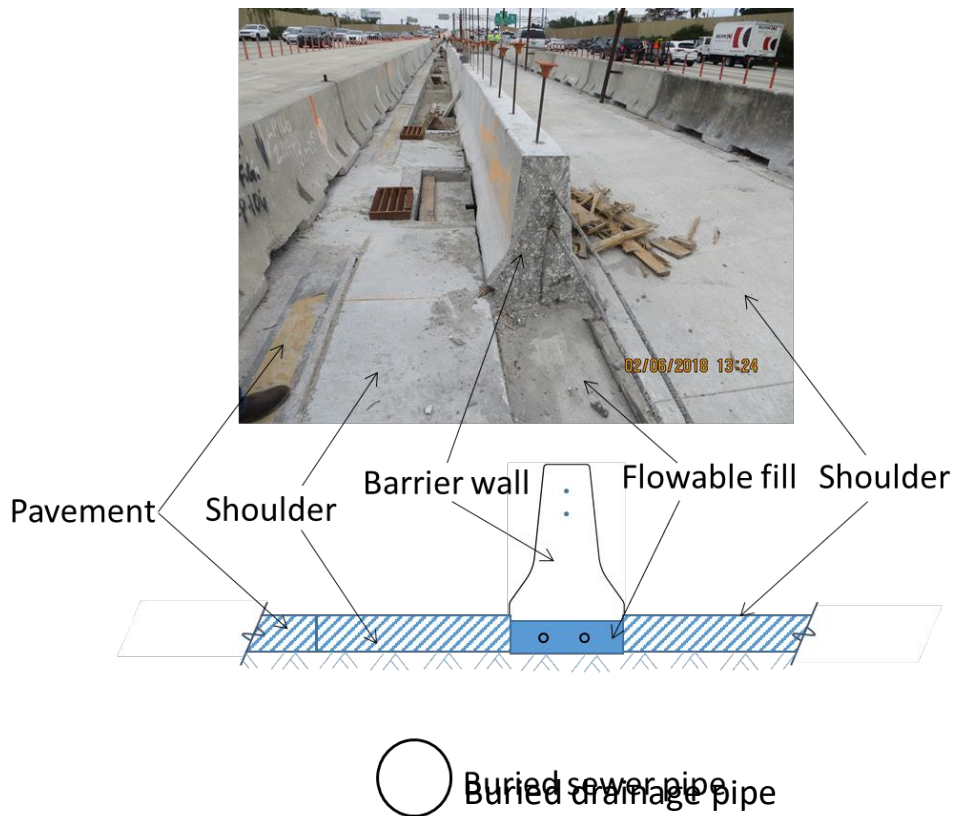

Figure 2 Typical section before excavation – looking north

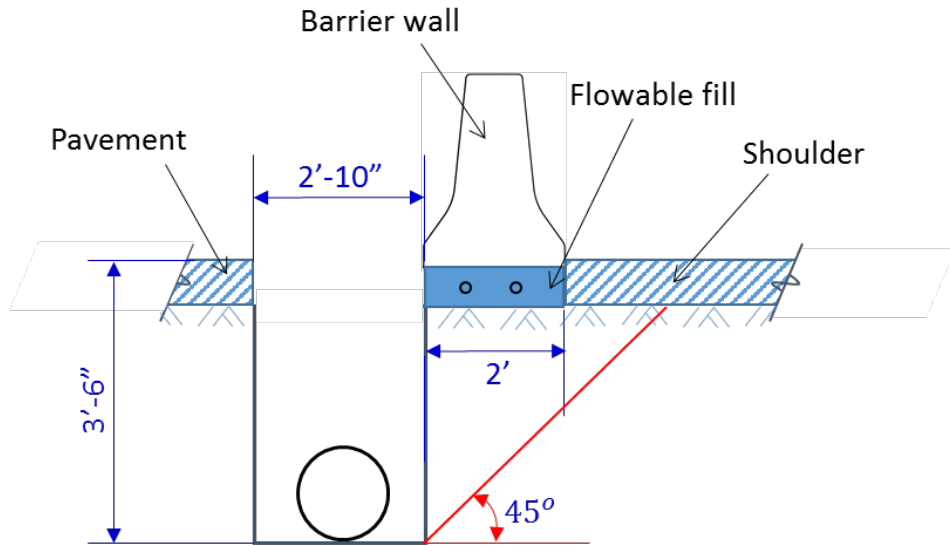

Figure 3 Typical section of the excavation prior to the collapse – looking north

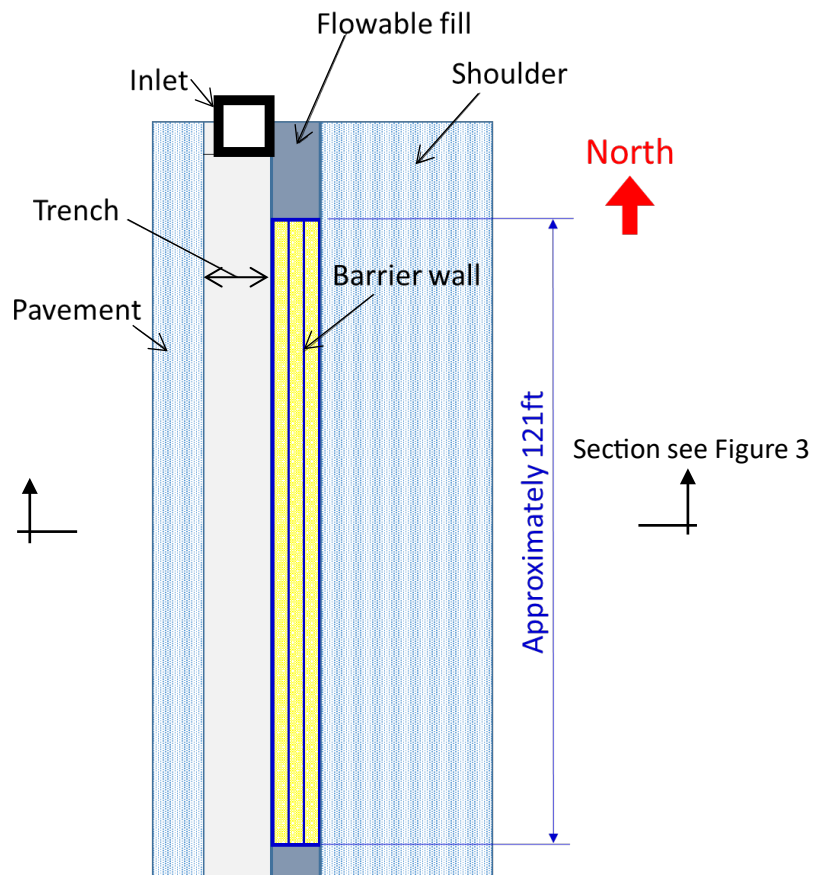

Figure 4 Plan view of the incident site



Figure 5 Scene of incident – looking south (North end of the barrier wall)



Figure 6 South end of the concrete barrier wall

1. Reporting ID 418800	2. Inspection Number 1293032	3. Sampling Number 301406
4. Establishment Name Archer Western Construction, LLC		
5. CSHO ID J9763	6. Sampling Date 06 FEB 2018	7. Shipping Date 07 FEB 2018
9. Job Title Not applicable		10. Occupational Code
11. Number Exposed		
12. Frequency of Exposure		

Exposure Summary

14. Substance Code	15. Rqstd	16. Smpl Type	17. Exp Type	18. Exp Level	19. Units	20. PEL	21. Adj	22. Severity	23. Citation information						
									No Cit	FTA	Over Exp	Eng	PPE	Trng	Med

TWA calculated on actual time sampled
The I. H. is free to make changes on the Form 91B and submit them directly to IMIS

26. Analyst's Comments (Analytical Method) OSHA ID-194

27. Chain of Custody	Init.	Date
a. Seals Intact		Y
b. Rec'd In Lab	KAS	20 MAR 2018
c. Rec'd by Anal.	DJH	26 MAR 2018
d. Anal. Completed	DJH	28 MAR 2018
e. Calc. Checked	SEA	28 MAR 2018
f. Supr. OK'd	DJH	28 MAR 2018

S15809 S777 Classification of S15809:

Textural: Sand
Structural: Granular
Type: C

This sample was classified as Type C because it contained 91.7% sand & gravel.

28 Submission number HS-32

29 Lab Sample No. S15809 (Minutes/Type) B

30. Analyte 31. Analysis Results/ 32. Sample included in calculations of

S777 Soil
N

Because the results for air samples are used in further calculations, the number of figures reported in section 31 may not reflect the actual precision of the analysis. Calculated confidence limits (UCL & LCL) should be rounded to no more than three significant figures. The precision of analysis for wipe samples and for bulk material samples justify rounding results to no more than two significant figures.

The Sampling and Analytical Error (SAE) is the current value for the specific chemical(s) and should be used for the calculations. Blank values are reported for reference only. Appropriate blank corrections have been applied to the samples by the Salt Lake Technical Center. Blank results are less than the reporting limit(s) unless otherwise noted.

33. Analyte Code SAE Value
S777

L MILLIGRAMS PER LITER (URINE)	D MICROGRAMS PER DECILITER (BLOOD)
C PICO CURIES PER LITER (RADON GAS)	P PARTS PER MILLION
F FIBERS PER CUBIC CENTIMETER	X MICROGRAMS
M MILLIGRAMS PER CUBIC METER	% PERCENT
Y MILLIGRAMS	E FIBERS PER MM2
N NONE	G MILLION PARTICLES PER CUBIC FOOT (MPPCF)

Sampling Number: 301406

BM/S Bar Meters per Second

mcg/l Micrograms per Cubic Meter

Bulk samples are analyzed to provide an estimate of the composition of the material submitted. The results reported should be considered semi-quantitative only. Reporting limit for quartz in bulk samples is 1%

Analyte codes are chosen by the laboratory. The I. H. should review them for applicability. if there are any questions call the laboratory for appropriate analyte codes (ie. ICP uses fume analyte codes when the IH may have sampled for dust).

We value your comments regarding the customer support provided by the Salt Lake Technical Center Industrial Hygiene Chemistry Laboratory. You may leave comments (either positive or negative) with us at feedback.SLTC.IHC@dol.gov.

For questions regarding a specific case, please contact the Chromatography Group Manager, or the Spectroscopy and Physical Measurements Group Manager listed at <http://intranet.osha.gov/gts/LAP/sltc.html>.

Sampling Number: 301406

Permissible Exposure Limit Summary

Office ID 418800	Inspection Number 1293032	Sampled Establishment Archer Western Construction, LLC	Sampling Number 301406				
Analyte Code	Req	Sample Type	Exposure Type	Exposure	Unit	PEL	PEL Severity

The following potentially applicable occupational exposure limits (OELs) are provided for reference only. OELs are not to be cited as OSHA standards. OELs referenced below can be a useful part of identifying the existence of a hazardous condition, but may not be sufficient alone to provide evidence of either hazard recognition or potential means of abatement.

Analyte Code	Req	Sample Type	Exposure Type	Exposure	Unit	REL	REL Severity
Analyte Code	Req	Sample Type	Exposure Type	Exposure	Unit	TLV	TLV Severity

Local Climatological Data
Daily Summary
February 2018
 Generated on 05/30/2018

Date	Temperature (F)							Degree Days (base 65F)			Sun (LST)		Weather		Precipitation (in)			Pressure (inHg)		Wind		Maximum Wind Speed = MPH		
	Max	Min	Avg	Dep	ARH	ADP	AWB	Heat	Cool	Rise	Set	Weather Type	TLC	Snow Depth	Avg Sfc	Avg SL	Peak Speed	Peak Dir	Sust. Speed	Sust. Dir	Peak Speed	Sust. Speed	Direction = Degrees	
1	2	3	4	5	6	7	8	9	10	11	12	13	14	15	16	17	18	19	20	21	22	23		
01	79	58*	68	-0.9				0	3	0705	1805					30.14	6.0	20	110	16	110			
02	82	64	73	4.0				0	8	0705	1806					30.12	3.6	15	300	10	110			
03	75	67	71	1.3				0	6	0704	1808	EA:BR	0.12		30.14	8.8	25	100	21	100				
04	80	69	74	4.8				0	9	0704	1807				30.04	9.8	29	160	18	150				
05	84	70	77	7.7				0	12	0703	1808				30.06	6.2	21	080	17	080				
06	79	70	74	4.6				0	9	0703	1809				30.19	10.5	19	090	16	090				
07	83	72	78	8.5				0	13	0702	1809				30.17	10.4	28	120	21	120				
08	84	73	78	8.4				0	13	0701	1810				30.17	9.1	18	090	15	080				
09	83	72	78	8.3				0	13	0701	1811	RA:BR	0.04		30.16	11.8	25	070	20	100				
10	84	72	78	8.2				0	13	0700	1811				30.12	12.8	29	120	21	110				
11	85	75	80	10.1				0	15	0700	1812				30.11	13.2	30	120	23	120				
12	84	75	80	10.0				0	15	0659	1813				30.21	11.6	27	140	20	140				
13	85	73	79	8.9				0	14	0658	1813				30.29	11.1	22	120	17	120				
14	83	72	78	7.8				0	13	0657	1814				30.29	10.2	22	110	18	120				
15	82	67	74	3.7				0	9	0657	1815				30.24	5.9	20	100	14	100				
16	83	64	74	3.6				0	9	0656	1815				30.16	4.4	20	160	13	150				
17	84	66	75	4.5				0	10	0655	1816				30.16	5.2	25	170	15	130				
18	84	70	77	6.4				0	12	0654	1817				30.17	9.0	28	090	18	120				
19	84	70	77	6.4				0	12	0654	1817	RA:BR	0.10		30.19	15.3	29	100	25	090				
20	84	73	78	7.3				0	13	0653	1818	RA			30.24	17.3	30	120	23	100				
21	83	74	78	7.2				0	13	0652	1818				30.29	16.8	37	090	25	080				
22	83	72	78	7.1				0	13	0651	1819	RA:BR	0.01		30.29	14.1	28	100	24	100				
23	82	72	77	6.0				0	12	0650	1820	RA	0.02		30.26	15.3	27	090	22	080				
24	82	71	76	4.9				0	11	0649	1820	RA			30.15	13.2	27	100	22	110				
25	82	71	78	4.9				0	11	0648	1821				30.13	9.9	26	110	16	100				
26	84	71	78	6.8				0	13	0648	1821	RA	0.02		30.12	7.1	22	110	15	250				
27	85*	68	76	4.7				0	11	0647	1822	RA	0.06		30.12	6.3	24	080	17	090				
28	81	70	76	4.6				0	11	0646	1822				30.06	9.8	20	100	15	100				
	82.6	70.0	76.3												30.17	30.21	10.1							
	4.5	7.7	6.1																					
Monthly Averages Totals												Number of days with...												
Departure from Normal (1981-2010)												-1.88												

Heating Cooling	Degree Days		Season-to-date		Temperature		Precipitation		Snow		Weather												
	Total	Monthly	Total	Departure	Max	Min	>=0.1"	>=1"	>=1"	T-Storms	Heavy Fog												
0	0	-26	81		0	<=32°	<=0°	>=0.1"	2	0													
317	146	465			0	<=32°	<=0°	>=0.1"	7	0													
Date of 5-sec to 3-sec wind equipment change												Greatest...											
2009-07-14												24-Hr...											
Maximum												Time											
Minimum												1705											
30.39												13											
30.00												04											
0.12												0.12											
03-03												Date											
Station Augmentation												Name: N/A Lat: N/A Lon: N/A Elevation: N/A Distance: N/A Elements: N/A Equipment: N/A											

